

REVISIONS					
REV	ECO	DESCRIPTION	DATE	BY	APPR
A1	--	RELEASED DRAWING	AUG-09-16	JARRY	TOMMY
A2	--	UPDATE NOTES	Jun-22-2017	Nick	TOMMY
A3	--	UPDATE CABLE OD RANGE	Aug-24-2017	Nick	TOMMY

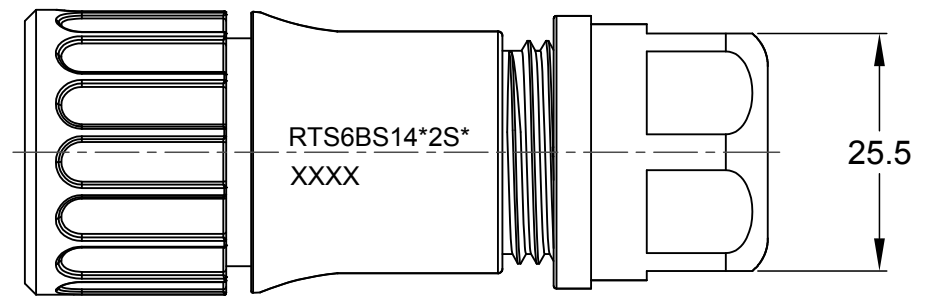
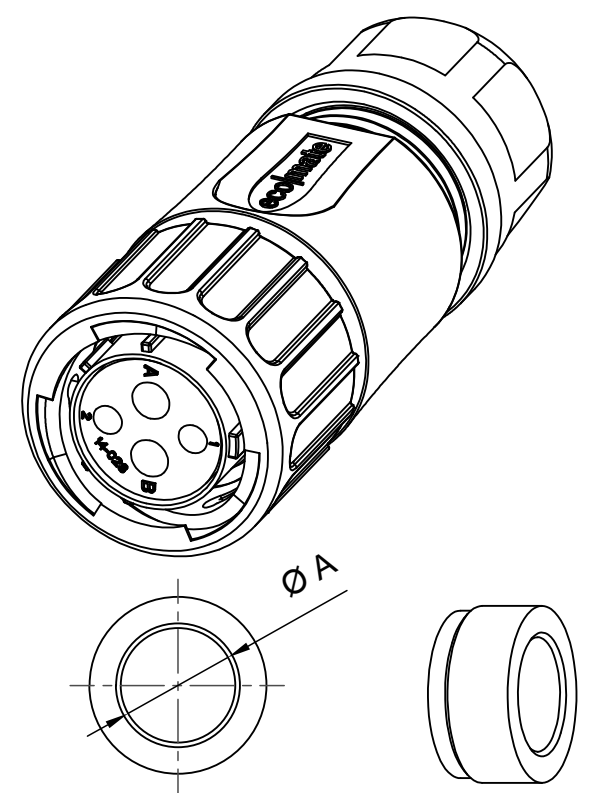
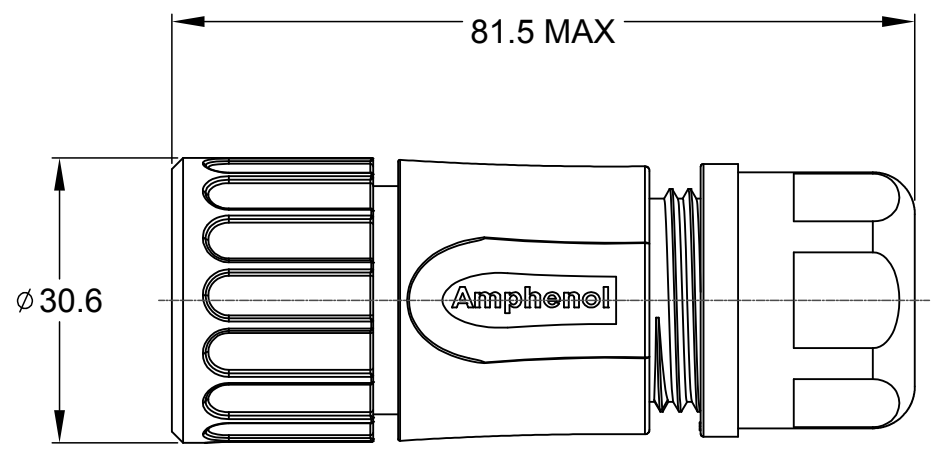
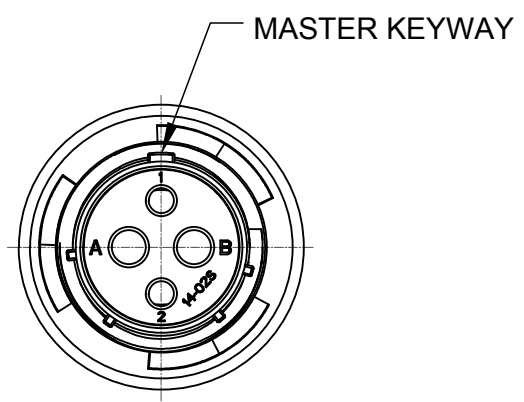

- NOTES : (UNLESS OTHERWISE SPECIFIED)
- MATERIAL :
 SHELL : THERMOPLASTIC , UL94 V-0.
 INSERT : THERMOPLASTIC , UL94 V-0.
 COUPLING NUT : THERMOPLASTIC , UL94 V-0.
 O-RING : NBR OR SILICONE RUBBER.
 WASHER : SILICONE RUBBER.
 BACK SHELL : THERMOPLASTIC , UL94 V-0.
 CLAMP NUT : THERMOPLASTIC , UL94 V-0.
 CLAMP RING : THERMOPLASTIC , UL94 V-0.
 CABLE SEAL : EPDM.
 - SPECIFICATIONS :
 2.1 RATED CURRENT : 2.5MM CONTACT @ 23A (MAX).
 16# CONTACT @ 13A (MAX). 2.2 RATED VOLTAGE :
 500V(AC/DC).
 2.3 OPERATING TEMPERATURE : SEE CHART .
 2.4 DIELECTRIC WITHSTANDING VOLTAGE : LESS THAN
 2 MILLIAMPS CURRENT LEAKAGE@2000 VOLTS AC. 2.5
 INSULATION RESISTANCE : 5000 MEGOHMS MIN. 2.6 IP
 CLASS : IP67 AND IP69K.
 2.7 MATING CYCLES DURABILITY : 500 CYCLES MIN. 2.8
 RoHS COMPLIANT.
 - SUITABLE CONTACTS : 2.5MM CONTACT
 16# CONTACT .
 - ALL DIMENSIONS ARE FOR REFERENCE USE ONLY.

DIMENSION ØA	CABLE OD RANGE
12.3MM	7.0-12.0MM
14.3MM	9.0-14.0MM

KEY	PART NUMBER	
		-40°C ~ +105°C
N	RTS6BS14N2S	RTS6BS14N2S03

QUANTITY	PART NUMBER	DESCRIPTION	ITEM
MATERIALS LIST			
UNLESS OTHERWISE SPECIFIED		 Sine Systems - www.amphenol-sine.com 44724 Morley Drive Clinton Township, MI 48036 ECO-MATE,PLUG,BACK SHELL, SIZE 14,2+2POS,SOCKET	
1) All dimensions are in metric (mm).			
2) PL DEC ±0.15 Angles ±1°			
3) Note reference = X			
SIGNATURES		DATE	
DRAWN: Nick		Aug-24-2017	
CHECKED: Tod		Aug-24-2017	
ENGINEER:			
APPROVAL: Tommy		Aug-24-2017	
MATERIAL SPECIFICATIONS:		CUSTOMER:	
PROCESS SPECIFICATIONS:		THIS DRAWING IS SUPPLIED FOR INFORMATION ONLY. DESIGN FEATURES, SPECIFICATIONS AND PERFORMANCE DATA SHOWN HEREON ARE THE PROPERTY OF THE AMPHENOL CORPORATION. NO RIGHTS OF REPRODUCTION ARE IMPLIED. ALL DIMENSIONS ARE SUBJECT TO NORMAL MANUFACTURING VARIATIONS.	
NEXT ASSY:		SCALE: NONE	
		SIZE: B C- TYPE: DWG NO: RTS6BS14*2S* REVISION: A3 SHEET 1 OF 1	

TITLE: ECO-MATE,PLUG,BACK SHELL,SIZE 14,2+2POS,SOCKET
 DWG NO: RTS6BS14*2S*
 REV: A3
 SH: 1
 OF: 1