



ZigBit™ Amp OEM Modules

ZDM-A1281-PN/PN0

REVISION 2.1

**Ultra-Compact 2.4GHz 802.15.4/ZigBee Modules
with Power Amplifier
for Wireless Networking Applications**



Product Datasheet

Table of Contents

Summary	3
Applications	3
Key features	3
Benefits.....	3
ZigBit™ Amp Module Overview	4
Specifications	5
Absolute Maximum Ratings***	6
Physical/Environmental Characteristics and Outline	7
Pin Configuration.....	8
Mounting Information.....	12
Soldering Profile	12
Antenna Reference Design.....	13
Related Documents	13
Ordering Information.....	14
Disclaimer.....	15
Trademarks	15
Technical Support	15
Contact Information.....	15

Summary

ZigBit™ Amp stands for ultra-compact, extended range, low-powered, high-sensitivity 2.4GHz 802.15.4/ZigBee OEM modules from MeshNetics. Based on the innovative Atmel's mixed-signal hardware platform, these modules are enhanced by an output power amplifier and an input low-noise amplifier. They are designed for wireless sensing, monitoring & control and data acquisition applications. The ZigBit Amp modules eliminate the need for costly and time-consuming RF development, and shorten time to market for wireless applications with extended range requirements.

The modules with improved range capability are designed in two versions: the ZDM-A1281-PN, with U.FL antenna connector built-in, and the ZDM-A1281-PN0, with unbalanced RF output. These modules have now expanded the ZigBit family represented before by ZDM-A1281-A2 and ZDM-A1281-B0 modules [1], [2].

Applications

ZigBit Amp features the standards-based networking stack, based on IEEE802.15.4 PHY and MAC layers, and ZigBee NWK/APS/ZDO layers. It enables multipoint, multi-hop communications over thousands of square meters at moderate data rates without expensive infrastructure support. The architecture of the Wireless Sensor Networks (WSN) allows for use of low powered devices. The applications include, but are not limited to:

- Building automation & monitoring
 - Lighting controls
 - Wireless smoke and CO detectors
 - Structural integrity monitoring
 - HVAC monitoring & control
 - Inventory management
 - Environmental monitoring
 - Security
 - Water metering
 - Industrial monitoring
 - Machinery condition and performance monitoring
 - Monitoring of plant system parameters such as temperature, pressure, flow, tank level, humidity, vibration, etc.
 - Automated meter reading (AMR)
-

Key features

- Ultra compact size (38.0 x 13.5 x 2.0 mm)
- High RX sensitivity (-104 dBm)
- Outperforming link budget (124 dB)
- Up to +20 dBm output power
- Very low power consumption:
 - 10 µA in sleep mode,
 - 23 mA in RX mode,
 - 50 mA in TX mode
- Ample memory resources (128K bytes of flash memory, 8K bytes RAM, 4K bytes EEPROM)
- Wide range of interfaces (both analog and digital):
 - spare GPIO, 2 spare IRQ lines
 - 4 ADC lines + 1 line for supply voltage control (up to 9 lines with JTAG disabled)
 - UART with CTS/RTS control
 - USART
 - I2C
 - SPI
 - 1-Wire
 - Up to 30 lines configurable as GPIO
- Capability to use MAC address written into EEPROM
- IEEE 802.15.4 compliance
- 2.4 GHz ISM band
- eZeeNet embedded software, including UART bootloader and AT command set

Benefits

- Up to 4 kilometers (2 ½ miles) outdoor line of sight range
- Ultra low power consumption combined with outperforming range
- Rapid design-in with built-in U.FL connector (ZDM-A1281-PN)
- Flexibility in using a different external antenna for every application
- Small physical footprint and low profile for optimum fit in even the smallest of devices
- Mesh networking capability
- Easy-to-use low cost Development Kit
- Single source of support for HW and SW

ZigBit™ Amp Module Overview

ZigBit™ Amp is an extended-range low-power, high-sensitivity IEEE802.15.4/ZigBee-compliant OEM module, which occupies less than a square inch of space. Based on a solid combination of Atmel's latest AVR Z-Link hardware platform, power amplifier and low-noise amplifier, the ZigBit Amp offers an unmatched combination of superior radio performance, ultra-low power consumption and exceptional ease of integration.

ZigBit Amp contains Atmel's ATmega1281V Microcontroller [3] and AT86RF230 RF Transceiver [4]. The module features 128K bytes flash memory and 8K bytes RAM.

The compact all-in-one-chip integration of output Power Amplifier and input Low-Noise Amplifier, along with RF switches enables digital control of an external RF front-end to dramatically improve ZigBit's range performance on signal transmission and increase its sensitivity. This ensures stable connectivity with larger coverage area without significant increase in module size. The HF U.FL coaxial connector [5] used in the ZDM-A1281-PN module enables the user to choose appropriate external antenna for every type of application.

The ZigBit Amp already contains a complete RF/MCU design with all the necessary passive components included. The module can be easily mounted on a simple 2-layer PCB with a minimum of required external connection. Compared to a single-chip solution, a module-based solution offers considerable savings in development time & NRE cost per unit during the design, prototyping, and mass production phases of product development.

To jumpstart evaluation and development, MeshNetics also offers a complete set of evaluation development tools. The new ZigBit Amp Development Kit [6] comes with everything you need to prototype and test an 802.15.4 or ZigBee networking solution. It includes the development boards with multiple interfaces, an out-of-the-box data acquisition software suite, as well as accessories and documentation. The sample data-acquisition application allows network monitoring and sensor data collection, all visualized via a graphic interface.

The ZigBit Amp modules come bundled with the eZeeNet networking firmware, which enables the module-based OEM products to form self-healing, self-organizing mesh networks. The eZeeNet stack conforms to IEEE802.15.4/ZigBee specifications [7], [8], [9].

Depending on end-user design requirements, the ZigBit Amp modules can operate as a self-contained sensor node, where it would function as a single MCU, or it can be paired with a host processor driving the module as it would be an RF modem.

In the former case, a user application may be used with the eZeeNet Software allowing customization of embedded applications through eZeeNet's C API.

ZDM-A1281-PN/PN0 Block Diagram

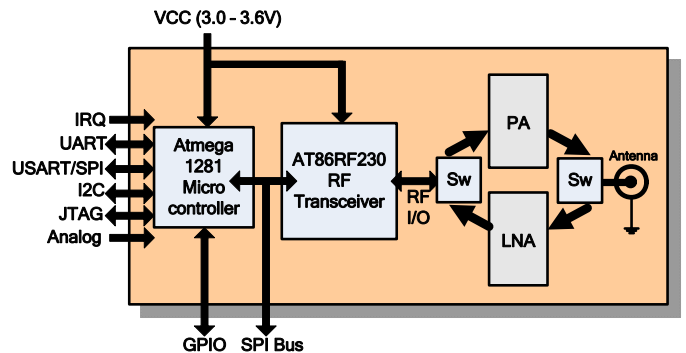

In the latter case, the host processor controls data transmission and manages module peripherals via a powerful set of AT commands. Thus, no firmware customization is required for a successful module design-in. Additionally, the sensors can be connected directly to the module, thus expanding the existing set of sensor interfaces. The over-the-air control via AT-commands eases network configuration and speeds up application prototyping. It also enables wireless module configuration during OEM mass-production process and provides flexible commissioning protocol for installation and maintenance of ZigBit Amp-based devices.

The eZeeNet is compact private profile software from MeshNetics that is specifically tailored for data acquisition applications. It allows optimizing the network traffic, reducing power consumption, scheduling, and smart power management. The eZeeNet software comes with a set of drivers for standard peripherals (I²C, GPIO, ADC, etc.) that ensure the ZigBit Amp module easy integration.

eZeeNet™ Block Diagram

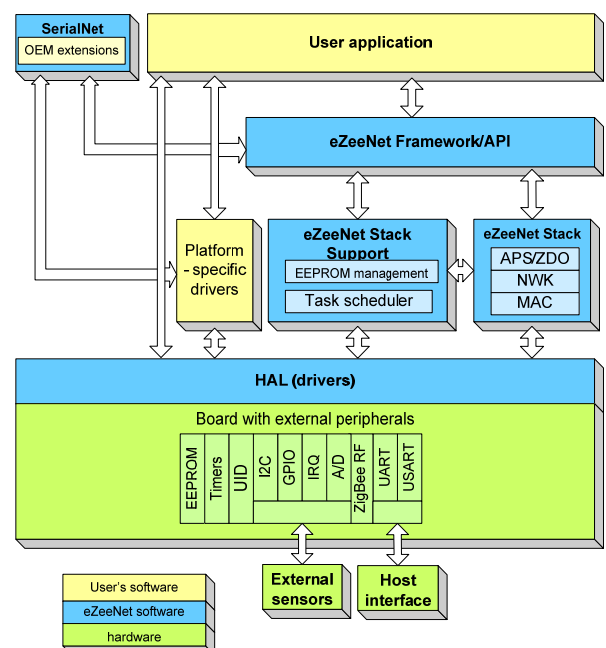

Specifications

Test Conditions (unless otherwise stated): $V_{cc} = 3.0\text{ V}$, $f = 2.45\text{ GHz}$, $T_{amb} = 25\text{ °C}$

Parameters	Range	Unit
Supply Voltage (V_{cc})	3.0 to 3.6	V
Current Consumption: RX mode*	23	mA
Current Consumption: TX mode*	50	mA
Current Consumption: Power Save mode**	< 10	μA

* Noted parameters are measured under the following conditions:

- eZeeNet Software is running at 4 MHz clock rate, DTR line management is turned off
- all interfaces are set to the default state (see *Pin Assignment Table*)
- output TX power is +20 dBm
- JTAG is not connected
- $V_{cc} = 3.0\text{ V}$.

Current consumption actually depends on multiple factors, including but not limited to, the board design and materials, eZeeNet settings, network activity, EEPROM read/write operations. It also depends on MCU load and/or peripherals used by an application.

RF Characteristics			
Parameters	Range	Unit	Condition
Frequency Band	2.400 to 2.4835	GHz	
Number of Channels	16		
Channel Spacing	5	MHz	
Transmitter Output Power	0 to + 20	dBm	Adjusted in 16 steps
Receiver Sensitivity**	- 104	dBm	PER = 1%
On-Air Data Rate	250	kbps	
TX Output / Rx Input Nominal Impedance	50	Ohms	Unbalanced RF output
Range, outdoors	Up to 4 000	m	With external 2.2 dBi antenna

** Preliminary data

<i>ATmega1281V Microcontroller Characteristics</i>			
Parameters	Value	Unit	Condition
On-Chip Flash Memory Size	128	Kbytes	
On-Chip RAM Size	8	Kbytes	
On-Chip EEPROM Size	4	Kbytes	
Operation Frequency	4	MHz	

<i>Module Interfaces Characteristics</i>			
Parameters	Value	Unit	Condition
UART Maximum Baud Rate	38.4	kbps	
ADC Resolution / Conversion Time	10 / 200	Bits / μ s	In the single conversion mode
ADC Input Resistance	> 1	MOhm	
ADC Reference Voltage (Vref)	1.0 to $V_{cc} - 0.3$	V	
ADC Input Voltage	0 to Vref	V	
I ² C Maximum Clock	222	kHz	
GPIO Output Voltage (High/Low)	2.3 / 0.5	V	(-10 / 5 mA)
Real Time Oscillator Frequency	32.768	kHz	

Absolute Maximum Ratings***

Parameter	Min Value	Max Value
Voltage of any Pin except RESET to Ground	- 0.5 V	$V_{cc} + 0.5$ V
DC Current per I/O Pin		40 mA
DC Current D_VCC and DGND Pins		300 mA
Input RF Level		+ 5 dBm

*** **Absolute Maximum Ratings** are the values beyond which damage to the device may occur. Under no circumstances must the absolute maximum ratings given in this table be violated. Stresses beyond those listed under "Absolute Maximum Ratings" may cause permanent damage to the device.

This is a stress rating only. Functional operation of the device at these or other conditions, beyond those indicated in the operational sections of this specification, is not implied. Exposure to absolute maximum rating conditions for extended periods may affect device reliability.

Attention! ZigBit Amp is ESD-sensitive device. Precaution should be taken when handling the device in order to prevent permanent damage.

Physical/Environmental Characteristics and Outline

Parameter	Value	Notes
Size, mm	38.0 x 13.5 x 2.0	
Weight, g		ZDM-A1281-PN
	~ 2	ZDM-A1281-PN0
Operating Temperature Range, °C	- 20 to +70	
Operating Relative Humidity Range, %	no more than 80%	- 40 to + 85 operational ¹

ZDM-A1281-PN/PN0 Mechanical Drawing

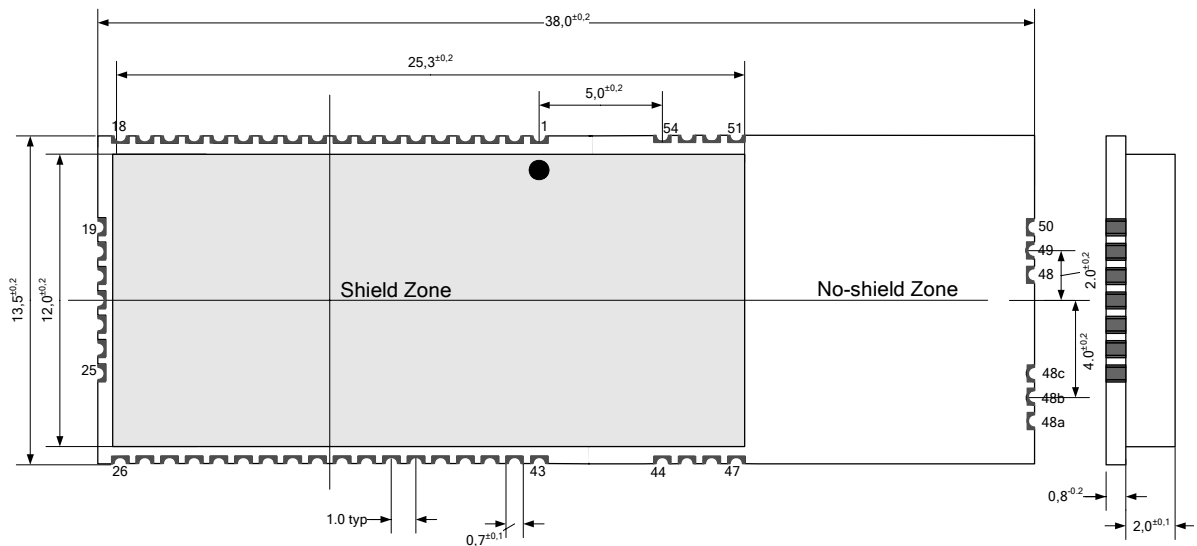

All dimensions are in millimeters

¹ Minor degradation of clock stability may occur

Pin Configuration

ZDM-A1281-PN Pinout

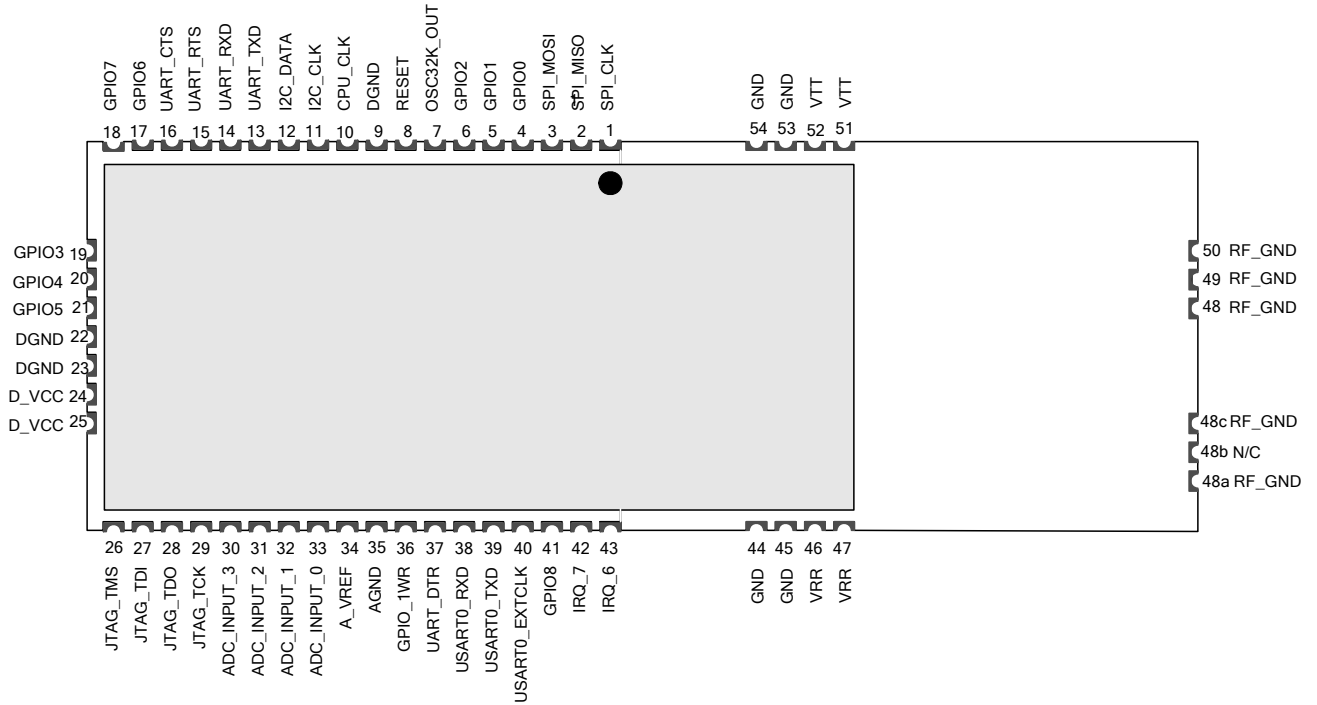

ZDM-A1281-PN0 Pinout

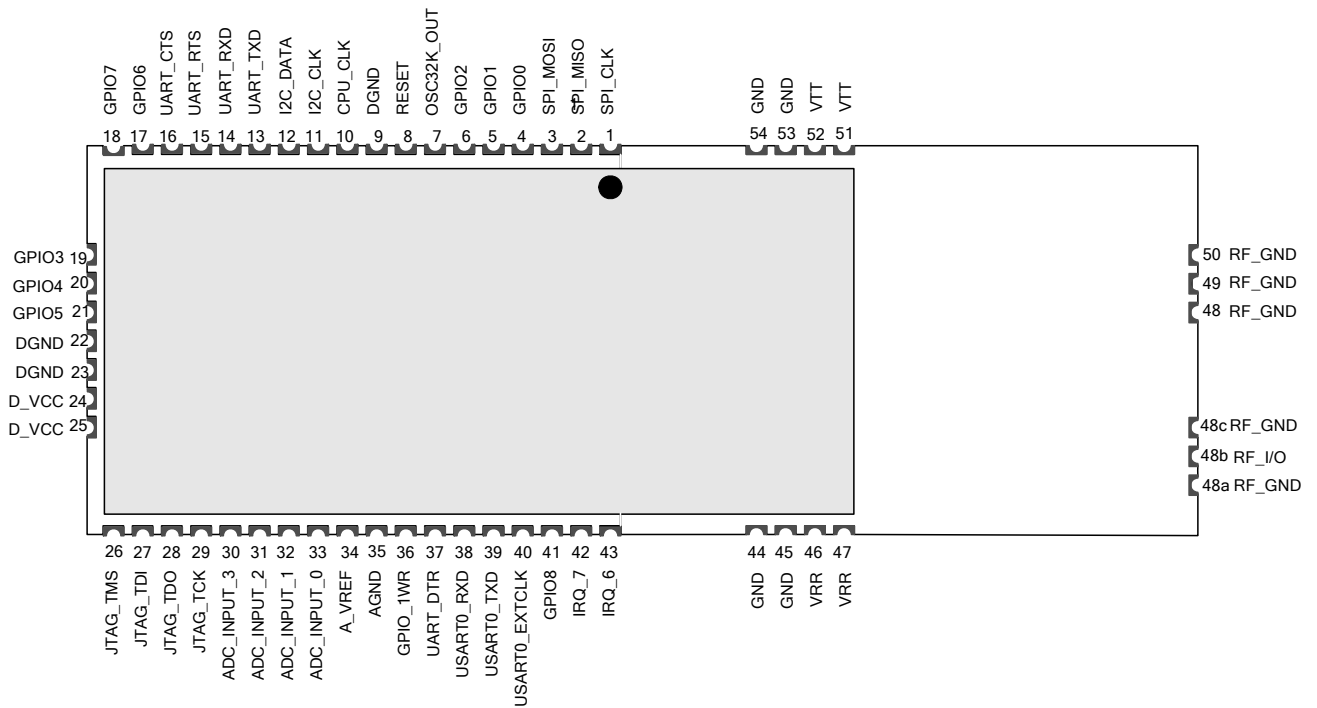

Connector Pin	Pin Name	Description	I/O	Default State after power on	Notes, see the list below
1	SPI_CLK	Reserved for stack operation	O		3
2	SPI_MISO	Reserved for stack operation	I/O		3
3	SPI_MOSI	Reserved for stack operation	I/O		3
4	GPIO0	General purpose digital input/output 0	I/O	tri-state	1, 2, 3, 6
5	GPIO1	General purpose digital input/output 1	I/O	tri-state	1, 2, 3, 6
6	GPIO2	General purpose digital input/output 2	I/O	tri-state	1, 2, 3, 6
7	OSC32K_OUT	32.768 kHz clock output.	O		3, 4
8	RESET	Reset input (active low).	I		3
9, 22, 23	DGND	Digital ground			
10	CPU_CLK	RF clock output. When module is in active state, 4 MHz signal is present on this line. While module is in the sleeping state, clock generation is stopped also.	O		3
11	I2C_CLK	I ² C serial clock output	O	tri-state	1, 2, 3, 6
12	I2C_DATA	I ² C serial data input/output	I/O	tri-state	1, 2, 3, 6
13	UART_TXD	UART receive input	I	tri-state	1, 2, 3, 6
14	UART_RXD	UART transmit output	O	tri-state	1, 2, 3, 6
15	UART_RTS	RTS input (Request To Send) for UART hardware flow control. Active low.	I	tri-state	1, 2, 3, 6
16	UART_CTS	CTS output (Clear To Send) for UART hardware flow control. Active low.	O	tri-state	1, 2, 3, 6, 7
17	GPIO6	General purpose digital input/output 6	I/O	tri-state	1, 2, 3, 6
18	GPIO7	General purpose digital input/output 7	I/O	tri-state	1, 2, 3, 6
19	GPIO3	General purpose digital input/output 3	I/O	tri-state	1, 2, 3, 6
20	GPIO4	General purpose digital input/output 4	I/O	tri-state	1, 2, 3, 6
21	GPIO5	General purpose digital input/output 5	I/O	tri-state	1, 2, 3, 6
24, 25	D_VCC	Digital supply voltage (Vcc)			8
26	JTAG_TMS	JTAG test mode select	I		1, 2, 3, 5
27	JTAG_TDI	JTAG test data input	I		1, 2, 3, 5
28	JTAG_TDO	JTAG test data output	O		1, 2, 3, 5
29	JTAG_TCK	JTAG test clock	I		1, 2, 3, 5
30	ADC_INPUT_3	ADC input channel 3	I	tri-state	1, 2, 6
31	ADC_INPUT_2	ADC input channel 2	I	tri-state	1, 2, 6
32	ADC_INPUT_1	ADC input channel 1	I	tri-state	1, 2, 6
33	ADC_INPUT_0	ADC input channel 0. Used by the stack for battery level measurement. Nominal voltage to AGND is 1 V.	I	tri-state	1, 2, 6
34	A_VREF	Output/Input reference voltage for ADC	I/O	tri-state	
35	AGND	Analog ground			

Connector Pin	Pin Name	Description	I/O	Default State after power on	Notes, see the list below
36	GPIO_1WR	1-Wire interface	I/O		1, 2, 3, 6
37	UART_DTR	DTR input (Data Terminal Ready) for UART. Active low.	I	tri-state	1, 2, 3, 6
38	USART0_RXD	UART/SPI receive pin	I	tri-state	1, 2, 3, 6
39	USART0_TXD	UART/SPI transmit pin	O	tri-state	1, 2, 3, 6
40	USART0_EXTCLK	UART/SPI external clock	I/O	tri-state	1, 2, 3, 6
41	GPIO8	General purpose digital input/output 8	I/O	tri-state	1, 2, 3, 6
42	IRQ_7	Digital input interrupt request 7	I	tri-state	1, 2, 3, 6
43	IRQ_6	Digital input interrupt request 6	I	tri-state	1, 2, 3, 6
44, 45, 48, 48a, 48c, 49, 50, 53, 54	RF_GND	RF analog ground			9
48b	RF_IO	Unbalanced 50 Ohm RF input/output	I/O		9
46, 47	VRR	Receiver supply voltage			8
51, 52	VTT	Transmitter supply voltage			8

Notes:

- Most of pins can be configured for general purpose I/O or for some alternate functions as described in details in the ATmega1281V Datasheet [3].
- GPIO pins can be programmed either for output, or for input with/without pull-up resistors. Output pin drivers are strong enough to drive LED displays directly (refer to figures on pages 387-388, [3]).
- All digital pins are provided with protection diodes to D_VCC and DGND.
- It is strongly recommended to avoid assigning an alternate function for OSC32K_OUT pin because it can be used by eZeeNet Framework. However, this signal can be used in rare cases if other peripheral or host processor requires 32.768 kHz clock, otherwise this pin should be disconnected.
- Normally, JTAG_TMS, JTAG_TDI, JTAG_TDO, JTAG_TCK pins are used for on-chip debugging and flash burning. They can be used for A/D conversion if JTAGEN fuse is disabled.
- The following pins can be configured with the eZeeNet software to be general-purpose I/O lines: GPIO0, GPIO1, GPIO2, GPIO3, GPIO4, GPIO5, GPIO6, GPIO7, GPIO8, GPIO_1WR, I2C_CLK, I2C_DATA, UART_TXD, UART_RXD, UART_RTS, UART_CTS, ADC_INPUT_3, ADC_INPUT_2, ADC_INPUT_1, BAT, UART_DTR, USART0_RXD, USART0_TXD, USART0_EXTCLK, IRQ_7, IRQ_6. Additionally, four JTAG lines can be programmed as GPIO as well, but this requires changing the fuse bits. Then, JTAG debugging would be disabled.
- With eZeeNet, CTS pin can be configured to indicate sleep/active condition of the module thus providing mechanism for power management of host processor. If this function is necessary, connection of this pin to external pull-down resistor is recommended to prevent the undesirable transients during module reset process.
- Using ferrite bead and 1 μ F capacitor located closely to the power supply pin is recommended, as shown in *Typical Application Schematics* below.
- Pins 48a, 48b and 48c are featured for ZDM-A1281-PN0 module only.

Typical Application Schematics

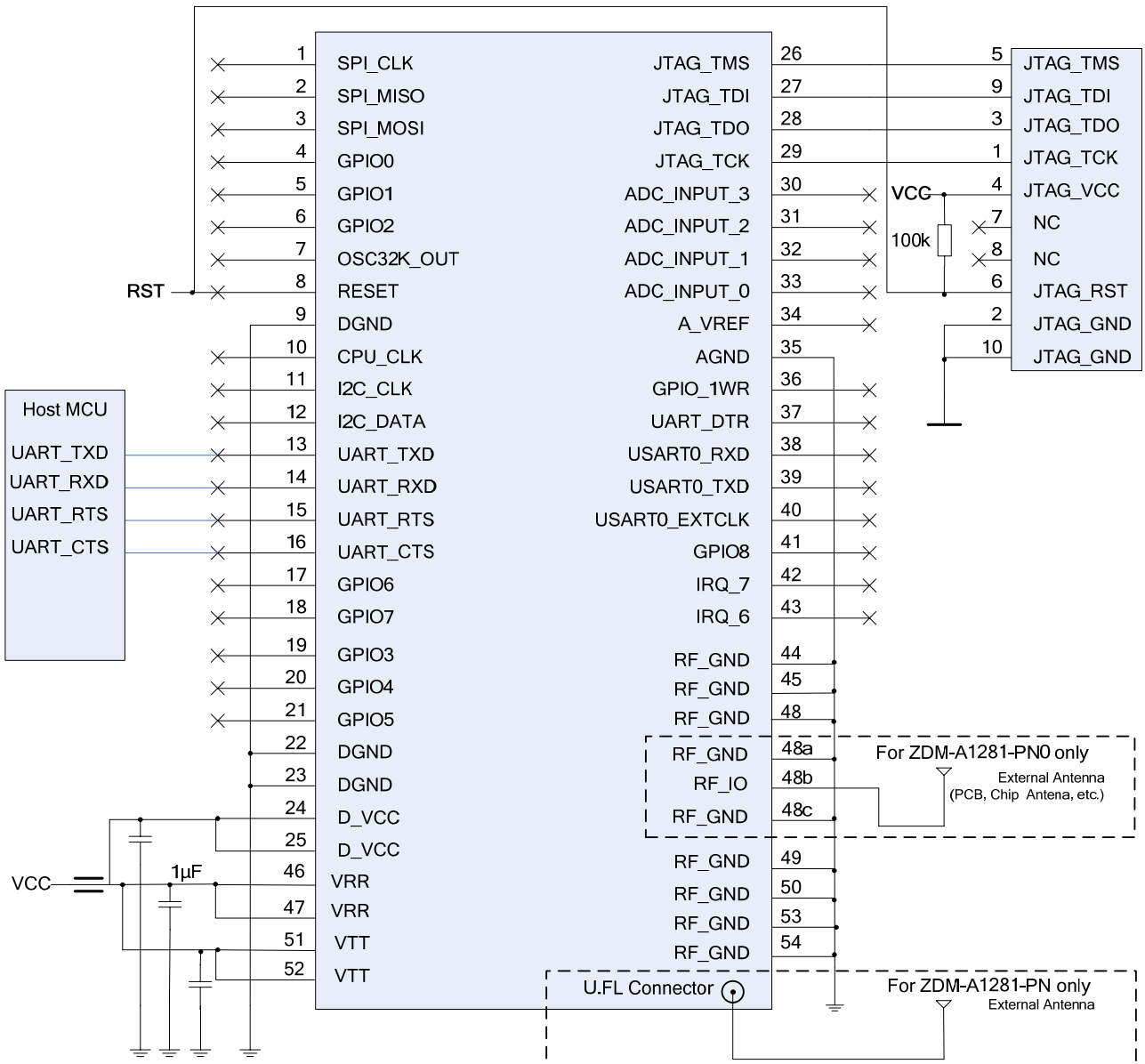

Mounting Information

ZDM-A1281-PN/PN0 PCB Recommended Layout, Top View

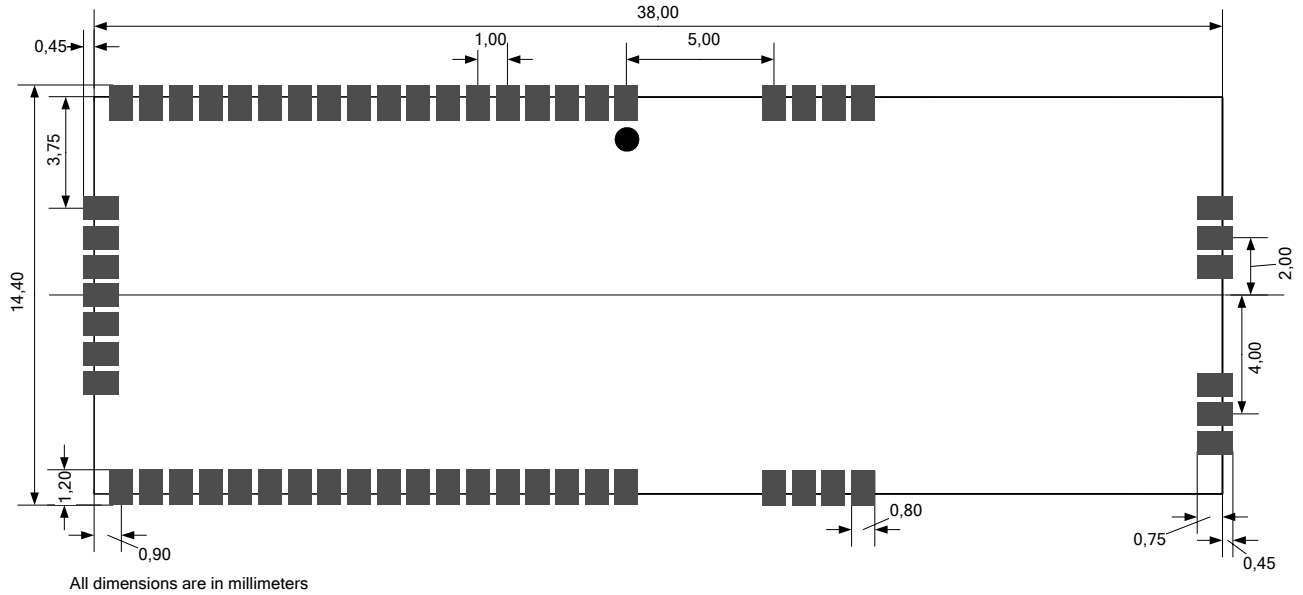

The above diagrams show the PCB layout recommended for ZigBit Amp module. Neither via-holes nor wires are allowed on the PCB upper layer in area occupied by the module. As a critical requirement, RF_GND pins should be grounded via several holes to be located right next to pins thus minimizing inductance and preventing both mismatch and losses.

Soldering Profile

The J-STD-020C-compliant soldering profile is recommended, as given below.

Soldering Profile

Profile Feature	Green Package
Average ramp-up rate (217 °C to peak)	3 °C/s max.
Preheat temperature 175 °C ± 25 °C	180 s max.
Temperature maintained above 217 °C	60 s to 150 s
Time within 5 °C of actual peak temperature	20 s to 40 s
Peak temperature range	260 °C
Ramp-down rate	6 °C/s max.
Time 25 °C to peak temperature	8 minutes max.

Note: The package is backward compatible with Pb/Sn soldering profile.

Antenna Reference Design

Multiple factors affect proper antenna match, hence, affecting the antenna pattern. The particular factors are the board material and thickness, shields, the material used for enclosure, the board neighborhood, and other components adjacent to antenna.

General Recommendations:

- Metal enclosure should not be used. Using low profile enclosure might also affect antenna tuning.
- Placing high profile components next to antenna should be avoided.
- Having holes punched around the periphery of the board eliminates parasitic radiation from the board edges also distorting antenna pattern.
- ZigBit Amp module should not be placed next to consumer electronics which might interfere with ZigBit Amp's RF frequency band.

The board design should prevent propagation of microwave field inside the board material. Electromagnetic waves of high frequency may penetrate the board thus making the edges of the board radiate, which may distort the antenna pattern. To eliminate this effect, metalized and grounded holes must be placed around the board's edges.

Related Documents

- [1] ZigBit™ OEM Modules ZDM-A1281-*. Product Datasheet. MeshNetics Doc. M-251~01
- [2] ZigBit™ Development Kit. User's Guide. MeshNetics Doc. S-ZDK-451~01
- [3] Atmel 8-bit AVR Microcontroller with 64K/128K/256K Bytes In-System Programmable Flash. 2549F-AVR-04/06
- [4] Atmel Low-Power Transceiver for ZigBee Applications. AT86RF230 Target Specification. 5131A-ZIGB-08/15/05
- [5] Ultra Small Surface Mount Coaxial Connectors - Low Profile 1.9mm or 2.4mm Mated Height. http://www.hirose.co.jp/catalogue_hp/e32119372.pdf
- [6] ZigBit™ Amp Development Kit. User's Guide. MeshNetics Doc. S-ZDK-451~02
- [7] IEEE Std 802.15.4-2003 IEEE Standard for Information technology – Part 15.4 Wireless Medium Access Control (MAC) and Physical Layer (PHY) Specifications for Low-Rate Wireless Personal Area Networks (LR-WPANs)
- [8] ZigBee Specification. ZigBee Document 053474r14, November 03, 2006
- [9] eZeeNet™ IEEE802.15.4/ZigBee Software. Product Datasheet. MeshNetics Doc. M-251~02

Ordering Information

Contact MeshNetics for ordering ZigBit Amp modules and/or ZigBit Amp Development Kit.

Please specify the product part number and description when ordering ZigBit Amp modules:

Part Number	Description
ZDM-A1281-PN	2.4 GHz IEEE802.15.4/ZigBee Power Amplified OEM Module with U.FL Antenna Connector
ZDM-A1281-PN0	2.4 GHz IEEE802.15.4/ZigBee Power Amplified OEM Module with Unbalanced RF Output

The ZigBit Amp Development Kit is offered with **2 support packages**:

- **ZigBit Amp Development Kit Lite** offers access to standard evaluation and development tools and comes with 45 days of complimentary support. This option is good for product demonstration, platform evaluation and quick application prototyping.
- **ZigBit Amp Development Kit Complete** comes with 1 year of professional support which provides users with continuous software updates, dedicated design-in support, and RF design assistance. It's ideal for customers engaged in a full cycle of developing, prototyping, and launching innovative products made possible by MeshNetics ZigBit wireless platform. It also features early software release access, and additional sample applications, including sources for WSN Demo application, examples of API use, and more.

ZDK Edition	Lite	Complete
Part Number	ZDK-A1281-PN-LTE	ZDK-A1281-PN-CPT
Support Duration	45 days	1 year
Hardware design support	+	+
RF design support	+	+
Software development support	+	+
Early software release access ²	-	+
Access to Gerber Files ³	-	+
Access to bootloader source code ⁴	-	+
Additional sample applications ⁵	-	+
SerialNet Extensions ⁶	-	+
Response time	72 h, workdays	72 h, workdays
Support channel	E-mail	E-mail

² Early software release access covers technology previews and demos, preliminary datasheets, and advance product announcements.

³ MeshBean Gerber files greatly expedite custom PCB design-in and accelerate TTM for customer's specific products based on ZigBit modules and peripherals used within MeshBean development platform such as USB extension, sensor adaptations and others.

⁴ Access to serial bootloader source code is essential in building custom tools for serial and OTA upgrades.

⁵ Additional sample applications include sources for (1) the embedded portion of WSN Demo, featuring the most comprehensive example of a typical data acquisition scenario, (2) smaller examples of API use, which may be used as application "building blocks", (3) sample applications featuring integration of ZigBit w/ 3-rd party sensors.

⁶ SerialNet Extensions allow customer to extend the AT command set with their own commands. This software simplifies commissioning, eases software design-in, and allows customers to control 3-rd party sensors of their choice via AT commands.

Disclaimer

MeshNetics believes that all information is correct and accurate at the time of issue. MeshNetics reserves the right to make changes to this product without prior notice. Please visit MeshNetics website for the latest available version.

MeshNetics does not assume any responsibility for the use of the described product or convey any license under its patent rights.

MeshNetics warrants performance of its hardware products to the specifications applicable at the time of sale in accordance with MeshNetics standard warranty. Testing and other quality control techniques are used to the extent MeshNetics deems necessary to support this warranty. Except where mandated by government requirements, testing of all parameters of each product is not necessarily performed.

Trademarks

MeshNetics®, ZigBit, eZeeNet, ZigBeeNet, SensiLink, LuxLabs, Luxoft Labs, and MeshNetics, Luxoft Labs and ZigBit logos are trademarks of LuxLabs Ltd, dba MeshNetics.

All other product names, trade names, trademarks, logos or service names are the property of their respective owners.

Technical Support

Technical support is provided by MeshNetics.

E-mail: support@meshnetics.com

Please refer to Support Terms and Conditions for full details.

Contact Information

MeshNetics

EMEA Office
Am Brauhaus 12
01099, Dresden, Germany
Tel: +49 351 8134 228
Office hours: 8:00am - 5:00pm (Central European Time)
Fax: +49 351 8134 200

US Office
5110 N. 44th St., Suite L200
Phoenix, AZ 85018 USA
Tel: (602) 343-8244
Office hours: 9:00am - 6:00pm (Mountain Standard Time)
Fax: (602) 343-8245

Russia Office
9 Dmitrovskoye Shosse, Moscow 127434, Russia
Tel: +7 (495) 725 8125
Office hours: 8:00am - 5:00pm (Central European Time)
Fax: +7 (495) 725 8116

E-mail: info@meshnetics.com

www.meshnetics.com

© 2007 MeshNetics. All rights reserved.

No part of the contents of this manual may be transmitted or reproduced in any form or by any means without the written permission of MeshNetics.