

DO NOT SCALE DRAWING

REVISION

A	INITIAL DRAWING 03.11.17 DW
B	SIZE M3 x 6 ADDED 16.05.18 DW

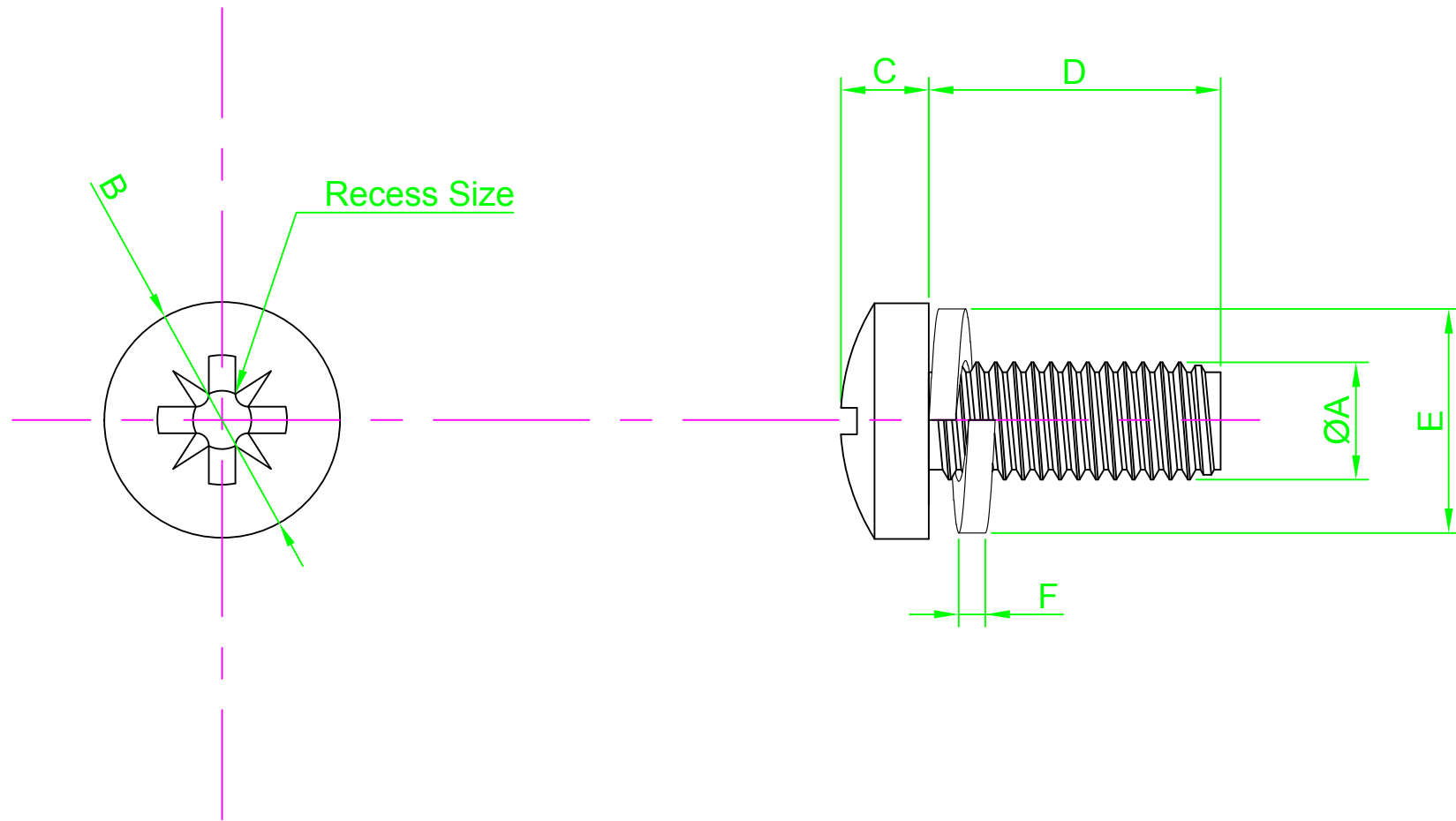

Part Number	ØA	B Max	C Min	Recess Size	D	E Max	F
M4 6 PRSTSR Z100	M4-0.7	8.0	2.66	Pozi #2	6.0	6.10	0.8 ± 0.1
M3 6 PRSTSR Z100	M3-0.5	7.0	1.96	Pozi #1	6.0	7.55	0.9 ± 0.1

NOTES:



UNLESS OTHERWISE SPECIFIED:
DIMENSIONS ARE IN MM (MILLIMETERS).
SURFACE FINISH:
TOLERANCES:

	NAME	DATE
DRAWN	Darryl Wilson	03.11.17
CHK'D		
APPV'D		

MATERIAL:
Steel

HEAT TREATMENT:

TITLE:
Pozi Pan Head Machine Screw c/w
SEMS Rectangular Section Spring Washer

DESIGN RIGHT. TR FASTENINGS LTD, 2003
UNDER NO CIRCUMSTANCES MUST THIS
DRAWING BE COPIED OR DISCLOSED
WITHOUT FIRST OBTAINING WRITTEN
AUTHORITY.

CUSTOMER PART NUMBER:
N/A

FINISH:
Commercial Zinc/Clear Trivalent

DRAWING NUMBER:
TR32PRSTSR

A4

