

1 Introduction

This document describes a 4 channel temperature measurement system: The New Smart temperature Acquisition System (SMTAS04usbmini). It is based on the use of the Smartec temperature sensors SMT172. The SMT172 is a three terminal integrated temperature sensor with a duty cycle output. Two terminals are used for the power supply of and the third terminal carries the output signal. The output signal of the sensor is a duty-cycle-modulated square-wave signal (see Figure 1).

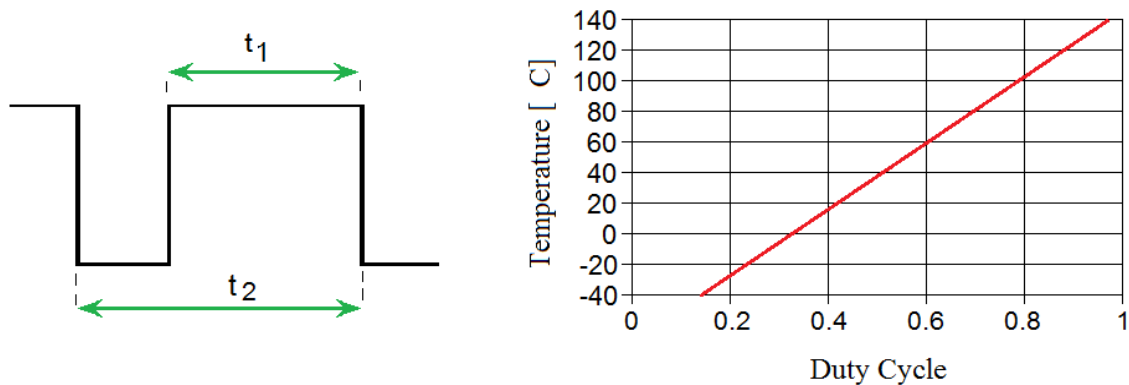

Figure 1 (a) Output signal of the SMT172 temperature sensor, (b) Relation between the duty-cycle and the temperature. $DC = t_1/t_2$

After measuring both t_1 and t_2 , the temperature in °C can be calculated by equation:

$$T = \frac{DC - 0.32}{0.0047} = 212.77 \times DC - 68.085$$

SMTAS04USB mini – Evaluation board for SMT172

However in the SMTAS04USB there is the more accurate formula implemented :

$$T = -1.43 DC^2 + 214.56 DC - 68.60$$

DC = Duty Cycle

T = temperature in °C

The temperature sensors are sold separately from the SMTAS04usb board. The SMT172 temperature sensor is available in different encapsulations (TO18, TO92, TO220, etc), each with their specific properties. Very important to point your attention to, is the accuracy of SMT172 sensors. The TO18 version yields the most accurate sensor and has an accuracy of 0.1 °C in a limited temperature range (-10 to +100 °C). The complete specification of the temperature sensor range is presented in the datasheet, which should be consulted in conjunction with this document.

The SMTAS04usb is equipped with a STM32 is Cortex M0+ (32 bit architecture from ARM) microcontroller. An USB (Virtual COM port) interface offers external communication with the microcontroller. Therefore we refer to our publication “USB to PC” which can be found in <http://notes.smartec-sensors.com>

A bug in Windows 7 and higher?

When you connect the USB board to the com port you have to look to the “device manager” from the control board. You can find under “Mice and other pointing devices” maybe the “Microsoft serial Ballpoint”. It pops up when connecting the USB board Disable this (not remove) Ball Point and plug in again the USB board. Then probably your will find under mice and other pointing devices the disabled “Microsoft Ballpoint” and under comports what you are looking for. Try again then; this happens at our clients several times. It is a bug in windows and has cost us also about 4 days to find out.

The four connected sensors are powered on 3.3 Volt for minimal self-heating. After measurement of all required sensors the software calculates the four temperatures. The microcontroller captures 2 DEM cycles and calculate the averaged duty cycle. (For more information refer to documents of SMT172). Each calculated average duty cycle is sent via USB port.



SMTAS04USB mini - Evaluation board for SMT172

2 Circuit diagram and PCB layout

Temperature Sensor Board Schematic in figure 2 and figure 3.

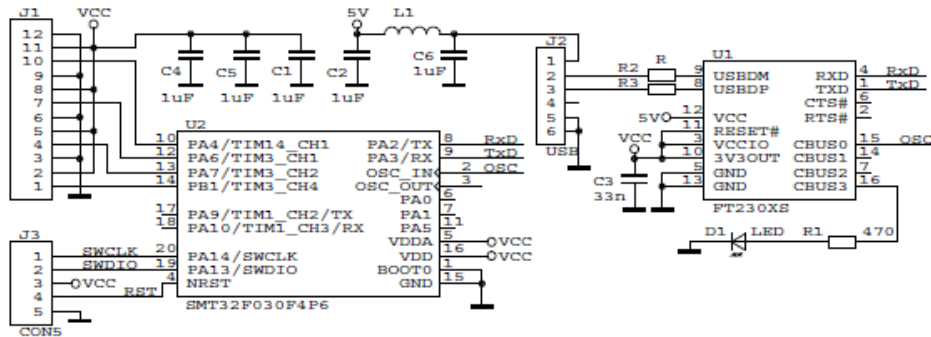
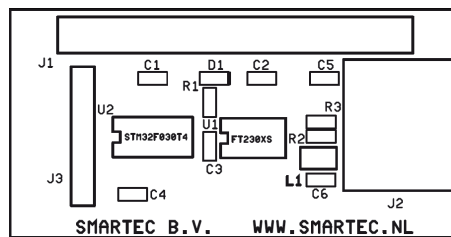

Figure 2 Circuit diagram of the SMTAS04USBmini board



Holes 4 x 2 mm Ø 35 x 26 mm □

Figure 3 PC-board layout and connector position

Connector J1:

1	Output sensor 1	2	Vcc sensor1	3	Gnd sensor 1
4	Output sensor 2	5	Vcc sensor 2	6	Gnd sensor 2
7	Output sensor 3	8	Vcc sensor 3	9	Gnd sensor 3
10	Output sensor 4	11	Vcc sensor 4	12	Gnd sensor 4

Connector J2 Standard miniature USB connector

Connector J3 For programming micro controller



SMTAS04USB mini – Evaluation board for SMT172

3 Measuring

This small PC-board is only developed as a demonstrator to show the ease of interfacing temperature sensors to micros. For logging purposes Smartec has available a special temperature logging program on the website. The temperature will be represented on the USB port as ascii value, in case no sensor is connected an “*” will come out. Easy to read with **HyperTerminal** or **Putty** or any other terminal program.

With a little **Delphi** program that can be downloaded from our website

<http://notes.smartec-sensors.com> one can read out the 4 sensors in parallel with a graph on the screen. Another way for saving the measured data on the PC is by means of a “CVS” file.

4 Ordering information

SMTAS04USBmini Smartec interface board for 4 SMT temperature sensors and an USB output.

SMTAS08USBmini Smartec interface board for 8 SMT temperature sensors and an USB output

SMT172-T018	Smartec temperature sensor in T018 encapsulation (metal can)
SMT172-T092	Smartec temperature sensor in T092 encapsulation (commercial)
SMT172-T0220	Smartec temperature sensor in T0220 encapsulation
SMT172-SOIC-8L	Smartec temperature sensor in SOIC8 encapsulation
SMT172-SOT223	Smartec temperature sensor in SOT223 encapsulation
SMT172-HEC	Smartec temperature sensor as small hybrid (2.5. x 8 mm)

sales@smartec-sensors.com

