



Contents

Contents.....	1
Product Overview.....	2
Communications Protocol.....	3
LCD Display	4
Part Ordering Details - Storm Products	6
Part Details - Other Hardware Required (depending on end application)	6
Part Details - Other Hardware Required (depending on end application)	7
Part Details - Other Hardware Required (depending on end application)	8
Connecting the Encoder to a 4-Way Keypad.....	11
Connecting the Encoder to a 12 or 16 Way Keypad – Telephone Layout	13
Connecting the Encoder to a 12 or 16 Way Keypad – Calculator Layout	15
Connecting the Encoder to the Storm 5000 Series Integrated Keypad.....	17
Connecting the Encoder to Storm 6000 Keypads.....	19

NOTICE

This document is provided for use and guidance of engineering personnel engaged in the installation or application of Storm Interface data entry products manufactured by Keymat Technology Ltd. Please be advised that all information, data and illustrations contained within this document remain the exclusive property of Keymat Technology Ltd. and are provided for the express and exclusive use as described above. This document is not supported by Keymat Technology’s engineering change note, revision or reissue system. Data contained within this document is subject to periodic revision, reissue or withdrawal. Whilst every effort is made to ensure the information, data and illustrations are correct at the time of publication, Keymat Technology Ltd. are not responsible for any errors or omissions contained within this document.

No part of this document may be reproduced in any form or by any means or used to make any derivative work (such as translation or adaptation) without written permission from Keymat Technology Ltd.

For more information about Storm Interface and its products, please visit our website at

www.storm-interface.com

©Copyright Storm Interface. 2017

All rights reserved



Product Overview

The Storm 420 Series Encoder provides a serial interface between keypad and host system. It can be supplied either as a separate encoder module or pre-assembled into a Storm keypad to suit end user requirements.

Features / Specifications

Input Power + 5V \pm 0.25V dc

RS232 Output via 6 pin Molex 2.54mm (.100") Pitch KK® Series Connector

Drives Powertip 80 Character LCD Display from keypad

Direct connection to underpanel mounted 12 key, 16 key, 20 key Storm Keypads.

Ribbon Cable needed for top panel fixing 4 key, 12 key, 16 key Storm Keypads

Overall Footprint 89mm x 66mm

Mounting Centres at 43.2mm and 73.5mm (3mm holes provided for pcb standoffs)

Electromagnetic Compatibility (EMC)

Storm 420 Series Encoders are classified as a component with regard to the European Community EMC regulations. It is the equipment manufacturers responsibility to ensure that systems using the Storm 420 Series Encoder are compliant with the appropriate EMC standards.

If the electronic system requires input protection against high voltage transients (to meet CE requirements) it is recommended that an external interface board is located at the point where the external wiring enters the electronic system enclosure.

Using the 420 Series Encoder with Storm 5000 Series Integrated Keypads

As a combination the Storm Integrated Keypad/ Display Module with Encoder forms a complete serial communications device. Alphanumeric output from the unit is communicated via the familiar RS232 physical link layer.

The keypad has 20 keys including ten numeric keys and a further ten special function keys. The LCD module displays 80 characters across 4 lines. Both the keypad and LCD module may be backlit from the controller board.

The module has been designed in such a way that it can be used as part of an embedded application, possibly using a separate host microcontroller or PC to communicate with the module. Alternatively it may be used as an input interface since the keypad and LCD functions have been designed to be familiar to most users.

The keypad is arranged as a 5-row, 4 column matrix and is scanned and debounced by the module's built-in microprocessor. The debounce filter is set at 64ms. No typematic key rollover function is implemented. Multi-key lockout is, however, implemented in the firmware.

Use of 420 Series Encoder to provide RS232 output from Storm K Range Keypads

When used with any Storm Interface matrix keypad, the encoder can either be fitted directly to the rear of the keypad, or connected via a ribbon cable. Please note that the cables required to connect a keypad to the encoder are custom cables and are not provided by Storm.

The encoder can either be fitted directly to the rear of a standard Storm K Range Keypad, or remotely by a ribbon cable.

Where Storm K Range Keypads are underpanel mounted the 420 Encoder can be directly connected, requiring no additional mounting hardware.

The overall depth required to house the 420 Encoder is 32mm (1.25in) when measured from back of keypad. Where Storm K Range Keypads are fixed to a panel surface, a ribbon cable and mounting hardware are required (these items not included with encoder)



Communications Protocol

Physical Link Layer

The module transmits and receives data using RS232 signalling with a voltage swing of approximately $\pm 9V$. DIP Configuration Switch 8 selects between 9600 baud (DIP switch off) and 1200 baud (DIP Switch on). In both conditions, 8-bit data is used with no parity and one stop bit. This may be summarised as follows....

DIP8 OFF	9600,8,N,1
DIP8 ON	1200,8,N,1

No software or hardware handshaking is used since the data rate is low relative to the bandwidth of the communications protocol.

Only the TX, RX and Ground signals are employed. The chosen nomenclature is that TX means transmission out of the module.

Data buffering

Both data transmission and reception are controlled by the module's built in microprocessor using a pair of stacks- one for transmitted characters and one for received characters. These allow the application to send data to and from the unit largely without consideration of the timing constraints of the RS232 physical link layer.

Provided the stacks are not filled, data can be freely sent to and received from the module and the module will buffer the characters until such times as it is able to process them.

The buffer sizes are as follows...

Data transmission (keypad data out of module)	16 bytes
Data reception (LCD data into module)	48 bytes

Should the buffers be filled, further characters will not be pushed onto the stacks, but instead are discarded.

Character echoing

Characters received from the host terminal/microprocessor may be echoed back to the host by setting DIP Configuration Switch 2 to ON. With DIP Switch 2 OFF the characters are not echoed.

Characters resulting from key strokes are never echoed to the LCD display, but are simply sent via the RS232 TX pin to the host application.



LCD Display

The LCD display comprises 80 characters in all, arranged as 20 characters on each of 4-lines. The full range of standard ASCII characters are available, including lower case letters. Some, but not all, of the extended ASCII characters are available. Appendix 3 lists the available characters.

Power-up message

At power-on the LCD display shows hardware and software version numbers and communications information for a period of approximately 5 seconds. After this time the display automatically clears and the cursor is located at the first character on the left of line 1.

LCD operating principles

The LCD interface is designed to be suitable either for keypad data input (for example as a data entry terminal) or for embedded microprocessor applications.

It has been designed to operate in a similar way to a teletype terminal since this is a familiar environment to most users and is consequently intuitive.

The cursor begins on the left of line 1. Entered characters move the cursor progressively further to the right of line 1 until the end of the line is reached. Entering one further character automatically moves the cursor to the beginning of line 2, i.e. automatic text wrapping is implemented. This applies to all lines.

Once the end of line 4 is reached, entering one further character results in all lines moving up one place, resulting in the contents line 1 being discarded, line 2 moves to line 1, line 3 moves to line 2 and line 4 moves to line 3. Line 4 is subsequently cleared and the cursor moves to the beginning of line 4.

Special characters

The Carriage Return key is supported (ASCII character 0x0D) and results in the cursor moving to the beginning of the next line, exactly as described above. The Line Feed key (ASCII character 0x0A , or Ctrl-J in HyperTerminal) is also supported and gives the same functionality as carriage return.

The backspace key (ASCII character 0x7F) and Del key (ASCII character 0x08) may be used to delete the last entered character and move the cursor back one place. This can be repeated until the cursor is at the beginning of the current line, but no further (exactly as a teletype terminal).

The Tab key (ASCII character 0x09) is supported, and enters four spaces, even if this involves a line-wrap.

The Form Feed key (ASCII character 0x0C, Ctrl-L in HyperTerminal) is implemented as a 'clear screen' function and returns the cursor to the beginning of line 1..



Typical implementations

An embedded application where the LCD is written to by a separate microprocessor or computer would typically send a Form Feed character followed by up to 80 characters, possibly interspersed with carriage returns to reduce the number of characters to be transmitted.

It is unlikely that such an application would make use of the backspace function since there are unlikely to be errors in data entry, although the line-wrap feature may be used to allow the microprocessor to treat the display as a contiguous array of 80 characters with no requirement for carriage returns.

A terminal-like application, however, where the user is permitted to type any characters on the LCD (perhaps using an application such as HyperTerminal) would almost certainly make use of all the features built into the module such as line-wrap and special characters to make the interface more user friendly.

LCD adjustment

A potentiometer is provided on the module interface circuit board to allow the contrast of the LCD display to be adjusted. Wide Temp Range Displays require 0V to -9V ; Std Temp Range Displays require 0V to +5V

Supported Displays

POWERTIP TECHNOLOGY CORP.

20 Char x 4 Line Display PC 2004LRU-AWA-H, PC 2004LRU-ASO-H Wide Temp Range

Pin	Symbol	Function
1	Vss	Power supply(GND)
2	Vdd	Power supply(+)
3	Vo	Contrast Adjust
4	RS	Register select signal
5	R/W	Data read / write
6	E	Enable signal
7	DB0	Data bus line
8	DB1	Data bus line
9	DB2	Data bus line
10	DB3	Data bus line
11	DB4	Data bus line
12	DB5	Data bus line
13	DB6	Data bus line
14	DB7	Data bus line
15	A	Power supply for LED B/L (+)
16	K	Power supply for LED B/L ()

Part Ordering Details - Storm Products

4200-00[x]	RS232 Encoder
4200-101	Ribbon Cable 16 Way, 65mm long for LCD Connection for use with FT5000 Integrated
5001-000201	LCD 4 x 20 Powertip Display

Part Details - Other Hardware Required (depending on end application)

Cable for +5V Supply Two wire with tinned ends

Cable for PC Connection Cable 6 Way Molex KK to Serial Port as drawing below

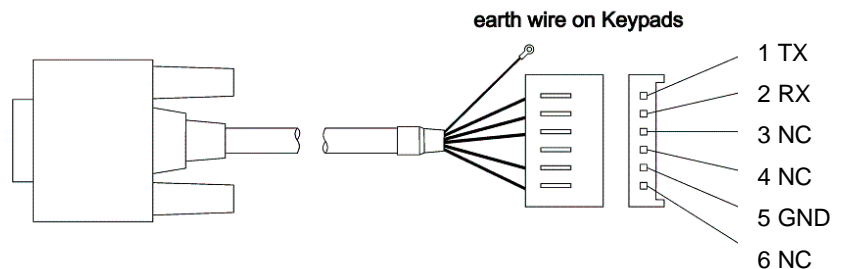
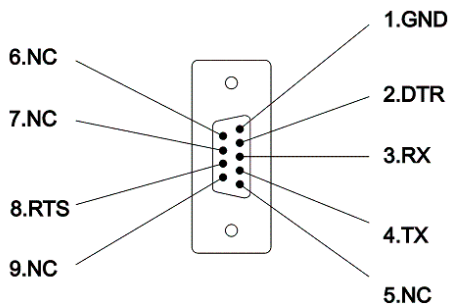

9 Way portable PC cable.
RS part number 758-7541 (cut one cable to make two assemblies)

2.54mm Pitch KK Crimp Terminal housing 6-Way with locking ramp.
RS part number 296-4984 or Molex Part number 22-01-2065.
1 - off required

KK Crimp terminals.
RS part number 467-598 or Molex Part number 08-50-0032.
6 - off required.

Yellow M3.5mm crimp ring terminal.
RS part number 534-468.
1 - off required.

Part Details - Other Hardware Required (depending on end application)

Cable for LCD Connection Ribbon Cable 16 Way

Buy direct from Samtec.
Part number IDSS-16-D-X.X (X is the length specified in inches).

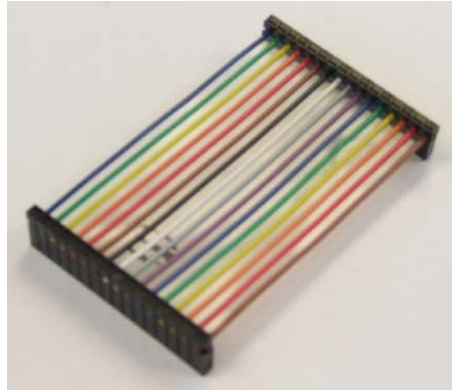

Cable for 4 Way Keypad

Ribbon Cable 5 Way Molex KK to bare ends

2.54mm Pitch KK Crimp Terminal housing 5-Way with locking ramp, RS part number 679-5385P or Molex Part number 22-01-3057.
1 - off required

KK Crimp terminals. RS part number 467-598.
Molex Part number 08-50-0032.
5 - off required.

2.54mm Ribbon cable length to suit application.
RS part number 214-0661
This is a 10-way cable, tear down to make a 5 way

Bare ends to be soldered to encoder.

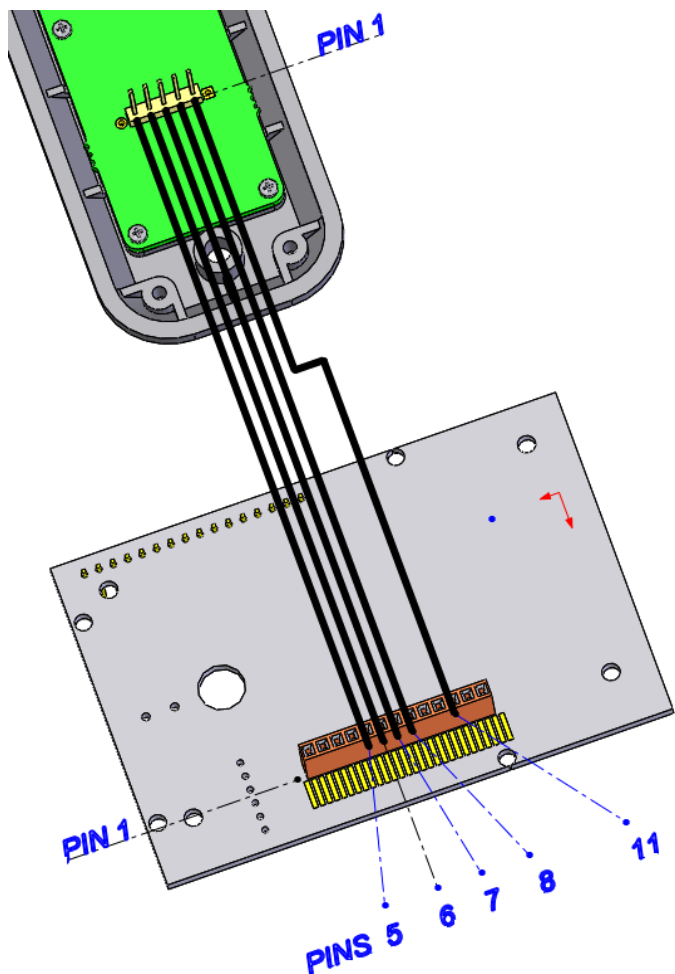

Part Details - Other Hardware Required (depending on end application)

Cable for 4 way Backlit Keypad

Ribbon Cable 7 Way Molex KK to bare ends

2.54mm Pitch KK Crimp Terminal housing 7-Way with locking ramp.
RS Components 679-5404P.
Molex Part number 22-01-3077.
1 - off required

KK Crimp terminals. RS part number 467-598.
Molex Part number 08-50-0032.
7 - off required.

2.54mm Ribbon cable length to suit application.
RS part number 214-0661
This is a 10-way cable , three ways should be stripped off before assembly.

Bare ends to be soldered to encoder.

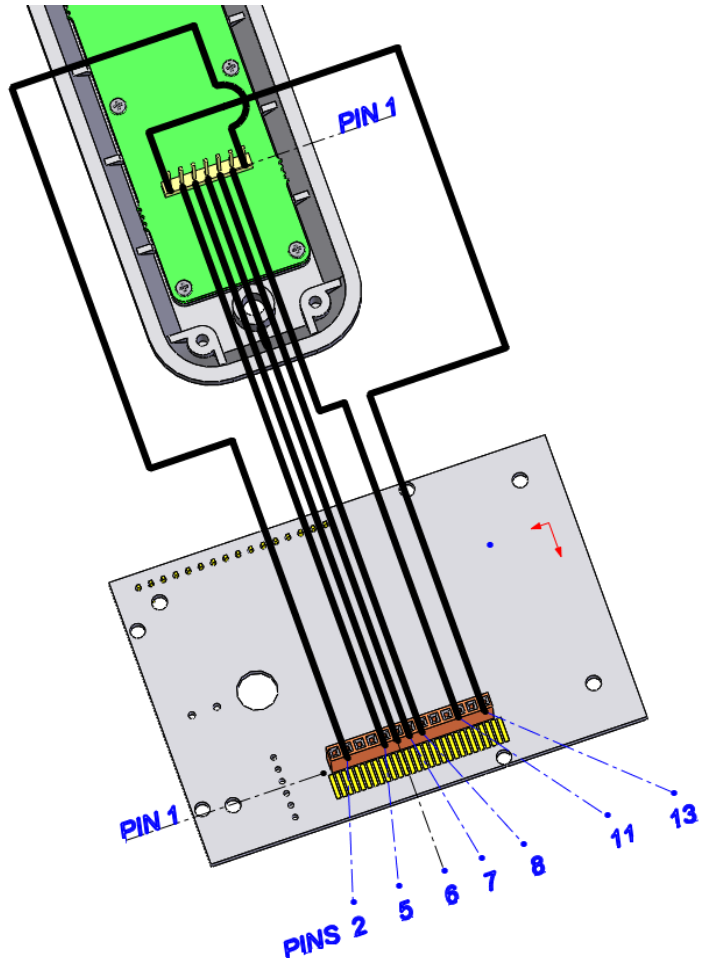
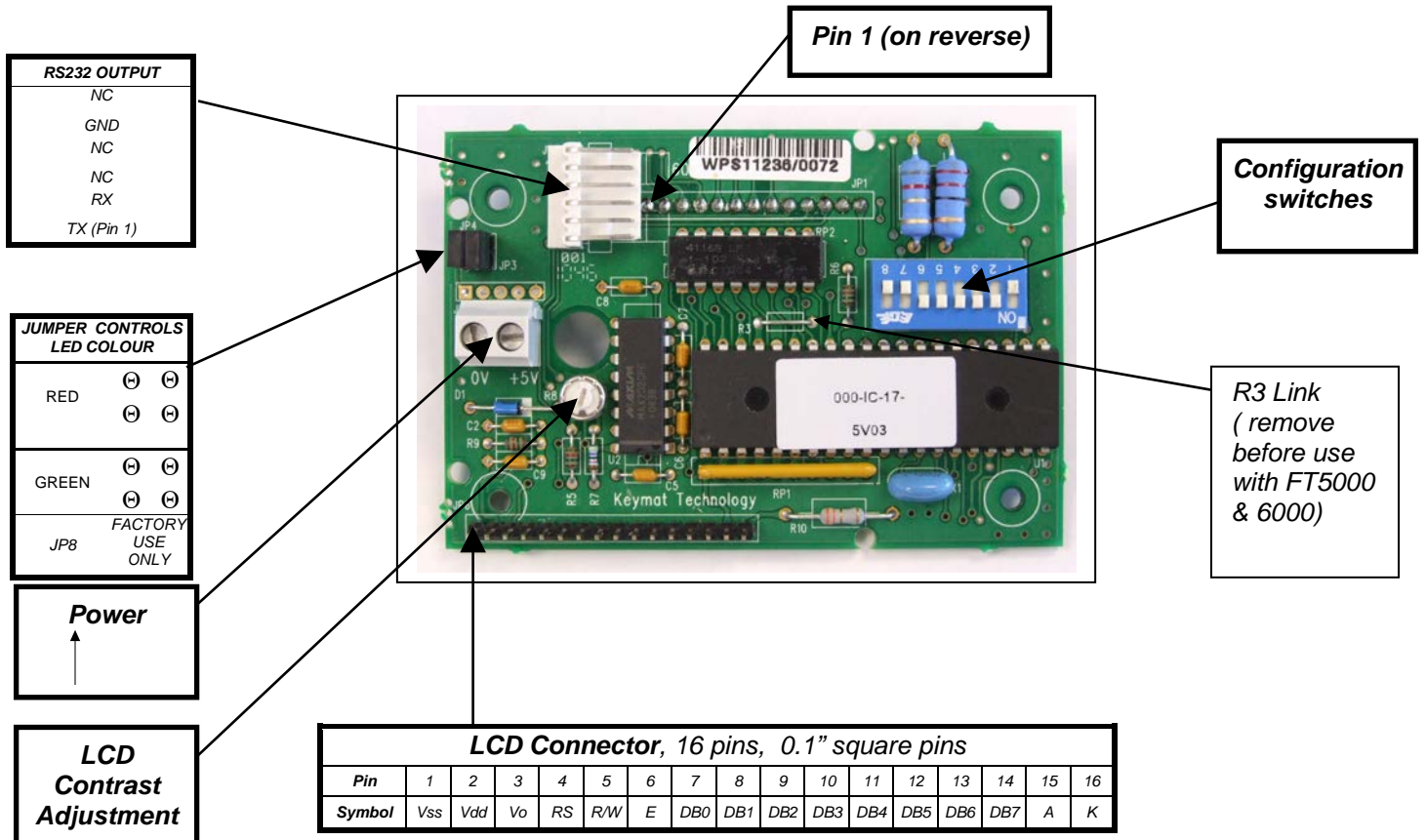

Table of Encoder Connections

Keypad Connector (on reverse of pcb)												✓ = pin connection made		Direct connection to rear of keypad ?			
KEYPAD TYPE																	
6000 Series	Fit polarisin pin	✓	✓	✓	✓	✓	✓	✓	✓	✓	✓	✓	✓	✓	✓	Fit polarising pin	YES —fit polarising pins to positions 1and 13
FT5000	Fit polarising pin	✓	✓	✓	✓	✓	✓	✓	✓	✓	✓	✓	✓	✓	✓	Fit polarising pin	YES —fit polarising pins to positions 1and 13
12 / 16 WAY BACKLIT	Fit polarising pin	✓	✓	✓	✓	✓	✓	✓	✓	✓	✓	✓	✓	✓	✓	Fit polarising pins	YES —fit polarising pins to positions 1,12 and 13
12 / 16 WAY NOT BACKLIT	Fit polarising pins	✓	✓	✓	✓	✓	✓	✓	✓	✓	✓	✓	✓	✓	✓	Fit polarising pins	YES
4 WAY BACKLIT	Fit polarising pin	✓	Fit polarising pin	✓	✓	✓	✓	✓	✓	✓	✓	✓	✓	✓	✓	Fit polarising pin	NO —separate cable required STD version needs 5 way cable BACKLIT version needs 7 way cable Fit polarising pins as required
4 WAY NOT BACKLIT	Fit polarising pins	✓	✓	✓	✓	✓	✓	✓	✓	✓	✓	✓	✓	✓	✓	Fit polarising pins	

Encoder Pin	1	2	3	4	5	6	7	8	9	10	11	12	13
LED CATHODE											R5 FUNCTION KEYS	TAMPER OUT	LED ANODE
TAMPER IN													
R1													
R2													
C1													
C2													
C3													
C4													
R4													
R3													
PIN 1 ON REVERSE													



The Product Identification Code is shown on the label on the encoder. The (non-upgradeable) firmware version is shown on the back of the controller eg Version 5.03 (or alternatively 5v03)



THIS PAGE INTENTIONALLY LEFT BLANK

Connecting the Encoder to a 4-Way Keypad

Storm 4-way keypads are the only keypad types that require a cable in order to be connected to the encoder; all other types of keypad can be connected directly to the encoder.

Before you connect the encoder to a 4-way keypad, make sure you have:

- A 5 way Molex cable to connect the keypad to the encoder
- An RS232 cable with 6-way Molex connector to connect the encoder to your controller
- Polarizing pins fitted to the appropriate encoder pins
- A +5V regulated supply
- Prepared your panel fixing
- A 16-way ribbon cable if using the Storm 5000 series bezel with LCD (this cable is not supplied by Storm)

Configuration Switch Settings	1	2	3	4	5	6	7	8
4 Way Keypads	ON	CHARACTER ECHOING SELECTOR ON = ECHO ON OFF = ECHO OFF	OFF	ON	ON	ON	OFF	BAUD RATE SELECTOR OFF=9600 BAUD ON=1200 BAUD
Installation Checklist ✓ Keypad ✓ Encoder, configuration switch set ✓ Panel Fixing prepared ✓ +5V regulated supply ✓ RS 232 cable with 6 way Molex socket ✓ Ribbon cable keypad to encoder if needed ✓ LCD and 16 way ribbon cable if needed ✓ Polarising pins fitted to encoder								

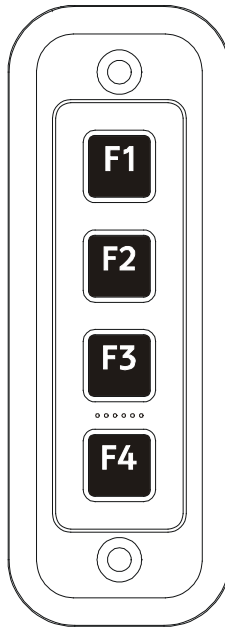
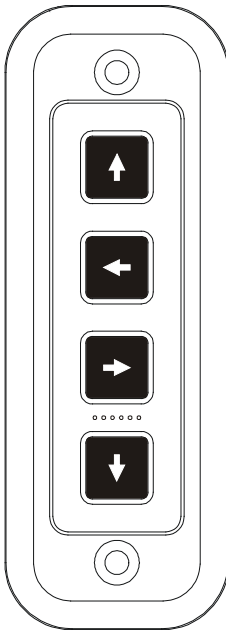

ENCODER PIN	TO	KEYPAD PIN
		Non-illuminated Illuminated
2		NC 1
11		1 2
5		5 6
6		4 5
7		3 4
8		2 3
13		NC 7

4 WAY BACKLIT KEYPAD CONTACT CONNECTIONS (REAR VIEW)

PINS	• • • • • • •
PIN NUMBER	7 6 5 4 3 2 1

CONTACT MATRIX

PIN	ROW / COLUMN
1	LED POWER
2	R5
3	C4
4	C3
5	C2
6	C1
7	LED POWER

ASCII CODES

COLUMN	Row 5
C1	11
C2	12
C3	13
C4	14

4 WAY KEYPAD CONTACT CONNECTIONS (REAR VIEW)

PINS	• • • • •
PIN NUMBER	5 4 3 2 1

CONTACT MATRIX

PIN	ROW / COLUMN
1	R5
2	C4
3	C3
4	C2
5	C1

Connecting the Encoder to a 12 or 16 Way Keypad – Telephone Layout

Storm 12 and 16 way keypads can be connected directly to the encoder with no need for any cables. Before you connect the encoder to a 12 or 16 way keypad, make sure you have:

- An RS232 cable with 6-way Molex connector to connect the encoder to your controller
- Polarizing pins fitted to the appropriate encoder pins
- A +5V regulated supply
- Prepared your panel fixing

Configuration switch settings for the telephone layout keypad:

- 1 & 7 should be in the 'ON' position
- 3, 4, 5 & 6 should be in the 'OFF' position
- 2 controls the character echoing

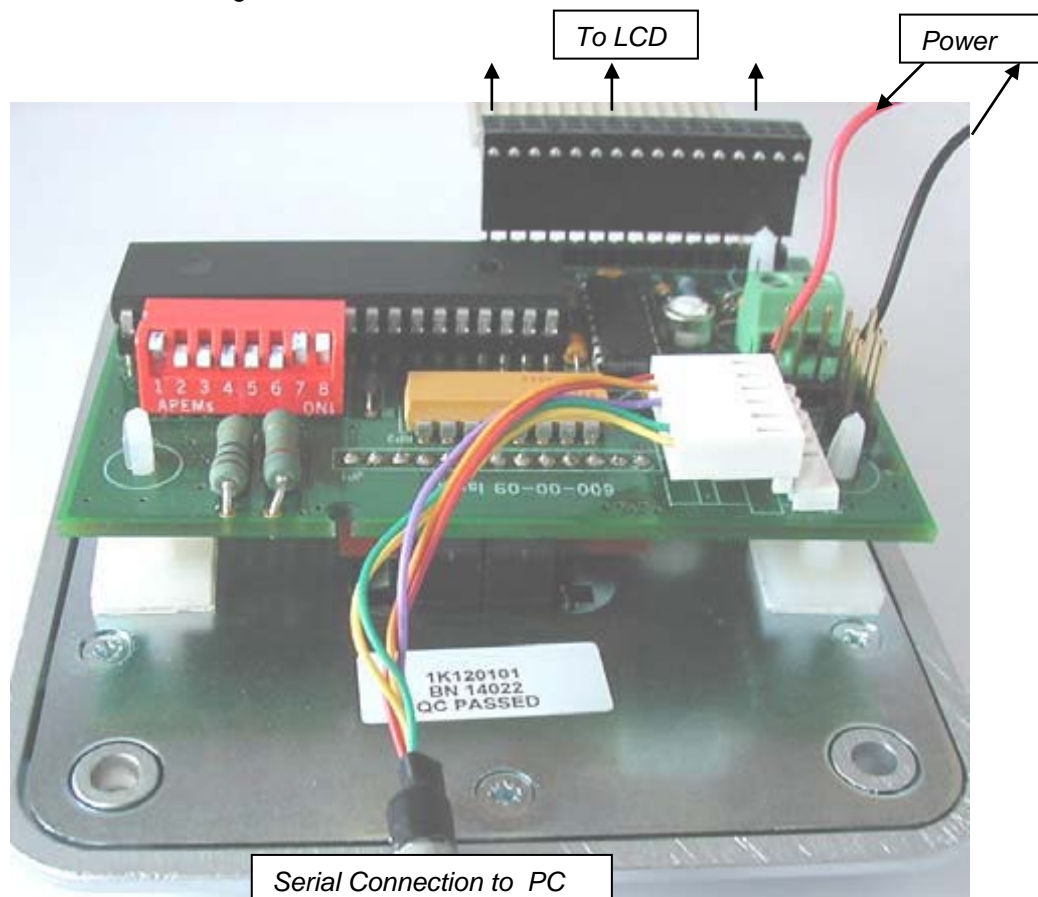

Typical picture showing encoder mounted directly to keypad.

Configuration Switch Settings		1	2	3	4	5	6	7	8	Installation Checklist	
12 and 16 Way Telephone Layout Keypads	ON	CHARACTER ECHOING SELECTOR			OFF	OFF	OFF	OFF	ON		BAUD RATE SELECTOR OFF=9600 BAUD ON=1200 BAUD
		ON = ECHO ON OFF = ECHO OFF									

- Installation Checklist**
- ✓ Keypad
 - ✓ Encoder, configuration switch set
 - ✓ Panel Fixing prepared
 - ✓ +5V regulated supply
 - ✓ RS 232 cable with 6 way Molex socket
 - ✓ Ribbon cable keypad to encoder if needed
 - ✓ LCD and 16 way ribbon cable if needed
 - ✓ Polarising pins fitted to encoder

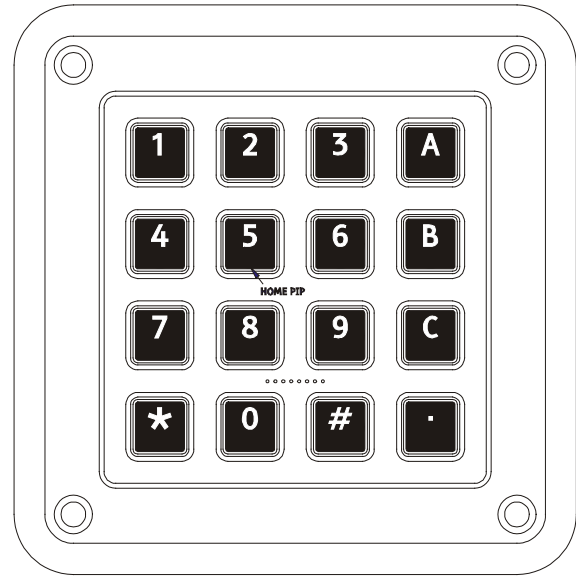
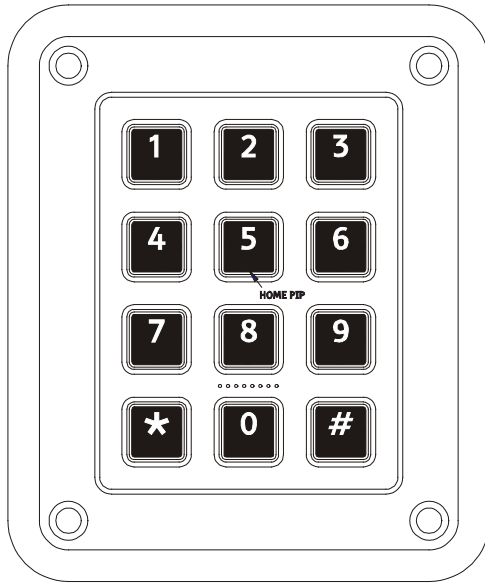

12 / 16 WAY KEYPAD CONTACT CONNECTIONS (REAR VIEW)

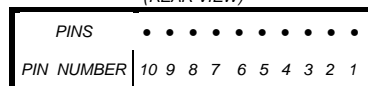

CONTACT MATRIX

PIN	ROW / COLUMN
1	LED POWER
2	R1
3	R2
4	C1
5	C2
6	C3
7	C4 (16 WAY ONLY)
8	R4
9	R3
10	LED POWER

ASCII Codes

ROW / COLUMN	C1	C2	C3	C4
R1	31	32	33	61
R2	34	35	36	62
R3	37	38	39	63
R4	2A	30	23	2E

12 / 16 WAY KEYPAD CONTACT CONNECTIONS (REAR VIEW)

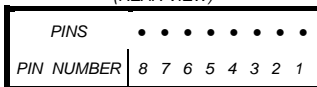

CONTACT MATRIX

PIN	ROW / COLUMN
1	R1
2	R2
3	C1
4	C2
5	C3
6	C4 (16 WAY ONLY)
7	R4
8	R3

Connecting the Encoder to a 12 or 16 Way Keypad – Calculator Layout

Storm 12 and 16 way keypads can be connected directly to the encoder with no need for any cables. Before you connect the encoder to a 12 or 16 way keypad, make sure you have:

- An RS232 cable with 6-way Molex connector to connect the encoder to your controller
- Polarizing pins fitted to the appropriate encoder pins
- A +5V regulated supply
- Prepared your panel fixing

Configuration switch settings for the calculator layout keypad:

- 1, 4 & 7 should be in the 'ON' position.
- 3, 5 & 6 should be in the 'OFF' position .
- 2 controls the character echoing.
- 8 controls the Baud rate selector.

Configuration Switch Settings		1	2	3	4	5	6	7	8	Installation Checklist	
			CHARACTER ECHOING SELECTOR						BAUD RATE SELECTOR		<ul style="list-style-type: none"> ✓ Keypad ✓ Encoder , configuration switch set ✓ Panel Fixing prepared ✓ +5V regulated supply ✓ RS 232 cable with 6 way Molex socket ✓ Ribbon cable keypad to encoder if needed ✓ LCD and 16 way ribbon cable if needed ✓ Polarising pins fitted to encoder
12 and 16 Key Calculator Layout Keypads	ON	ON = ECHO ON	OFF	ON	OFF	OFF	ON	OFF=9600 BAUD			
		OFF = ECHO OFF						ON=1200 BAUD			

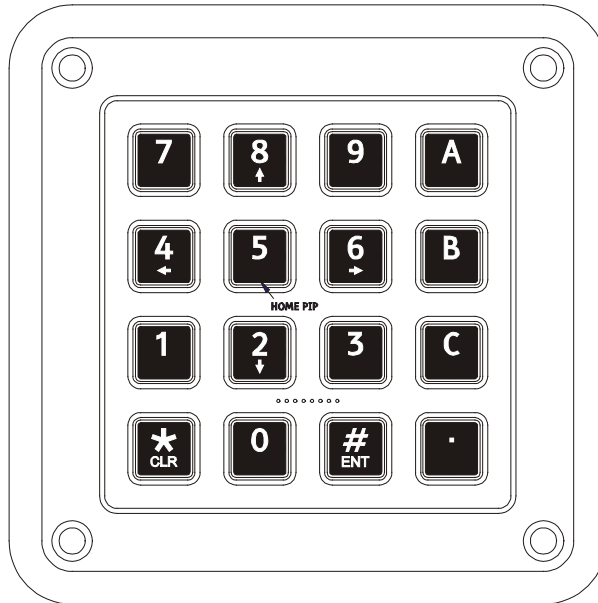
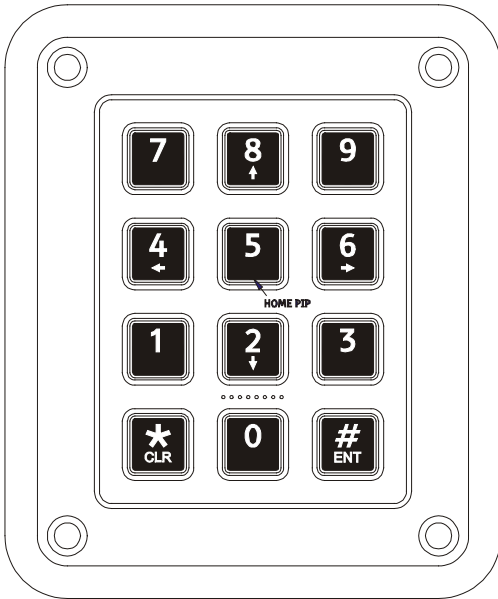

12 / 16 WAY KEYPAD CONTACT CONNECTIONS (REAR VIEW)

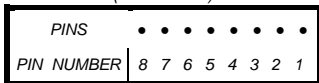

CONTACT MATRIX

PIN	ROW / COLUMN
1	R1
2	R2
3	C1
4	C2
5	C3
6	C4 (16 WAY ONLY)
7	R4
8	R3

12 / 16 WAY KEYPAD CONTACT CONNECTIONS (REAR VIEW)

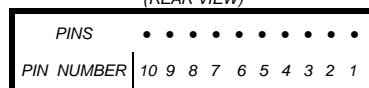

CONTACT MATRIX

PIN	ROW / COLUMN
1	LED POWER
2	R1
3	R2
4	C1
5	C2
6	C3
7	C4 (16 WAY ONLY)
8	R4
9	R3
10	LED POWER

ASCII Codes

ROW/ COLUMN	C1	C2	C3	C4
R1	37	38	39	1B
R2	34	35	36	0C*
R3	31	32	33	05
R4	7F	30	0D	2E

Connecting the Encoder to the Storm 5000 Series Integrated Keypad

The Storm 5000 Series Integrated Keypad with LCD can be connected directly to the Storm encoder without the need for a cable.

Before you connect the encoder to any of the Storm 5000 Series keypads, make sure you have:

- An RS232 cable with 6-way Molex connector to connect the encoder to your controller
- The configuration switches set correctly on the encoder
- Polarizing pins fitted to the appropriate encoder pins
- A +5V regulated supply
- Prepared your panel fixing
- Encoder is supplied with four off adhesive backed stand offs. to allow it to be mounted on the back plate.
- 16 way ribbon cable connected between the LCD and encoder. The part number is 4200-101. Not supplied with encoder.



Configuration Switch Settings	1	2	3	4	5	6	7	8	Installation Checklist
Integrated 20 Way Keypad and Display - Telephone Layout	OFF	CHARACTER ECHOING SELECTOR	ON	OFF	OFF	ON	OFF	BAUD RATE SELECTOR	<ul style="list-style-type: none"> ✓ Integrated 20 way Keypad ✓ Encoder , configuration switch set ✓ LCD and 16 way ribbon cable if needed ✓ Panel Fixing prepared ✓ +5V regulated supply ✓ RS 232 cable with 6 way Molex KK socket ✓ Polarisising pins fitted to encoder
Integrated 20 Way Keypad and Display - Calculator Layout	OFF		ON	ON	ON	ON	OFF		
Note : Remove Jumpers from JP3 and JP4 in this configuration.		ON = ECHO ON OFF = ECHO OFF					OFF=9600 BAUD ON=1200 BAUD		

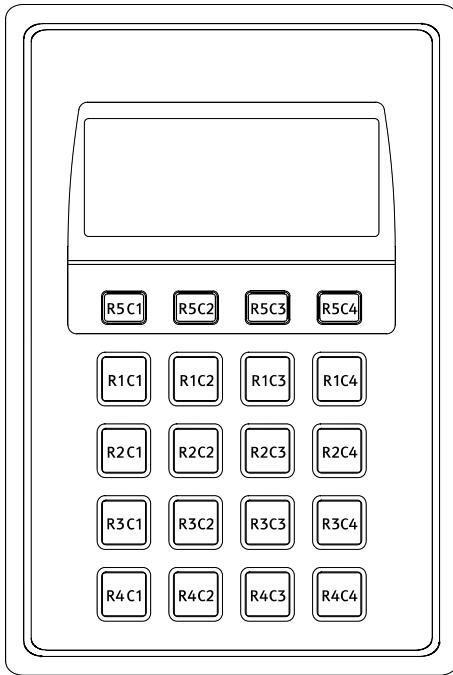

Row / Column	Telephone Layout		Calculator Layout	
	Character	ASCII	Character	ASCII
R5C1	▲	11	▲	11
R5C2	▲	12	▲	12
R5C3	▲	13	▲	13
R5C4	▲	14	▲	14
R1C1	1	31	1	31
R1C2	2 ABC	32	2	32
R1C3	3 DEF	33	3	33
R1C4	A	41	ENTER	1B
R2C1	4 GHI	34	4	34
R2C2	5 JKL	35	5	35
R2C3	6 MNO	36	6	36
R2C4	B	42	CLEAR	0C
R3C1	7 PQRS	37	7	37
R3C2	8 TUV	38	8	38
R3C3	9 WXYZ	39	9	39
R3C4	C	43	?	05
R4C1	* CLR	2A	*	7F
R4C2	0	30	0	30
R4C3	# ENT	23	#	0D
.	ENTER	2E	CANCEL	2E
ANTI-TAMPER OPEN CIRCUIT		07*		07*
* = CODE REPEATS EVERY 10 SECONDS WHILST CONDITION REMAINS ACTIVE				

20 WAY KEYPAD CONTACT CONNECTIONS (REAR VIEW)

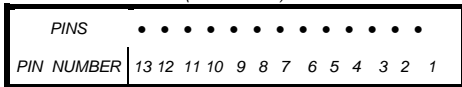

CONTACT MATRIX

PIN	ROW / COLUMN
1	NOT USED
2	TAMPER IN
3	R1
4	R2
5	C1
6	C2
7	C3
8	C4
9	R4
10	R3
11	R5
12	TAMPER OUT
13	NOT USED

Connecting the Encoder to Storm 6000 Keypads

*Each of the Storm 6000 Series keypads are directly connected to the Storm
Before you connect the encoder to the 6000 Series keypad, make sure you have:*

- An RS232 cable with 6-way Molex connector to connect the encoder to your controller
- The configuration switches set correctly on the encoder
- Polarizing pins fitted to the appropriate encoder pins
- A +5V regulated supply
- Prepared your panel fixing

Configuration switch settings for the UK layout keypad:

- Jumper R3 should be removed before use
- 1, 4, 6 & 7 should be in the 'OFF' position
- 3, & 5 should be in the 'ON' position
- 2 controls the character echoing
- 8 controls the Baud. 'OFF' provides a Baud of 9600, 'ON' provides a Baud of 1200.

Configuration switch settings for the USA layout keypad:

- Jumper R3 should be removed before use
- 1, 6 & 7 should be in the 'OFF' position
- 3, 4 & 5 should be in the 'ON' position
- 2 controls the character echoing
- 8 controls the Baud. 'OFF' provides a Baud of 9600, 'ON' provides a Baud of 1200.

Configuration Switch Settings		R3	1	2	3	4	5	6	7	8	Installation Checklist
6000 Series Pinpad - UK Layout	Remove before use	OFF	CHARACTER ECHOING SELECTOR	ON	OFF	ON	OFF	OFF	OFF	BAUD RATE SELECTOR	
6000 Series Pinpad - USA Layout	Remove before use	OFF		ON	ON	ON	OFF	OFF			
			ON = ECHO ON						OFF=9600 BAUD		
			OFF = ECHO OFF						ON=1200 BAUD		

- ✓ Keypad
- ✓ Encoder, configuration switch set
- ✓ Panel Fixing prepared
- ✓ +5V regulated supply
- ✓ RS 232 cable with 6 way Molex KK socket
- ✓ Polarising pins fitted to encoder

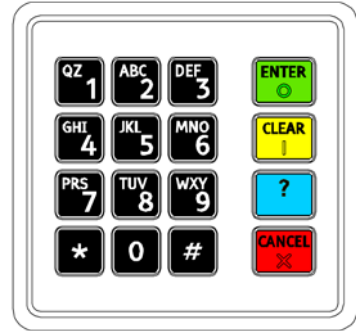
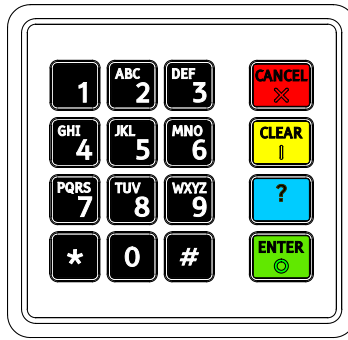
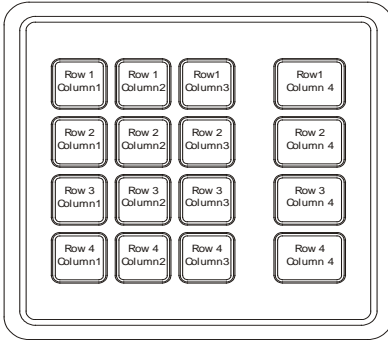

CONTACT CONNECTIONS (REAR VIEW)



CONTACT MATRIX

PIN	ROW / COLUMN
1	NOT USED
2	TAMPER
3	R1
4	R2
5	C1
6	C2
7	C3
8	C4
9	R4
10	R3
11	NC
12	TAMPER
13	NOT USED

ANTI-TAMPER CIRCUIT CONTACT

OPERATING VOLTAGE 24V dc (max)
 OPERATING CURRENT 10mA (max)
 CIRCUIT RESISTANCE <500 Ohms
 (normally closed)

Row / Column	UK Layout			USA Layout		
	Key Legend	Key	ASCII	Key Legend	Key	ASCII
R1C1	1	Black	31	1 QZ	Black	31
R1C2	2 ABC	Black	32	2 ABC	Black	32
R1C3	3 DEF	Black	33	3 DEF	Black	33
R1C4	CANCEL	Red with raised Cross	0D	ENTER	Green with raised circle	1B
R2C1	4 GHI	Black	34	4 GHI	Black	34
R2C2	5 JKL	Black with Homepip	35	5 JKL	Black with Homepip	35
R2C3	6 MNO	Black	36	6 MNO	Black	36
R2C4	CLEAR	Yellow with raised vertical line	7F	CLEAR	Yellow with raised vertical line	7F
R3C1	7 PQRS	Black	37	7 PRS	Black	37
R3C2	8 TUV	Black	38	8 TUV	Black	38
R3C3	9 WXYZ	Black	39	9 WXY	Black	39
R3C4	?	Blue	05	?	Blue	05
R4C1	*	Black	2A	*	Black	2A
R4C2	0	Black	30	0	Black	30
R4C3	#	Black	23	#	Black	23
R4C4	ENTER	Green with raised circle	1B	CANCEL	Red with raised Cross	0D
ANTI-TAMPER OPEN CIRCUIT			07*			07*

*= CODE REPEATS EVERY 10 SECONDS WHILST CONDITION REMAINS ACTIVE. TO RESET—DISCONNECT POWER FOR 30 SECONDS.

LCD Character Map PC 2004LRU Display

Higher 4bit Lower 4bit	0000	0010	0011	0100	0101	0110	0111	1010	1011	1100	1101	1110	1111
xxxx0000		0	1	2	3	4	5	6	7	8	9	A	B
xxxx0001		!	@"	#	\$	%	&	'	()	*	+	,
xxxx0010		"	#	\$	%	&	'	()	*	+	,	;
xxxx0011		4	5	6	7	8	9	:	;	<	=	>	?@
xxxx0100		*	4	5	6	7	8	:	;	<	=	>	?@
xxxx0101		%	6	7	8	9	:	;	<	=	>	?@	AB
xxxx0110		&	7	8	9	:	;	<	=	>	?@	AB	CD
xxxx0111		'	8	9	:	;	<	=	>	?@	AB	CD	EF
xxxx1000		()	*	+	,	;	<	=	>	?@	AB	CD
xxxx1001)	*	+	,	;	<	=	>	?@	AB	CD	EF
xxxx1010		*	+	,	;	<	=	>	?@	AB	CD	EF	GH
xxxx1011		+	,	;	<	=	>	?@	AB	CD	EF	GH	IJ
xxxx1100		,	;	<	=	>	?@	AB	CD	EF	GH	IJ	KL
xxxx1101		;	<	=	>	?@	AB	CD	EF	GH	IJ	KL	MN
xxxx1110		<	=	>	?@	AB	CD	EF	GH	IJ	KL	MN	OP
xxxx1111		=	>	?@	AB	CD	EF	GH	IJ	KL	MN	OP	QR