

Full Metal Hoods

DTSL-T-LJS-RG+High Density D-Sub Solder Cup

TECHNICAL SPECIFICATIONS

D-Sub Hood:

Material: Zinc, Nickel Plated
 Operating Temperature: -40°C to +120°C
 Cable Entry: Top Entry
 Rubber Grommet RGS
 Strain relief: Clamp + Insert
 Thumbscrews: **Long Jackscrews**
 UNC 4-40 (Standard)
 Cable O.D: Up to 11.5mm

High Density D-Sub Solder Cup:

Insulator: Glass filled TP, UL94 V-0
 Shell: Steel, Tin Plated
 Contact pins: Copper Alloy
 Stamped & Formed Pins: Class 3, 100 inserts min.
 Contact Plating: Gold flash over Nickel
 Operating Temperature: -55°C to +85°C
 Withstanding voltage: >1000V Rms to 50 Hz
 for 1 minute
 Current Rating: 3A
 Insulator resistance: >5000MΩ min.

Features:

- Available in Sizes HD15-26-44-62
- Long Jackscrews
- 360° EMI Shielding
- Quick assembly
- Pre-mounted locking screws

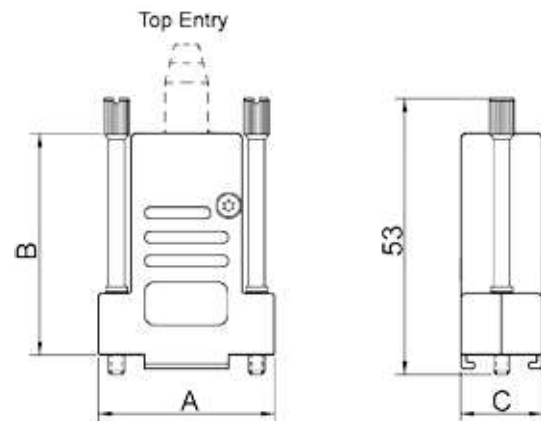

Size DTSL	Dim A	Dim B	Dim C
9-way	32,2	42,0	15,0
15-way	40,8	42,3	15,0
25-way	54,0	42,3	15,0
37-way	70,5	48,0	15,0

Ordering information:

High Density D-Sub Connector Kits

Size:	P/N - Kitted:	Description:
HD 15	L17DTSL09-LJS-RG-T+L717HDE15P	Solder Cup, 15-Male
HD 26	L17DTSL15-LJS-RG-T+L717HDA26P	Solder Cup, 26-Male
HD 44	L17DTSL25-LJS-RG-T+L717HDB44P	Solder Cup, 44-Male
HD 62	L17DTSL37-LJS-RG-T+L717HDC62P	Solder Cup, 62-Male

Size:	P/N - Kitted:	Description:
HD 15	L17DTSL09-LJS-RG-T+L77HDE15S	Solder Cup, 15-Female
HD 26	L17DTSL15-LJS-RG-T+L77HDA26S	Solder Cup, 26-Female
HD 44	L17DTSL25-LJS-RG-T+L77HDB44S	Solder Cup, 44-Female
HD 62	L17DTSL37-LJS-RG-T+L77HDC62S	Solder Cup, 62-Female