

ELECTRICAL SPECIFICATIONS

1. ANTENNA

Parameters	Specification	Unit
Frequency Range	1575.420 ± 1.023	MHz
VSWR, max	2.0	-
Bandwidth, min	10	MHz
Input Impedance	50	Ω
Gain (based on 70x70mm GND plane)	4.5	dBic
Polarization	RHCP	-

2. LNA

Parameters	Specification	Unit
Frequency Range	1575.420 ± 1.023	MHz
Module Stage Line-up	Ant – Fi11 – LNA – Fi12	-
Filter	2 pcs integrated band pass filters	-
DC Voltage	3.0 ~ 5.0	V
Gain	16 ± 2	dB
Outband Rejection, min	F _o + 50MHz	60
	F _o - 50MHz	60
VSWR, max	2.0	-
Noise Figure, max	2.0	dB
DC Current at 3V	6 ± 2	mA

3. Overall (complete module, including RF connector)

Parameters	Specification	Unit
Frequency Range	1575.420 ± 1.023	MHz
VSWR, max	2.0	-
Impedance	50	Ω
RF Connector	SMA Male	-
Cable	RG 174	-
Operating Temperature Range	-40 ~ +85	°C
Storage Temperature Range	-40 ~ +85	°C
Waterproof Grade	IP67	-

Dimensions

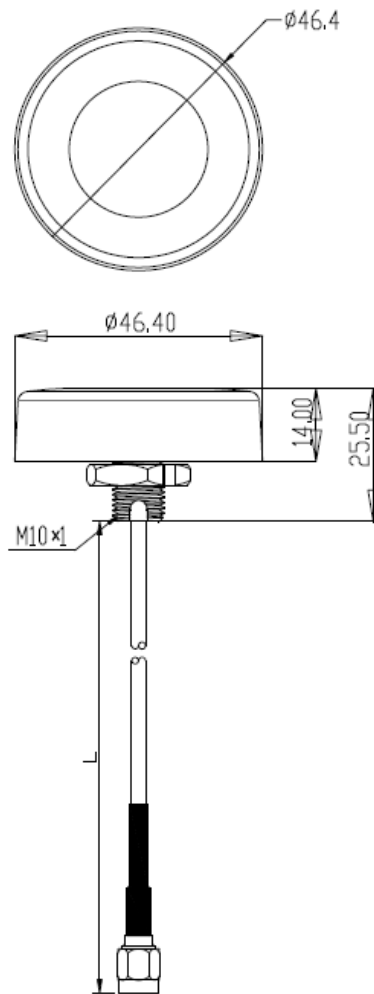

$L = 711 \pm 30$ mm

Schematic Diagram

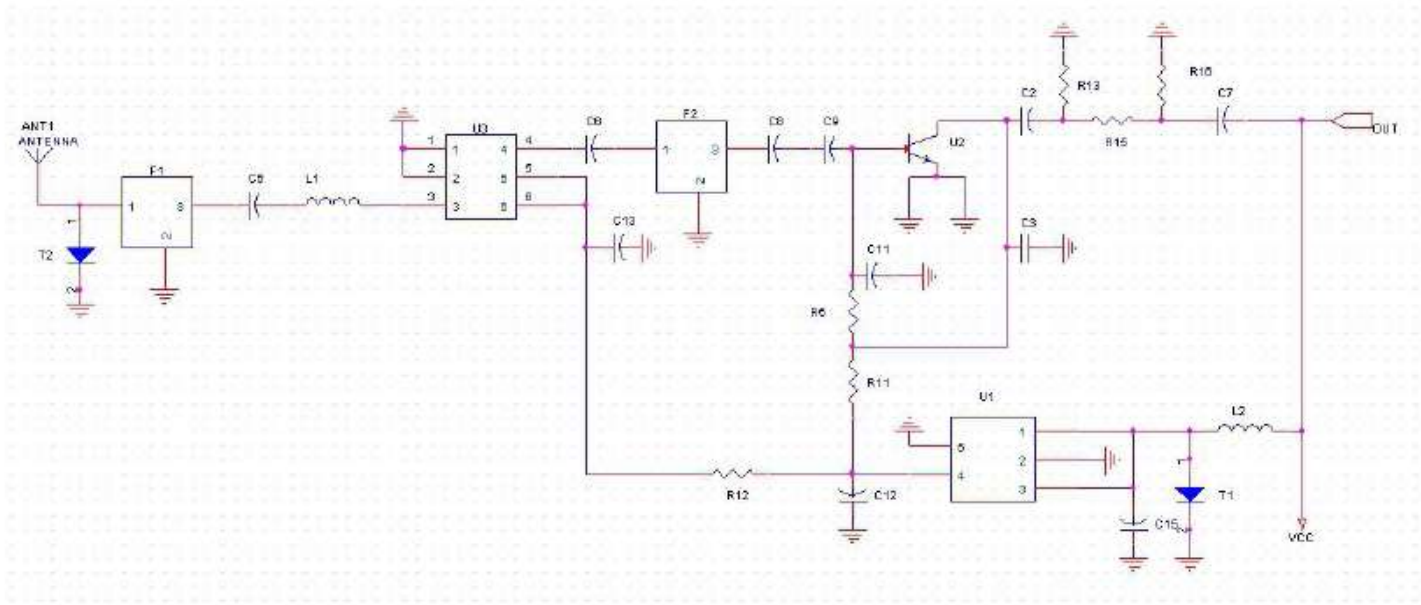

Frequency Characteristics



LNA TEST CURVE (3V)

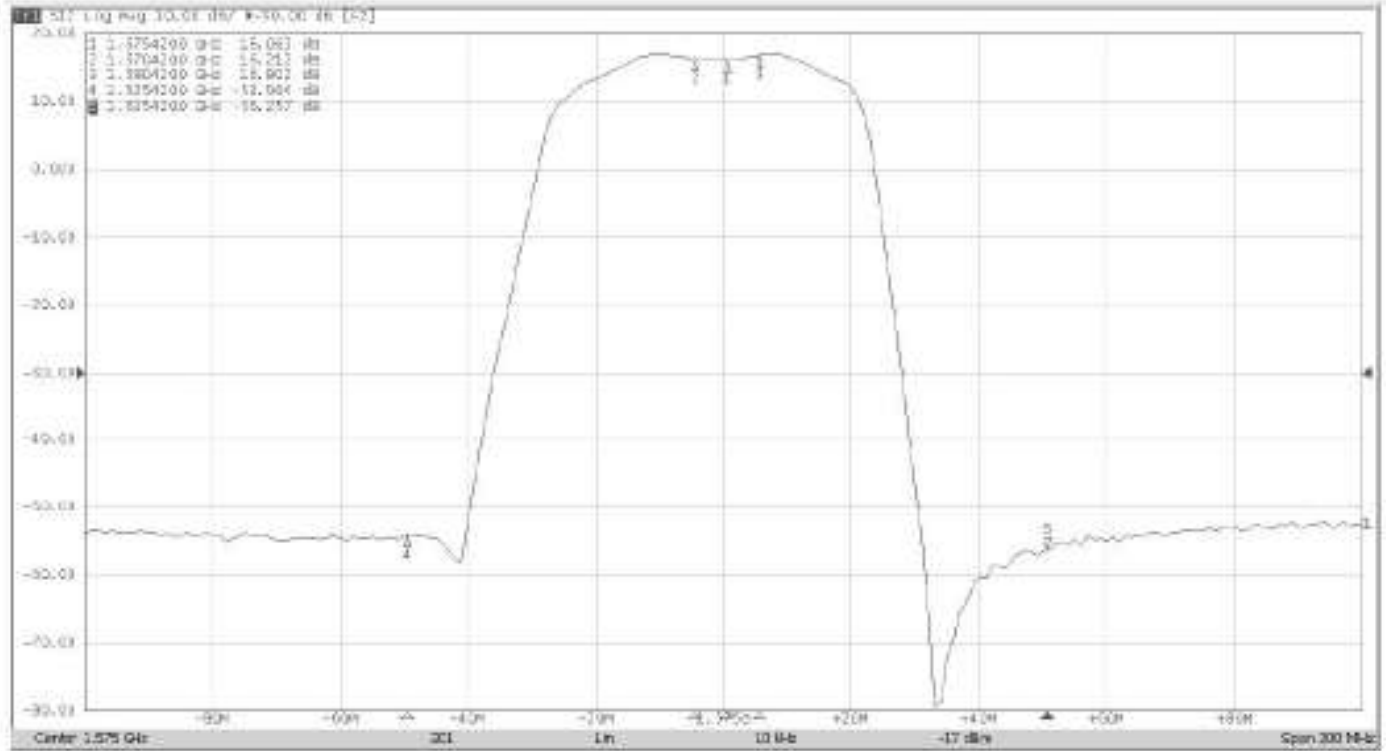

APPROVAL

DRAWN BY	LP, November 04, 2016
APPROVED BY	CP, November 04, 2016
REVISION	A, Initial Release

Raltron Electronics / RAMI Technology USA, LLC, including its affiliates, employees, agents and other persons acting on its behalf (collectively Raltron/RAMI Tech), disclaim any and all liability for any errors or inaccuracies contained in this data sheet. While Raltron/RAMI Tech has made every reasonable effort ensure the accuracy of all product information, specifications and data contained herein, Raltron/RAMI Tech does not guarantee that the information is accurate, reliable or current. The product information is provided only for reference purposes only and is subject to change, correction or revision, at any time without notice. Raltron/RAMI Tech does not assume any liability arising out of an application or use of any product described herein and disclaims any warranties expressed or implied. The user of products in such applications shall assume all risks of such use and will agree to hold Raltron/RAMI Tech, harmless against all damages.

Copyright © 2016, Raltron Electronics / RAMI Technology USA, LLC. All rights reserved. No part of this document may be reproduced in any form without the prior written permission of Raltron Electronics / RAMI Technology USA, LLC.