

HR10 SERIES SHELL SIZE 7mm PUSH-PULL CONNECTORS

Introduction

The HR10 series connectors are push-pull coupling type micro-connectors. They have been developed in response to customers' needs for miniaturization, high density, and easy handling.

The HR10 series connectors offer light weight and assure high reliability and durability as well as easy "push-pull" operation.

You may apply the HR10 series connectors to all kinds of

small-sized electronic equipment requiring high reliability. However, these simple but refined connectors are most suitable for portable electronic equipment which requires good appearance. Typical applications are: Computers and peripherals, medical equipment, audio equipment, video equipment, portable radio (wireless) apparatus, measuring equipment, etc.

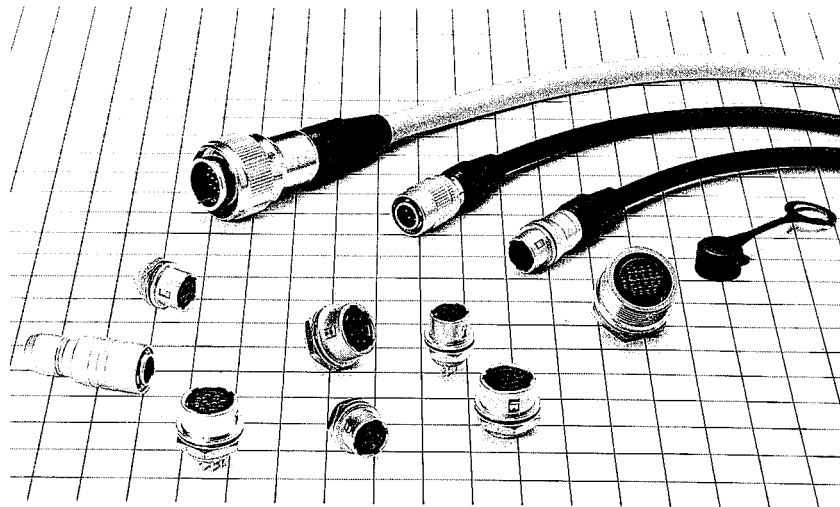

Features

- 1. "A LITTLE GIANT"**
The most compact HR10 series is as slender as a cigarette but it fits every application with well-balanced, simplified layout in limited space.
- 2. EASY "PUSH-PULL" OPERATION**
One touch "push-pull" coupling mechanism assures easy and quick connecting and disconnecting. You can couple it accurately just by pushing any part of the connector housing.
- 3. POLARIZATION**
Five-key system permits only one way of coupling so that you can find right position to connect even when blind mating.
- 4. PROTECTION OF CONNECTION PIN**
A connector pin is located to avoid any damage which may be caused when blind mating.
- 5. HIGH DENSITY**
The space-saving "push-pull" mechanism facilitates multi-installation of connectors.
- 6. EASY WIRING AND MOUNTING**
No use of screws makes wiring and mounting easier.
- 7. SIMPLE AND REFINED APPEARANCE**
Simple and well designed connectors with matte finish enhance the appearance of the equipment.

Material & Finish

Main materials

Part	Material	Finish
Shell	Zinc-alloy and brass	Satin-finished nickel plate
Insulation	Polyamide resin or PBT resin	(Blue or black)
Male terminal	Brass or bronze	Silver- or gold-plated
Female terminal	Beryllium or phosphor bronze	Silver- or gold-plated

Ordering Information

HR10A - 7 P - 4 P A

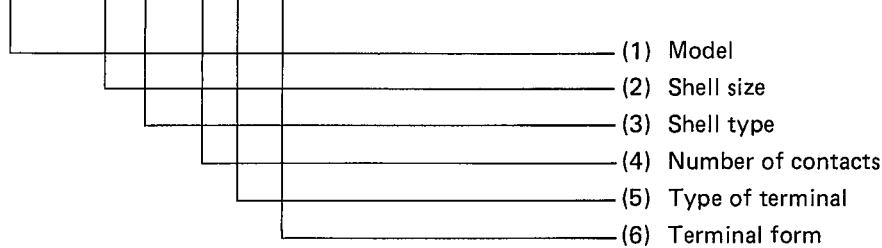

- (1) Model: Denotes HR10 series as follows:
 HR10A: Low-cost model
 HR10G: Shielded
 HR10E: Built-in capacitor
 HR10B: Coaxial terminal
 HR10D: Connector sleeve rotation inhibited
- (2) Shell size: Plug mating part outside diameter in mm.
- (3) Shell type: Indicates the type of shell as follows:
 P: Plug R: Receptacle J: Jack
- (4) Number of contacts: Indicates the number of contacts.
- (5) Type of terminal: Indicates the type of terminal as follows:
 P: Male terminal S: Female terminal
- (6) Terminal form: Indicates terminal connection system in terminal form in alphabetic characters.
 C: Crimp connection system

HR10 type

Gold plating is the standard for the HR10 connector terminals and silver plating is used for the terminals of other types of connectors. When using HR10 connectors combination with other types of connectors, be sure to check the plating specification.

Plug

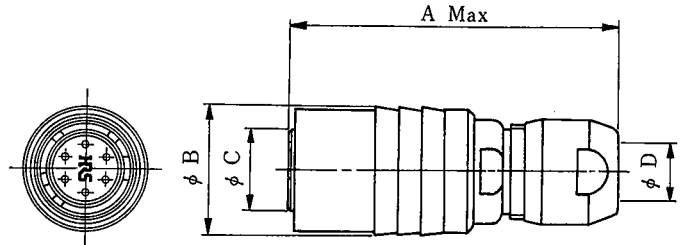
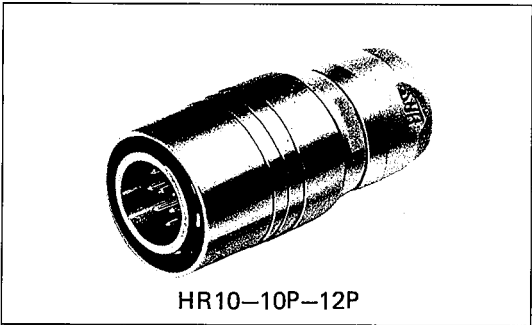
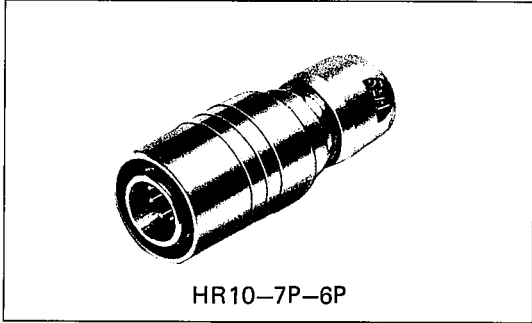

(An example in shape)

HRS No.	Part No.	No. of pins	A	φB	φC	φD	Weight
110-0021-6	HR10- 7P- 4P	4	28.5	11	7	5.2	8g
110-0022-9	HR10- 7P- 4S	4	28.5	11	7	5.2	8g
110-0023-1	HR10- 7P- 6P	6	28.5	11	7	5.2	8g
110-0024-4	HR10- 7P- 6S	6	28.5	11	7	5.2	8g
110-0025-7	HR10-10P-12P	12	32.5	14	9.5	7.2	15g
110-0026-0	HR10-10P-12S	12	32.5	14	9.5	7.2	15g

Receptacle

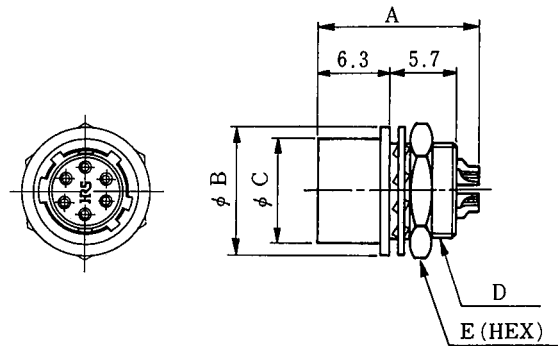
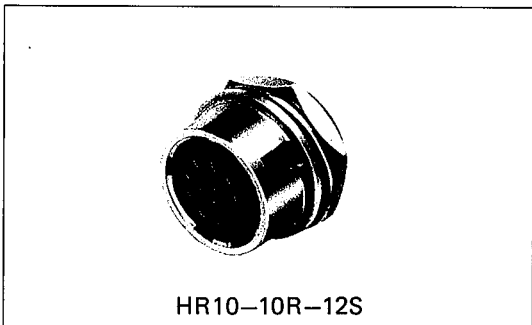
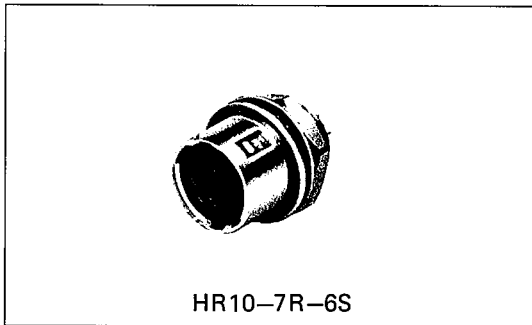

(An example in shape)

HRS No.	Part No.	No. of pins	A	φB	φC	D	E	Weight
110-0031-0	HR10- 7R- 4S	4	14	11	8.85	M8x0.5	10	3.5g
110-0032-2	HR10- 7R- 4P	4	14	11	8.85	M8x0.5	10	3.5g
110-0033-5	HR10- 7R- 6S	6	14	11	8.85	M8x0.5	10	3.5g
110-0034-8	HR10- 7R- 6P	6	14	11	8.85	M8x0.5	10	3.5g
110-0035-0	HR10-10R-12S	12	16	14	11.9	M11x0.75	13	6g
110-0036-3	HR10-10R-12P	12	16	14	11.9	M11x0.75	13	6g

Remark: For mounting holes, see page 85.

Receptacle (PCB Dip Type)

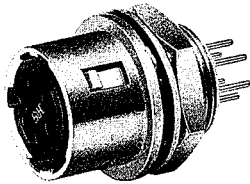

HR10-7R-6SA

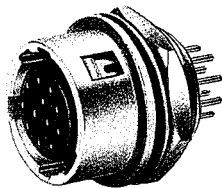

HR10-10R-12SA

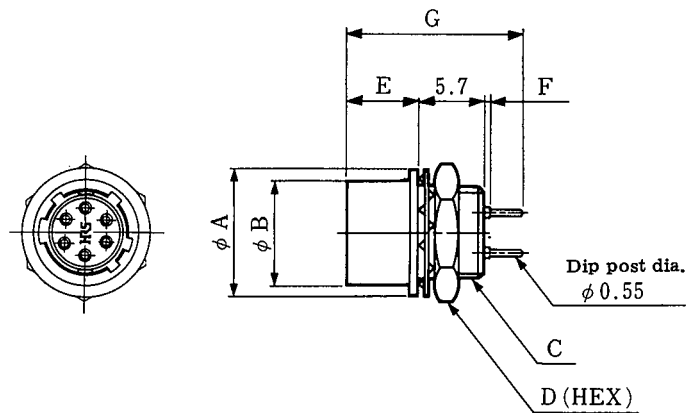

(An example in shape)

HRS No.	Part No.	No. of pins	φA	φB	C	D	E	F	G	Weight
110-0059-9	HR10- 7R- 4SA	4	11	8.85	M8x0.5	10	6.3	0.5	15.5	3g
110-0050-4	HR10- 7R- 6SA	6	11	8.85	M8x0.5	10	6.3	0.5	15.5	3g
110-0061-0	HR10- 7R- 6PA	6	11	8.85	M8x0.5	10	6.3	0.5	15.5	3g
110-0049-5	HR10-10R-12SA	12	14	11.9	M11x0.75	13	6.3	0.5	15.5	5g
110-0055-8	HR10-10R-12PA	12	14	11.9	M11x0.75	13	6.3	0.5	15.5	5g

Remarks: 1. For mounting holes, see page 85.
2. For Dip post arrangement, see page 80.

Jack

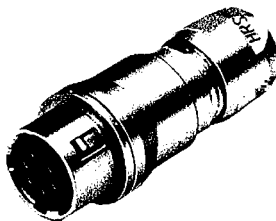

HR10-7J-6S

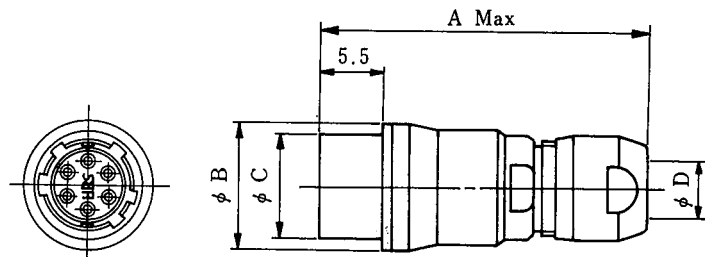

HRS No.	Part No.	No. of pins	A	φB	φC	D	Weight
110-0027-2	HR10- 7J- 4S	4	28.5	11	8.85	5.2	7g
110-0028-5	HR10- 7J- 4P	4	28.5	11	8.85	5.2	7g
110-0029-8	HR10- 7J- 6S	6	28.5	11	8.85	5.2	7g
110-0030-7	HR10- 7J- 6P	6	28.5	11	8.85	5.2	7g
110-0037-6	HR10-10J-12S	12	32.5	14	11.9	7.2	14g
110-0038-9	HR10-10J-12P	12	32.5	14	11.9	7.2	14g

HR10A-10G Type

The model HR10A is a lowcost connector maintaining the excellent characteristics of the HR10 connector while meeting VA requirements. To ensure increased cable-clamping force, the cables are crimped with a special crimping tool, and to increase cable resistance to bending, the shell is covered with a rubber bushing.

The model HR10G is a shielding connector having a built-in contact mechanism with the plug shell inside the receptacle. The standard HR10A and HR10G connector contacts are silver-plated.

Plug (Solder Type)

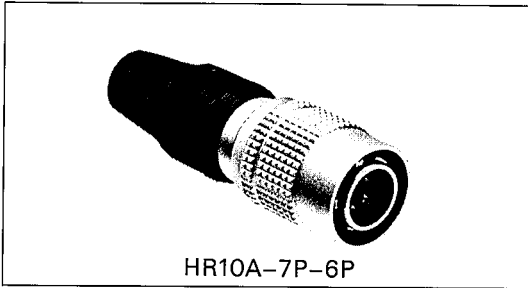

HR10A-7P-6P

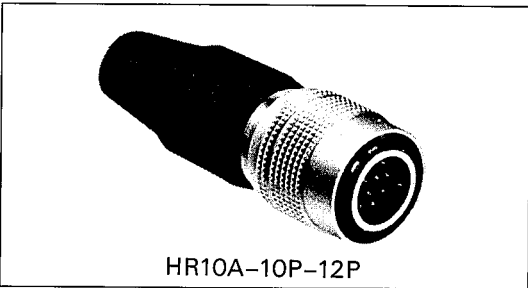

HR10A-10P-12P

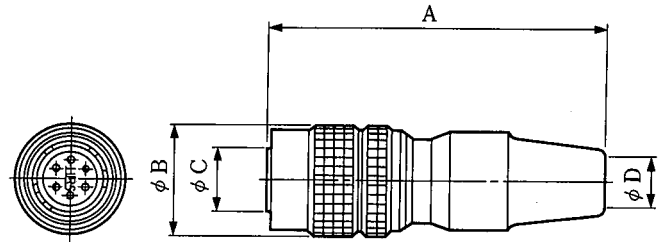

(An example in shape)

HRS No.	Part No.	No. of pins	A	φB	φC	φD	Weight
110-0301-2	HR10A-7P-4P	4	35	11.5	7	5	9g
110-0302-5	HR10A-7P-4S	4	35	11.5	7	5	9g
110-0318-5	HR10A-7P-5P	5	35	11.5	7	5	9g
110-0319-8	HR10A-7P-5S	5	35	11.5	7	5	9g
110-0303-8	HR10A-7P-6P	6	35	11.5	7	5	9g
110-0304-0	HR10A-7P-6S	6	35	11.5	7	5	9g
110-0407-3	HR10A-10P-10P	10	43	14.7	9.5	7	16g
110-0408-6	HR10A-10P-10S	10	43	14.7	9.5	7	16g
110-0401-7	HR10A-10P-12P	12	43	14.7	9.5	7	16g
110-0402-0	HR10A-10P-12S	12	43	14.7	9.5	7	16g
110-0713-0	HR10A-13P-20P	20	58.8	19	13	7	37g
110-0716-8	HR10A-13P-20S	20	58.8	19	13	7	37g

Plug (Crimp Type)

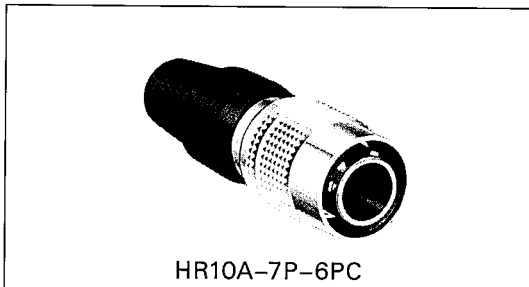

HR10A-7P-6PC

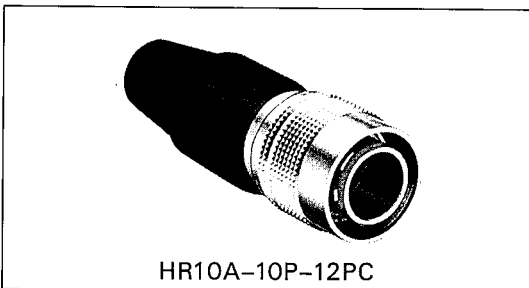

HR10A-10P-12PC

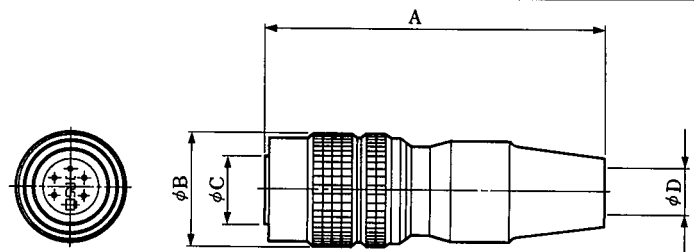

(An example in shape)

HRS No.	Part No.	No. of pins	A	φB	φC	φD	Weight
110-0501-1	HR10A-7P-4PC	4	35	11.5	7	5	9g
110-0502-4	HR10A-7P-4SC	4	35	11.5	7	5	9g
110-0503-7	HR10A-7P-6PC	6	35	11.5	7	5	9g
110-0504-0	HR10A-7P-6SC	6	35	11.5	7	5	9g
110-0601-6	HR10A-10P-10PC	10	43	14.7	9.5	7	16g
110-0602-9	HR10A-10P-10SC	10	43	14.7	9.5	7	16g
110-0603-1	HR10A-10P-12PC	12	43	14.7	9.5	7	16g
110-0604-4	HR10A-10P-12SC	12	43	14.7	9.5	7	16g
110-0701-0	HR10A-13P-20PC	20	58.8	19	13	7	37g
110-0702-3	HR10A-13P-20SC	20	58.8	19	13	7	37g

Receptacle (Solder Type)

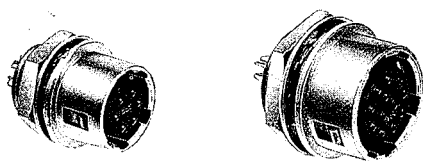

HR10A-7R-6S

HR10G-10R-12S

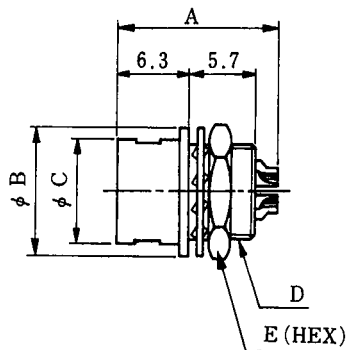
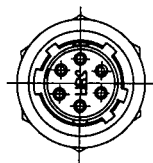

(An example in shape)

HRS No.	Part No.	No. of pins	A	φB	φC	D	E	Weight
110-0305-3	HR10A-7R-4S	4	14	11	8.85	M8x0.5	10	3g
110-0306-6	HR10A-7R-4P	4	14	11	8.85	M8x0.5	10	3g
110-0320-7	HR10A-7R-5S	5	14	11	8.85	M8x0.5	10	3g
110-0321-0	HR10A-7R-5P	5	14	11	8.85	M8x0.5	10	3g
110-0307-9	HR10A-7R-6S	6	14	11	8.85	M8x0.5	10	3g
110-0308-1	HR10A-7R-6P	6	14	11	8.85	M8x0.5	10	3g
110-0409-9	HR10A-10R-10S	10	16	14	11.9	M11x0.75	13	5g
110-0410-8	HR10A-10R-10P	10	16	14	11.9	M11x0.75	13	5g
110-0403-2	HR10A-10R-12S	12	16	14	11.9	M11x0.75	13	5g
110-0404-5	HR10A-10R-12P	12	16	14	11.9	M11x0.75	13	5g
110-0714-2	HR10A-13R-20S	20	19.2	18	15.4	M14x0.75	17	8g
110-0715-5	HR10A-13R-20P	20	20.2	18	15.4	M14x0.75	17	8g

HRS No.	Part No.	No. of pins	A	φB	φC	D	E	Weight	Remarks
110-1601-1	HR10G-7R-4S	4	14	11	8.85	M8x0.5	10	3g	Shield type
110-1602-4	HR10G-7R-4P	4	14	11	8.85	M8x0.5	10	3g	
110-1605-2	HR10G-7R-6S	6	14	11	8.85	M8x0.5	10	3g	
110-1606-5	HR10G-7R-6P	6	14	11	8.85	M8x0.5	10	3g	
110-1607-8	HR10G-10R-10S	10	16	14	11.9	M11x0.75	13	5g	
110-1608-0	HR10G-10R-10P	10	16	14	11.9	M11x0.75	13	5g	
110-1609-3	HR10G-10R-12S	12	16	14	11.9	M11x0.75	13	5g	
110-1610-2	HR10G-10R-12P	12	16	14	11.9	M11x0.75	13	5g	

Remark: For mounting holes, see page 85.

Receptacle (Crimp Type)



HR10A-7R-6SC

HR10G-10R-12SC

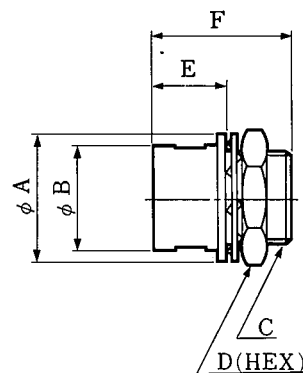

(An example in shape)

HRS No.	Part No.	No. of pins	φA	φB	C	D	E	F	Weight
110-0506-5	HR10A-7R-4SC	4	11	8.85	M8x0.5	10	6.3	12	3g
110-0505-2	HR10A-7R-4PC	4	11	8.85	M8x0.5	10	6.3	12.2	3g
110-0508-0	HR10A-7R-6SC	6	11	8.85	M8x0.5	10	6.3	12	3g
110-0507-8	HR10A-7R-6PC	6	11	8.85	M8x0.5	10	6.3	12.2	3g
110-0606-0	HR10A-10R-10SC	10	14	11.9	M11x0.75	13	6.3	12	5g
110-0605-7	HR10A-10R-10PC	10	14	11.9	M11x0.75	13	6.3	12.2	5g
110-0608-5	HR10A-10R-12SC	12	14	11.9	M11x0.75	13	6.3	12	5g
110-0607-2	HR10A-10R-12PC	12	14	11.9	M11x0.75	13	6.3	12.2	5g
110-0703-6	HR10A-13R-20SC	20	18	15.4	M14x0.75	17	9.3	15	8g
110-0704-9	HR10A-13R-20PC	20	18	15.4	M14x0.75	17	9.3	15	8g

HRS No.	Part No.	No. of pins	φA	φB	C	D	E	F	Weight	Remarks
110-1701-6	HR10G-7R-4SC	4	11	8.85	M8x0.5	10	6.3	12	3g	Shield type
110-1702-9	HR10G-7R-4PC	4	11	8.85	M8x0.5	10	6.3	12.2	3g	
110-1705-7	HR10G-7R-6SC	6	11	8.85	M8x0.5	10	6.3	12	3g	
110-1706-0	HR10G-7R-6PC	6	11	8.85	M8x0.5	10	6.3	12.2	3g	
110-1707-2	HR10G-10R-10SC	10	14	11.9	M11x0.75	13	6.3	12	5g	
110-1708-5	HR10G-10R-10PC	10	14	11.9	M11x0.75	13	6.3	12.2	5g	
110-1709-8	HR10G-10R-12SC	12	14	11.9	M11x0.75	13	6.3	12	5g	
110-1710-7	HR10G-10R-12PC	12	14	11.9	M11x0.75	13	6.3	12.2	5g	
110-1711-0	HR10G-13R-20SC	20	18	15.4	M14x0.75	17	9.3	15	8g	
110-1712-2	HR10G-13R-20PC	20	18	15.4	M14x0.75	17	9.3	15	8g	

Remark: For mounting holes, see page 85.

Receptacle (Dip Type)

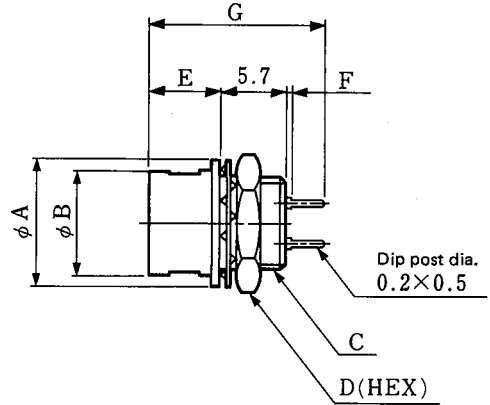
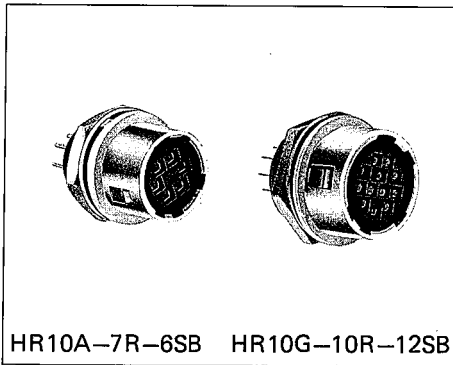

(An example in shape)

HRS No.	Part No.	No. of pins	φA	φB	C	D	E	F	G	Weight	Remarks
110-0314-4	HR10A-7R-4SB	4	11	8.85	M8x0.5	10	6.3	0.5	15.6	3g	
110-0315-7	HR10A-7R-4PB	4	11	8.85	M8x0.5	10	6.3	0.5	15.6	3g	
110-0322-2	HR10A-7R-5SB	5	11	8.85	M8x0.5	10	6.3	0.5	15.6	3g	
110-0316-0	HR10A-7R-6SB	6	11	8.85	M8x0.5	10	6.3	0.5	15.6	3g	
110-0317-2	HR10A-7R-6PB	6	11	8.85	M8x0.5	10	6.3	0.5	15.6	3g	
110-0413-6	HR10A-10R-10SB	10	14	11.9	M11x0.75	13	6.3	0.5	15.6	5g	
110-0414-9	HR10A-10R-10PB	10	14	11.9	M11x0.75	13	6.3	0.5	15.6	5g	
110-0415-1	HR10A-10R-12SB	12	14	11.9	M11x0.75	13	6.3	0.5	15.6	5g	
110-0416-4	HR10A-10R-12PB	12	14	11.9	M11x0.75	13	6.3	0.5	15.6	5g	
110-0707-7	HR10A-13R-20SB	20	18	15.4	M14x0.75	17	9.3	0	17.8	8g	
110-0708-0	HR10A-13R-20PB	20	18	15.4	M14x0.75	17	9.3	0	17.8	8g	
110-1801-0	HR10G-7R-4SB	4	11	8.85	M8x0.5	10	6.3	0.5	15.6	3g	
110-1802-3	HR10G-7R-4PB	4	11	8.85	M8x0.5	10	6.3	0.5	15.6	3g	
110-1805-1	HR10G-7R-6SB	6	11	8.85	M8x0.5	10	6.3	0.5	15.6	3g	
110-1806-4	HR10G-7R-6PB	6	11	8.85	M8x0.5	10	6.3	0.5	15.6	3g	
110-1807-7	HR10G-10R-10SB	10	14	11.9	M11x0.75	13	6.3	0.5	15.6	5g	
110-1808-0	HR10G-10R-10PB	10	14	11.9	M11x0.75	13	6.3	0.5	15.6	5g	
110-1809-2	HR10G-10R-12SB	12	14	11.9	M11x0.75	13	6.3	0.5	15.6	5g	
110-1810-1	HR10G-10R-12PB	12	14	11.9	M11x0.75	13	6.3	0.5	15.6	5g	
110-1811-4	HR10G-13R-20SB	20	18	15.4	M14x0.75	17	9.3	0	17.8	8g	
110-1812-7	HR10G-13R-20PB	20	18	15.4	M14x0.75	17	9.3	0	17.8	8g	

Shield type

Remarks: 1. For mounting holes, see page 85.
2. For dip post arrangement, see page 80.

Dust Cap

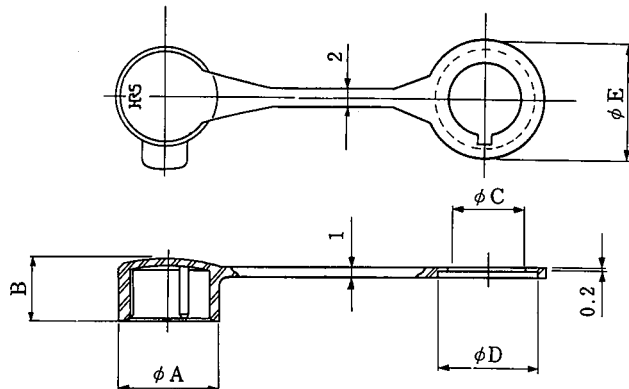
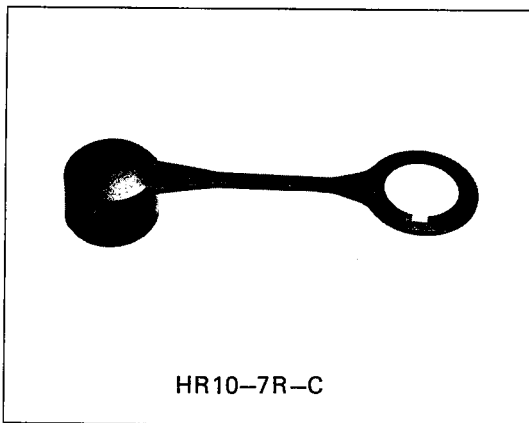

(An example in shape)

HRS No.	Part No.	φA	B	φC	φD	φE
110-0058-6	HR10-7R-C	11	7	8	11.2	13
110-0052-0	HR10-10R-C	14	8.5	10.8	14	15
110-0452-8	HR10A-13R-C	17.5	11.5	14	18.1	19

Jack (Solder Type)

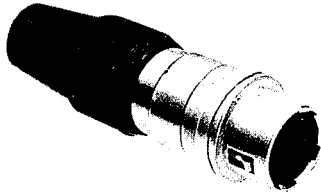

HR10A-7J-6S

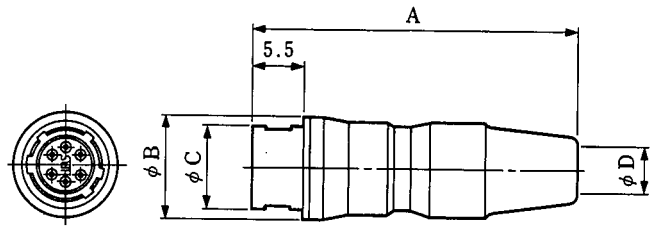

(An example in shape)

HRS No.	Part No.	No. of pins	A	ϕB	ϕC	ϕD	Weight
110-0309-4	HR10A-7J-4S	4	35.3	11	8.85	5	9g
110-0310-3	HR10A-7J-4P	4	35.3	11	8.85	5	9g
110-0311-6	HR10A-7J-6S	6	35.3	11	8.85	5	9g
110-0312-9	HR10A-7J-6P	6	35.3	11	8.85	5	9g
110-0411-0	HR10A-10J-10S	10	43	14	11.9	7	16g
110-0412-3	HR10A-10J-10P	10	43	14	11.9	7	16g
110-0405-8	HR10A-10J-12S	12	43	14	11.9	7	16g
110-0406-0	HR10A-10J-12P	12	43	14	11.9	7	16g

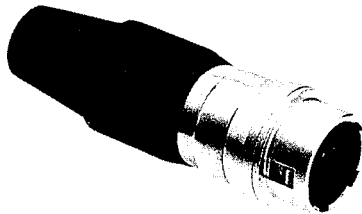

HR10A-10J-12S

Jack (Crimp Type)

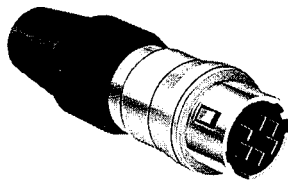

HR10A-7J-6SC

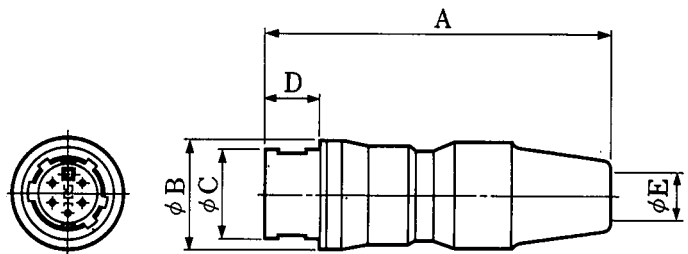

(An example in shape)

HRS No.	Part No.	No. of pins	A	ϕB	ϕC	D	ϕE	Weight
110-0510-2	HR10A-7J-4SC	4	35.3	11	8.85	5.5	5	9g
110-0512-8	HR10A-7J-6SC	6	35.3	11	8.85	5.5	5	9g
110-0610-7	HR10A-10J-10SC	10	43	14	11.9	5.5	7	16g
110-0612-2	HR10A-10J-12SC	12	43	14	11.9	5.5	7	16g
110-0705-1	HR10A-13J-20SC	20	58.5	18	15.4	8.5	7	37g
110-0706-4	HR10A-13J-20PC	20	58.5	18	15.4	8.5	7	37g

HR10B TYPE CONNECTOR

Scope

The HR10B connector combines 10 signal lines and one coaxial contact in the standard number 10 shell. Electrical performance are same as HR10A connector except coaxial

contacts. Performance specifications for the coaxial contacts are on the next page.

Plug

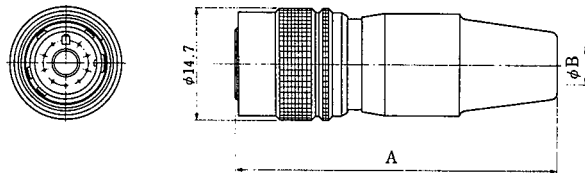
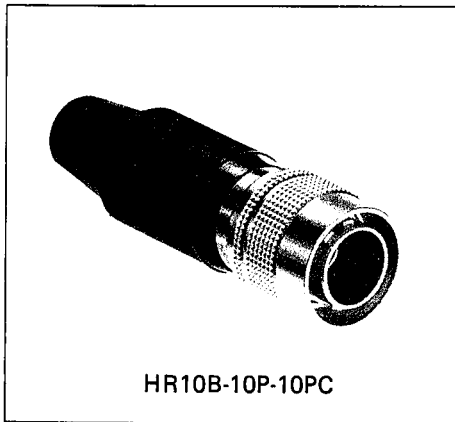

(An example in shape)

HRS No.	Part No.	A	ϕB	Applicable coaxial contact
110-0901-0	HR10B-10P-10PC	50	5	HR10B-2.5CJ
110-0906-3	HR10B-10PA-10PC	43	7	HR10B-2.5CJ

Receptacle

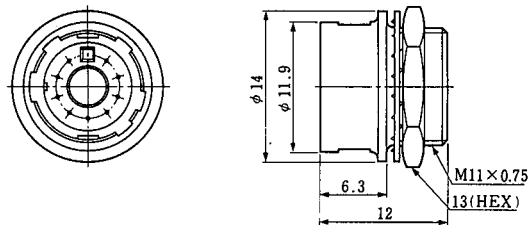
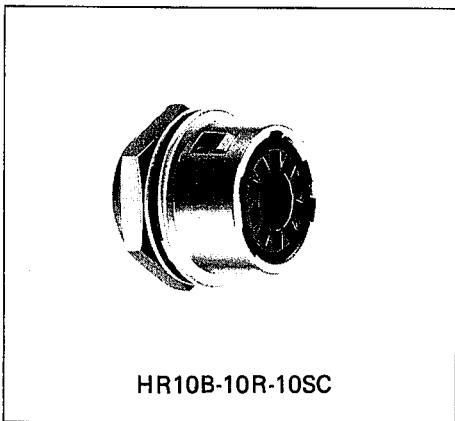

HRS No.	Part No.	Applicable coaxial contact
110-0902-2	HR10B-10R-10SC	HR10B-2.5CP

Remark: For the mounting holes, see page 85.

Coaxial Contacts

The coaxial contacts shown here are for use with the HR10B connector. These contacts have locking bars and are inserted from the rear of the connector. Please use the following information to select the correct terminals.

Material and Finish

Description	Material	Finish
Plug shell	Brass	Gold plate
Jack shell	Brass	Gold plate
Insulator	Tetrafluoride resin	
Male pin	Phosphor bronze	Gold plate
Female pin	Beryllium copper	Gold plate

Performance

Description	Test Data
Impedance	50Ω
Insulation resistance	1000MΩ or more at DC250V
Contact resistance	Center 6.5mΩ or less and outer 4mΩ or less at DC1A
Withstanding voltage	AC250V r.m.s. for 1 minute
V.S.W.R.	1.3 or less for 0 ~ 1000MHz
Pull force	4.9N 500gf or more

Plug

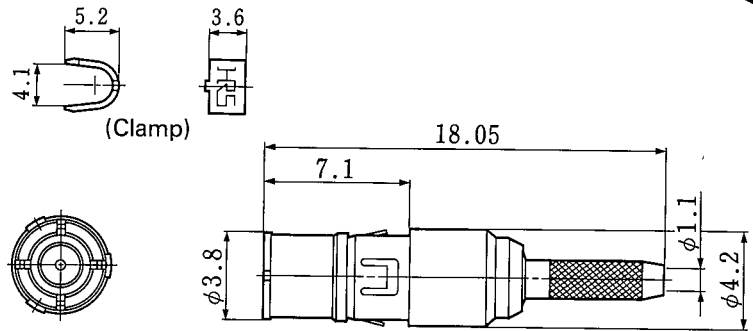
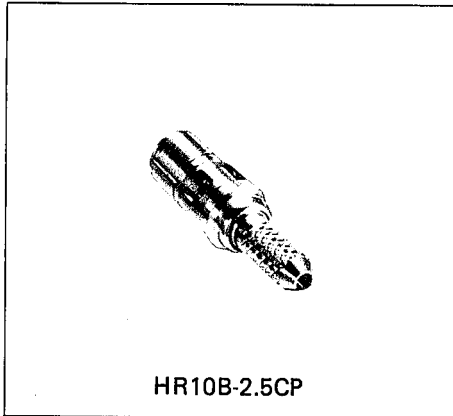

HRS No.	Part No.	Applicable cord	Applicable connector
110-0904-8	HR10B-2.5CP	0.8D-QEW·CW (By Fujikura wire)	HR10B-10R-10SC

Jack

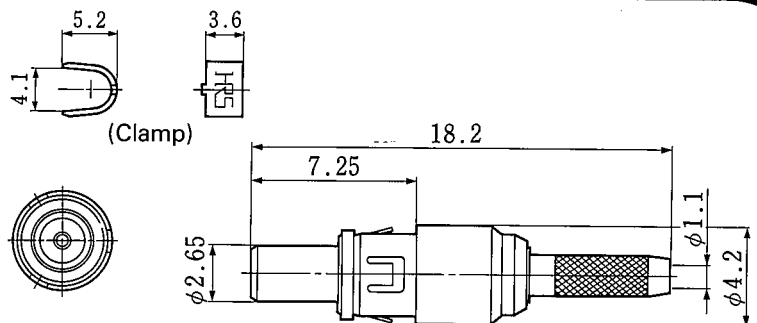
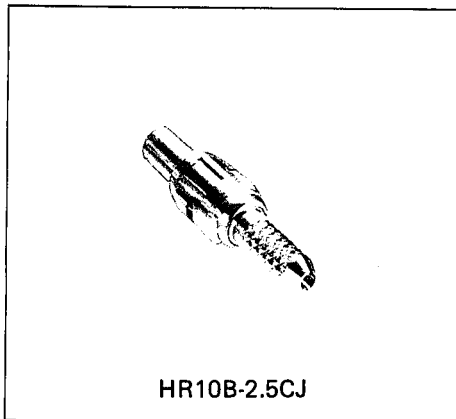

HRS No.	Part No.	Applicable cord	Applicable connector
110-0903-5	HR10B-2.5CJ	0.8D-QEW·CW (By Fujikura wire)	HR10B-10P-10PC

Cable Connecting Methods

HR10B-2.5CP
HR10B-2.5CJ Connecting Methods

PROCESS 1. Cable end treatment

Fig. 1

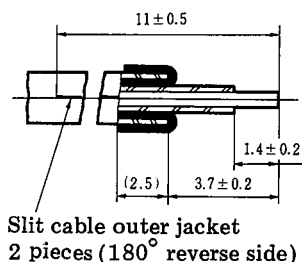

- (1) DIMENSIONS FOR CABLE END TREATMENT ARE SHOWN IN FIG. 1.
- (2) TERMINATION IS DESCRIBED BELOW.
 1. Strip cable outer jacket as indicated.
 2. Slit outer jacket on both sides per Fig. 1.
 3. Fold back outer cover.
 4. Remove insulator from cable.

PROCESS 2. Soldering male pin to cable center conductor

Fig. 2

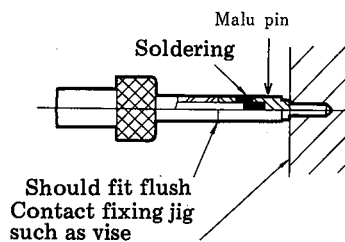

- (1) SOLDER MALE PIN TO CABLE CENTER CONDUCTOR AS INDICATED IN FIG. 2.
 1. Pre-solder the solder pot of male pin with $\phi 0.5\text{mm}$ string solder.
 2. Male pin should fit flush against the cable insulator as shown.
 3. Remove any excess solder from the male pin with a knife. This surface must be smooth.
 4. A properly soldered terminal will yield 500gf when stretched.

PROCESS 3. Crimping cable outer conductor

Fig. 3

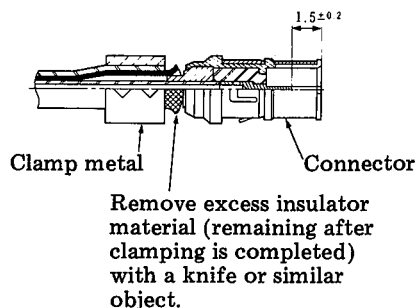

- (1) Insert cable prepared per PROCESS 2 into the connector. The cable should be inserted until it comes to a full stop. This may be verified by checking the dimension from the side of the connector to the top of the male contact (as indicated in Fig. 3). This dimension should be $1.5\text{mm} \pm 0.2$.
- (2) Crimp this installed metal clamp with tool HR10-TC-01 per Fig. 3 and remove excess insulation with a knife.

HR10D TYPE CONNECTOR

Scope

The HR10D connector incorporates a guide key and slot to prevent rotation of the coupling sleeve. A visual mark is used on the sleeve to aid in coupling operations.

Be careful that HR10D connector is not compatible with HR10, HR10A and HR10G.

Plug

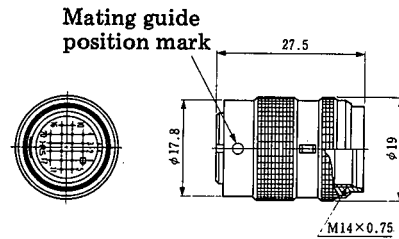
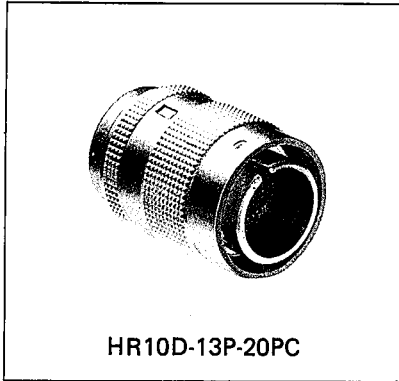

HRS No.	Part No.
110-0801-5	HR10D-13P-20PC

Hood

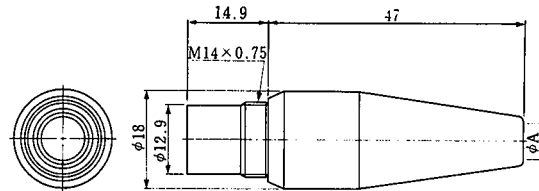
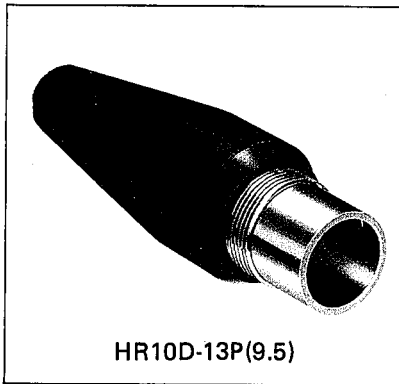

(An example in shape)

HRS No.	Part No.	φA
110-0803-0	HR10D-13P(7)	7
110-0804-3	HR10D-13P(9.5)	9.5

Receptacle (Crimp Type)

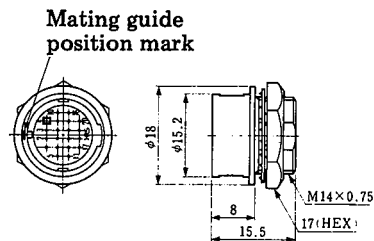

HRS No.	Part No.
110-0802-8	HR10D-13R-20SC

Remark: For the mounting holes, see page 85.

Receptacle (Dip Type)

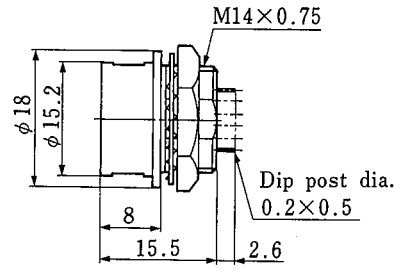
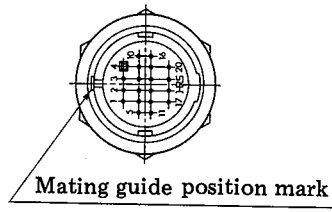
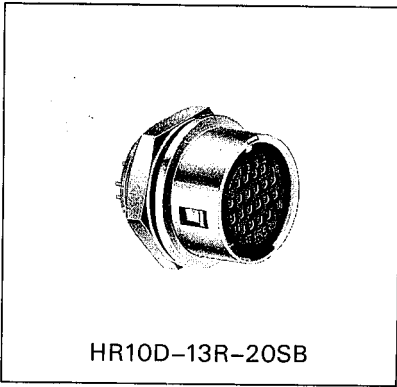

HRS No.	Part No.
110-0805-6	HR10D-13R-20SB

Remarks. 1. For mounting holes. See page 85.
 2. For dip post arrangement see page 80.

HR10A-[] T TYPE (Threaded Coupling Type)

Scope

HR10A-()T connector is a new product having a threaded coupling locking mechanism. Electric performance is same as HR10 and HR10A push-pull locking type connector.

Plug (Solder Type)

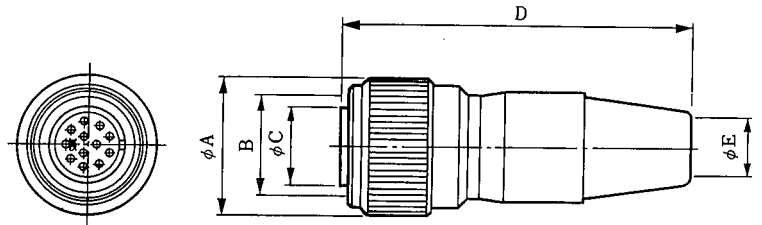
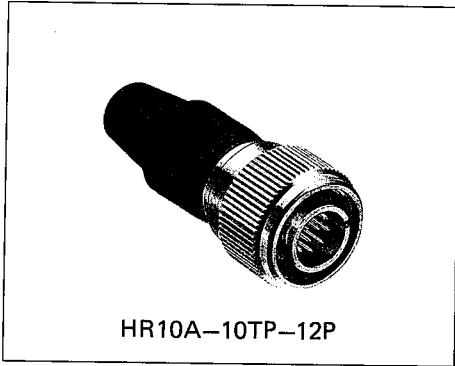

(An example in shape)

HRS No.	Part No.	No. of pins	ϕA	B	ϕC	D	ϕE	Remarks
110-0331-3	HR10A-7TP-6P	6	12	M10x0.75	7	35	5	
110-0331-3-01	HR10A-7TP-6P(01)	6	12	M10x0.75	7	35	5	Gold plated
110-0432-0	HR10A-10TP-12P	12	17	M13x0.75	9.5	43	7	
110-0446-5	HR10A-10TPA-12S	12	17	M13x0.75	9.5	43	7	
110-1101-9	HR10A-10WTP-12P	12	15	M12x0.75	9.5	45.8	6.5	
110-1106-2	HR10A-10WTP-12S	12	15	M12x0.75	9.5	45.8	6.5	
110-1015-9	HR10A-13TPD-20P	20	20	M17x1	13	56.5	7	

Plug (Crimp Type)

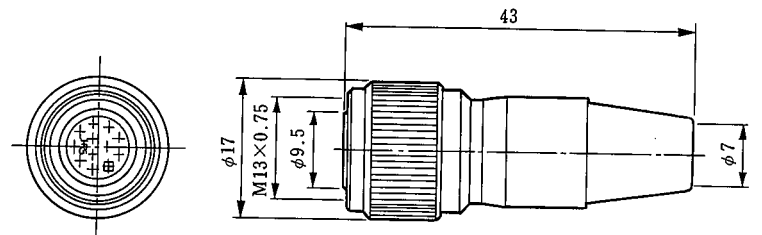

HRS No.	Part No.	No. of pins
110-0455-6	HR10A-10TP-12PC	12

Receptacle (Solder Type)

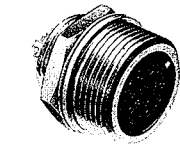

HR10A-10TR-12S

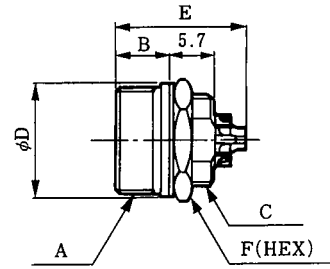
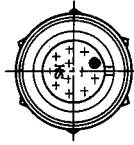

(An example in shape)

HRS No.	Part No.	No. of pins	A	B	C	ϕD	E	F	Remarks
110-0089-0	HR10-7TR-6S	6	M10x0.75	6.3	M8x0.5	11	14	10	Gold plated
110-0453-0	HR10A-10TR-12S	12	M13x0.75	6.3	M11x0.75	14	16	13	
110-1104-7	HR10A-10WTR-12S	12	M12x0.75	6.8	M10.5x0.75	14	16	13	

Remark: For the mounting holes, see page 79. However, 7TR size shall be referred to page 85 on the shell size 7.

Receptacle (Crimp Type)

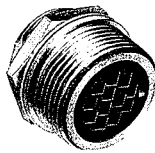

HR10A-10TR-12SC

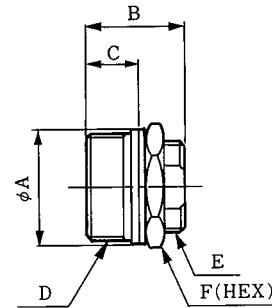
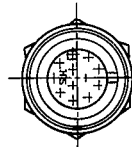

(An example in shape)

HRS No.	Part No.	No. of pins	ϕA	B	C	D	E	F
110-0456-9	HR10A-10TR-12SC	12	14	12	6.3	M13x0.75	M11x0.75	13
110-1002-7	HR10A-13TR-20SC	20	18	15	9.3	M17x1	M14x0.75	17

Remark: For the mounting holes, see page 79.

Receptacle (Dip Type)

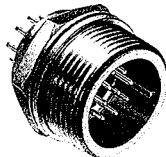

HR10A-10TR-12PB

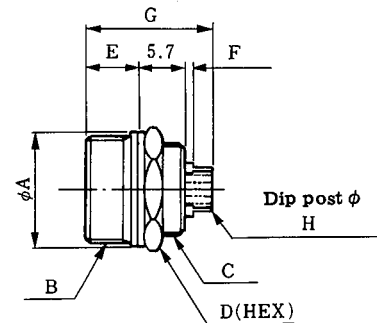
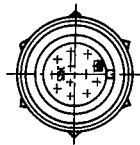

(An example in shape)

HRS No.	Part No.	No. of pins	ϕA	B	C	D	E	F	G	H	Remarks
110-0330-0	HR10A-7TR-6SA	6	11	M10x0.75	M8x0.5	10	6.3	0.5	15.5	0.55 ϕ	
110-0433-3	HR10A-10TR-12SB	12	14	M13x0.75	M11x0.75	13	6.3	0.5	15.5	0.2x0.5	
110-0457-1	HR10A-10TR-12PB	12	14	M13x0.75	M11x0.75	13	6.3	0.5	15.5	0.2x0.5	
110-0445-2	HR10A-10TR-12PE	12	14	M13x0.75	M11x0.75	13	6.3	0.5	14	0.2x0.5	
110-1102-1	HR10A-10WTR-12SB	12	14	M12x0.75	M10.5x0.75	13	6.8	0	15.5	0.2x0.5	
110-1013-3	HR10A-13TR-20PB	20	18	M17x1	M14x0.75	17	9.3	0	17.8	0.2x0.5	
110-1014-6	HR10A-13TR-20SB	20	18	M17x1	M14x0.75	17	9.3	0	17.8	0.2x0.5	

Remarks: 1. For the mounting holes, see page 79. However, 7TR size shall be referred to page 85 on the shell size 7.
2. For dip post arrangement, see page 80.

Jack (Solder Type)

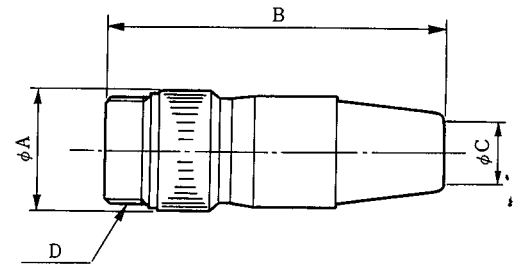
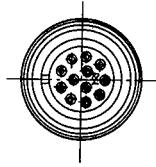
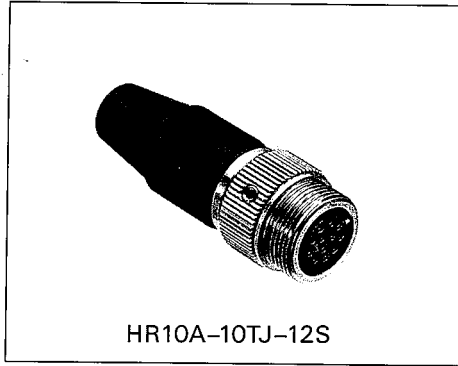

(An example in shape)

HRS No.	part No.	No. of pins	ϕA	B	ϕC	D	Remarks
110-0436-1	HR10A-10TJ-12S	12	14.7	41.3	7	M13x0.75	
110-0459-7	HR10A-10TJ-12P	12	14.7	41.3	7	M13x0.75	
110-1103-4	HR10A-10WTJ-12S	12	14	46.5	6.5	M12x0.75	

Panel mounting hole dimensions(screw coupling)

The mounting hole dimensions shown below are for connectors to be tightened by a hexagonal nut from the back of the panel. The dimensions below apply only to the HR10A-[]T and not the 7TR. For the dimensions of connectors of other types, see page 85.

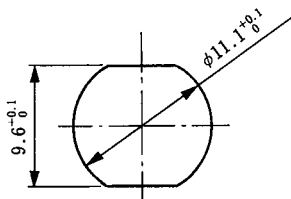

Type HR10A-10TR
(Panel thickness 1 to 2mm)

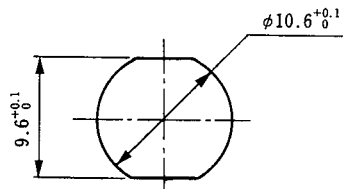

Type HR10A-10WTR
(Panel thickness 1 to 2mm)

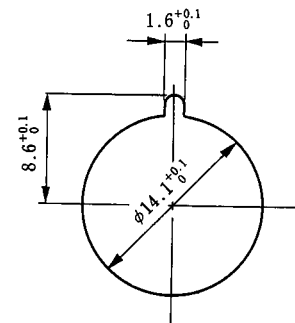

Type HR10A-13TR
(Panel thickness 1 to 1.5mm)

Contact

Male Pin

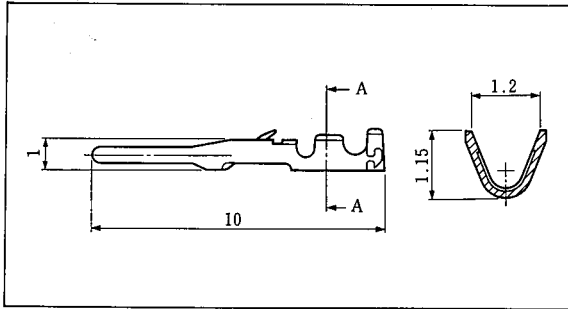

Type	HRS No.	Part No.	Type of plating	Applicable wire
Loose contact	110-0515-6	HR10-PC-111	Partial gold plating	AWG#26~#30
	110-0513-0	HR10-PC-112	Silver plating	AWG#26~#30
Chain contact	110-0516-9	HR10-PC-211	Partial gold plating	AWG#26~#30
	110-0514-3	HR10-PC-212	Silver plating	AWG#26~#30

Remarks: 1. Use cables with a coating outside diameter of 1mm or less.
2. Loose-piece terminal are available in packs. Each pack contains 100 terminals. Strip terminals are available in reels. Each reel contains 10,000 terminals.

Female Pin

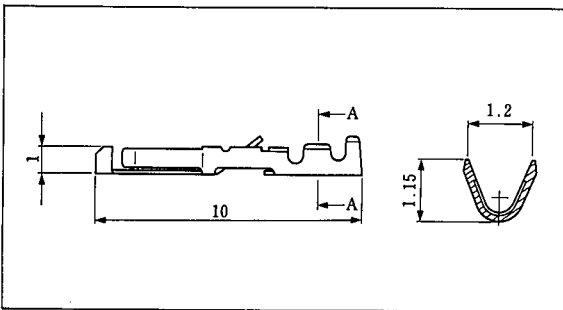

Type	HRS No.	Part No.	Type of plating	Applicable wire
Loose contact	112-0410-0	HR12-SC-111	Partial gold plating	AWG#26~#30
	112-0411-3	HR12-SC-112	Silver plating	AWG#26~#30
Chain contact	112-0407-6	HR12-SC-211	Partial gold plating	AWG#26~#30
	112-0408-9	HR12-SC-212	Silver plating	AWG#26~#30

Remarks: 1. Use cables with a coating outside diameter of 1mm or less.
2. Loose-piece terminal are available in packs. Each pack contains 100 terminals. Strip terminals are available in reels. Each reel contains 10,000 terminals.

Receptacle dip post arrangement dimensions

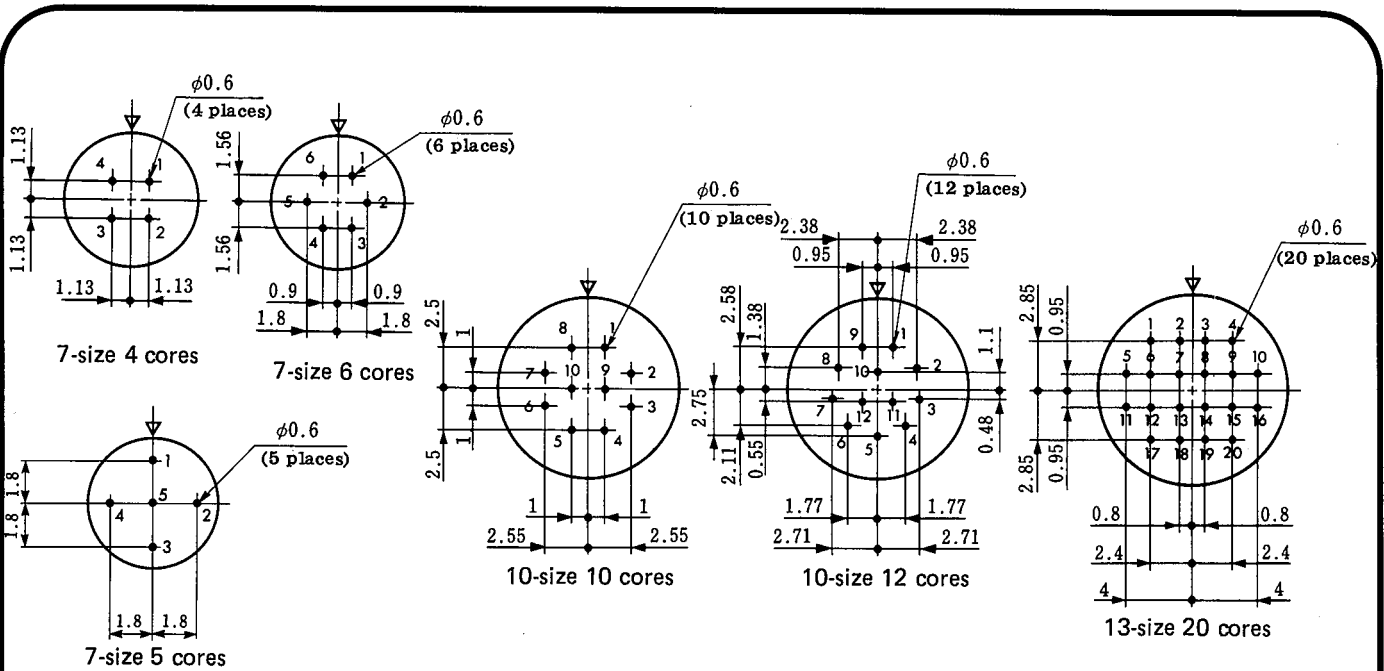

Remarks: 1. The above figures are views of receptacle-socket inserts from the mating side and plug-pin inserts from the wiring-connection side.
2. Dimensional tolerance of ± 0.05 is recommended for the board arrangement.

Tools

Type	Item	HRS No.	Part No.	Applicable terminal	Applicable wire and Applicable Cable diameter
Manual	Manual crimping tool	150-0052-9	HR12-SC-TC	HR10-PC-112	AWG # 26~ # 30
				HR12-SC-112	
Automatic	Automatic crimping machine body	901-0005-4	CM-105	—	—
	Applicator	901-2015-9	AP105-HR12-1	HR10-PC-211 212 213	AWG # 26~ # 30
				HR12-SC-211 212 213	
Cable crimping tool		150-0036-2	HR10-TC-01	—	(HR10B-2.5CP, HR10B-2.5CJ)
		150-0041-2	HR10A-TC-02		$\phi 7, \phi 5$
		150-0055-7	HR10D-TC-02		$\phi 9.5$
Extractor		150-0050-3	HR12-SC-TP	HR12-SC-112	—
				HR12-SC-212	
		150-0039-0	RP6-SC-TP	HR10-PC-112	
				HR10-PC-212	
		150-0061-0	HR10B-TP	HR10B-2.5CP	
				HR10B-2.5CJ	

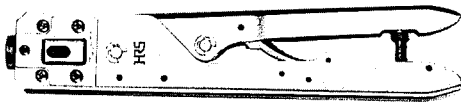

(HR12-SC-TC)
Hand Crimp Tool



(HR12-SC-TP)

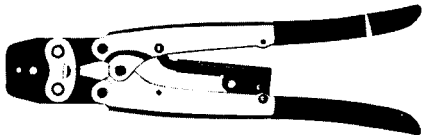

(HR10A-TC-02)
Hand Cable Crimp Tool



(RP6-SC-TP)
Extraction Tool

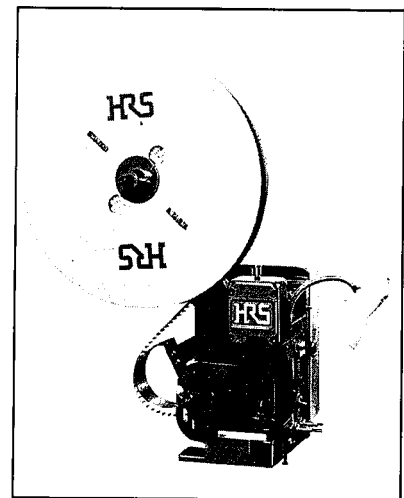

Auto Crimp Tool CM-105

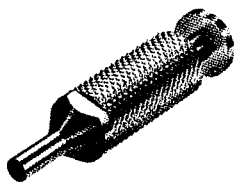

(HR10B-TP)
Coaxial Contact Removal Tool

How to use a Connector

	1. Inserting	2. Withdrawing
HR10 TYPE	<p>Panel Receptacle Plug Cable A</p>	<p>Panel Plug connection sleeve Cable B</p>
HR10A TYPE	<p>Panel Receptacle Plug Cable A</p>	<p>Panel Plug connection sleeve Cable B</p>
	<p>Hold the plug at point A, align the plug guide with the receptacle guide, and push the plug straight. The plug will mate with the receptacle smoothly.</p>	<p>Hold the plug connection sleeve B and pull the sleeve straight. The plug will come off easily.</p>

Wiring Tool

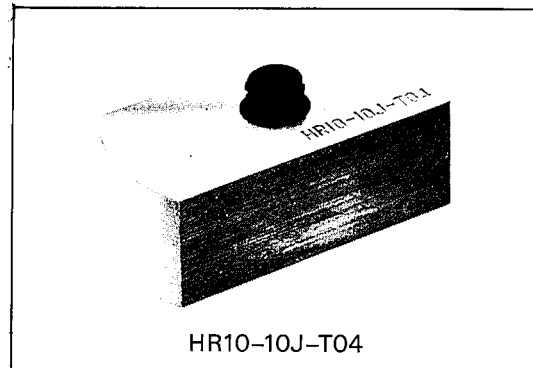
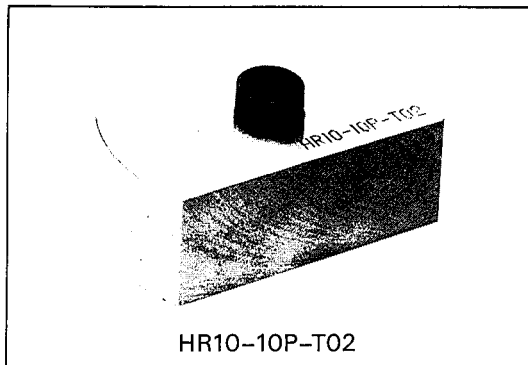

HRS No.	Part No.	Applicable connector
150-0009-0	HR10-7P-T01	HR10-7P
150-0010-9	HR10-10P-T02	HR10-10P
150-0011-1	HR10-7J-T03	HR10-7J
150-0012-4	HR10-10J-T04	HR10-10J
150-0059-8	HR10-13P-T05	HR10-13P
150-0060-7	HR10-13J-T06	HR10-13J
150-0056-0	HR10D-13P-T	HR10D-13P

◆ Connection work procedure(plug side)

- This applies also to the jack side connection work.
- No special connection work procedure is given here for the receptacle side because no special procedure is necessary.

HR10 Type

HR10A Type

Size	HR10	HR10A
Size 7	8	7.5
Size 10	11	9.5
Size 13	—	13

Size	Dimension C for HR10	Dimension D for HR10A	
		Solder type	Crimp type
Size 7	5.5 or less	10	15 - 20
Size 10	7 or less	16	15 - 20
Size 13	—	26	26

Size	Tightening force
Size 7	1.5N·m (15kg-cm)
Size 10	2N·m (20kg-cm)
Size 13	2N·m (20kg-cm)

	HR10 Type	HR10A Type
1	Use cables with a nominal sectional area of 0.129 mm ² (AWG#26) at the finish outside diameters applicable for each size.	
2	After processing the cable ends according to the dimensions in the above drawings, fit the parts to the cable as shown in the drawings. Fit the parts to the cable in the following order: tightener, clamp washer, and plug body.	Fit the parts to the cable in the following order: Cord bushing, and plug body.
3	(Solder type) Insert the P shell unit into the assembly jig stand and solder it. (Solder type) After crimping the appropriate crimp terminal to the cable core, insert the crimp terminal into the terminal hole in the P shell unit.	
4	Assemble the connector in the following steps. ① Screw the plug body into the thread in the P shell unit with the tightening force shown in Table 1 using a torque wrench with a fixed torque. Before tightening the plug body, slacken part C so that no load is applied to the soldered wires. ② Apply the clamp washer to the bifurcated part of the plug body, and then tighten the tightener until surface B touches the plug body surface A.	① Fix by caulking the clamp accompanying the cable with the cable crimping tool (HR10A-TC-02). ② Screw the plug body into the thread in the P shell unit with a tightening force shown in Table 1 using a torque wrench with a fixed torque. Before tightening the plug body, slacken the part D so that no load is applied to the soldered wires. ③ Tighten the set screw so that the tip of the screw presses one of the two bosses on the clamp. Fix the set screw with a tightening torque of 0.3N (3kg-cm). ④ Attach the cord bushing to the plug body.
5	This completes the work.	

For any question on using the plugs, contact our sales or engineering department.

◆ Connector

Male Pin side

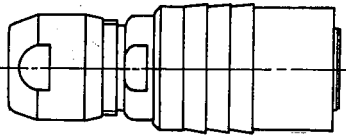

(HR10 type plug)

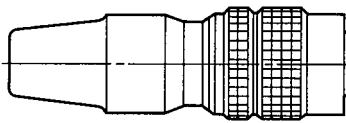

(HR10A Type Plug)

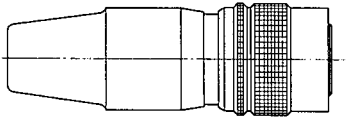

(HR10B Type Plug)

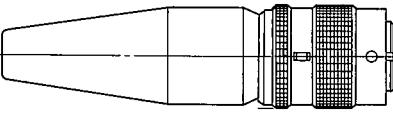

(HR10D Type Plug)

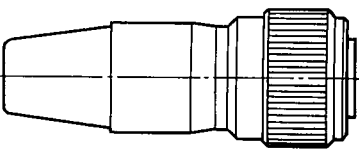

(HR10A-[] T Type Plug)

Female Pin side

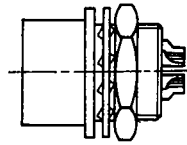

(HR10·HR10A
HR10G type Receptacle)

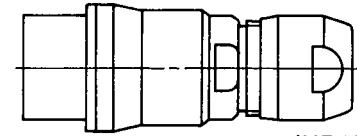

(HR10 Type Jack)

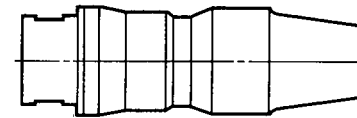

(HR10A Type Jack)

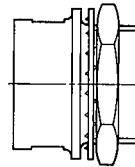

(HR10B Type Receptacle)

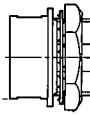

(HR10D Type Receptacle)

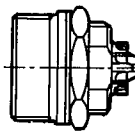

(HR10A-[] T Type Receptacle)

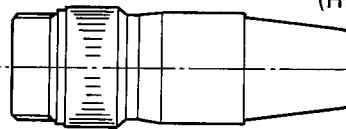

(HR10A-[] T Type Jack)

Notes

- 1: When using a plug with male terminal, be sure to use a receptacle or jack fitted with female terminal.
- 2: Standard finish of the terminal is gold plating for the HR10, and silver plating for the HR10A and HR10G.
Be sure to use male and female connectors of the same plating.

Recommended Mounting Hole

Mounting hole dimension shown here is tight by hexagon nut from back side.

Map mark \ Shell size	7 size	10 size	13 size
A	$1.6^{+0.1}_0$	$2.6^{+0.1}_0$	$2.6^{+0.1}_0$
B	$5.1^{+0.1}_0$	$6.6^{+0.1}_0$	$8.6^{+0.1}_0$
ϕC	$8.1^{+0.1}_0$	$11.1^{+0.1}_0$	$14.1^{+0.1}_0$
Panel thickness	0.7 ~ 2	0.7 ~ 2	0.8 ~ 1.5

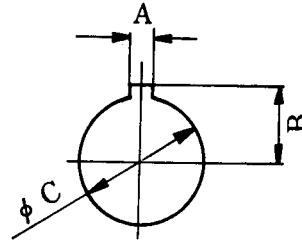

Contact Arrangement

Shell size	7 size			10 size	
Contact arrangement					
No. of pins	4	5	6	10	12
Withstanding voltage	AC500V for a minute	AC300V for a minute			AC300V for a minute
Current rating	2A	2A			2A
Insulation resistance	MIN 1,000 MΩ	MIN 1,000 MΩ			MIN 1,000 MΩ
Contact resistance	MAX 10 mΩ	MAX 10 mΩ			MAX 10 mΩ
Solder pot inside dia.	$\phi 0.8$	$\phi 0.8$			$\phi 0.8$

Shell size	10 size	13 size
Contact arrangement		
No. of pins	10 + Coaxial contact	20
Withstanding voltage	AC300V for a minute	AC300V for a minute
Current rating	2A	2A
Insulation resistance	MIN 1,000 MΩ	MIN 1,000 MΩ
Contact resistance	MAX 10 mΩ	MAX 10 mΩ
Solder pot inside dia.	-	$\phi 0.8$

- Note
1. The contact arrangement shown here is the mating surface of socket insert assembled in a receptacle.
 2. The withstanding voltage shown here is test voltage value.
 3. The insulation resistance value is measured at DC100V.
 4. The contact resistance value is measured at DC1A.