

IEC Power Inlet with Line Filter

- IEC320-C14 Filtered Inlet
- Dual Fuse
- Screw Mount
- Compact Design
- Medical Application
- 1, 3, 6 & 10A Rating
- 6.3 x 0.8mm Faston Terminals
- Bleed Resistor
- Shielded Metal Body
- Wide Operating Temperature Range
- 3 Year Warranty



The FDMM has an IEC320-C14 inlet with a front accessible (when the mains connector is disconnected) dual fuse holder, combined with a low earth leakage medical IEC inlet filter in a compact single housing. It is suitable for mains powered medical equipment where dual fusing and low earth leakage current is required. Providing excellent attenuation to conducted electro-magnetic interference from the mains supply, whilst reducing any conducted emissions from within the equipment onto the mains supply. Suitable for class I appliances, all models feature a shielded metal body, and are fitted with a bleed resistor to safely discharge the filter capacitors when power is disconnected. Safety approvals are EN60939-2 for passive filters & ANSI/UL1283 for EMI filters. They feature a wide operating temperature range of -40°C to +110°C with full power operation up to +50°C.

Specifications

Characteristics	Minimum	Typical	Maximum	Units	Notes and Conditions
Input Voltage	0	115/230	264	VAC	
Input Frequency	DC		400	Hz	
Rated Current	1		10	A	See models and ratings table
Earth Leakage Current	2		5	µA	See models and ratings table
MTBF	1.35			MHrs	MIL-STD 217F
Flammability Rating	UL94V-2				
Temperature Operating	-40		110	°C	See derating curve
Safety Approvals	EN60939-2				Passive filter units for EMI suppression
	ANSI/UL1283				Electromagnetic Interference Filters
Terminals	Faston 6.3 x 0.8mm straight				
Protection Class	Suitable for appliances with protection Class I				
Dielectric Strength		1500		VAC	

Electrical Schematic

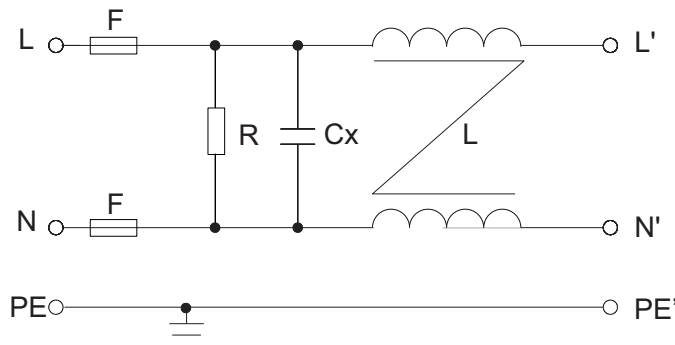

Note: Fuses not supplied

Models & Ratings

Rated current	Leakage current		Inductance @10kHz, 0.25V	Capacitance		Resistance	Weight	Application	Mounting	Filter
	115VAC/60Hz	250VAC/50Hz		Cx	Cy					
1A	2 μ A	5 μ A	2 x 6.5mH	0.1 μ F	None	1M Ω	55g	Medical	Screw	FDMM01SFR
3A	2 μ A	5 μ A	2 x 2.5mH	0.1 μ F	None	1M Ω	55g	Medical	Screw	FDMM03SFR
6A	2 μ A	5 μ A	2 x 0.8mH	0.1 μ F	None	1M Ω	53g	Medical	Screw	FDMM06SFR
10A	2 μ A	5 μ A	2 x 0.2mH	0.1 μ F	None	1M Ω	56g	Medical	Screw	FDMM10SFR

Thermal Derating

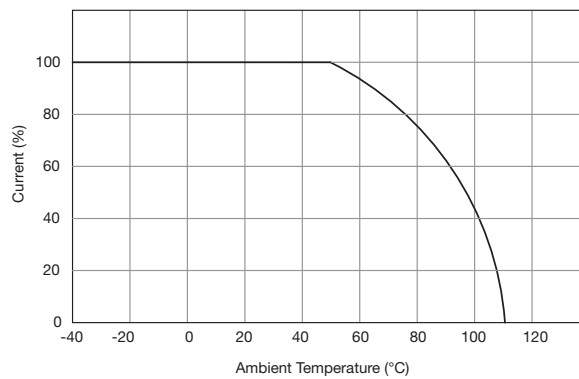

Mechanical Details

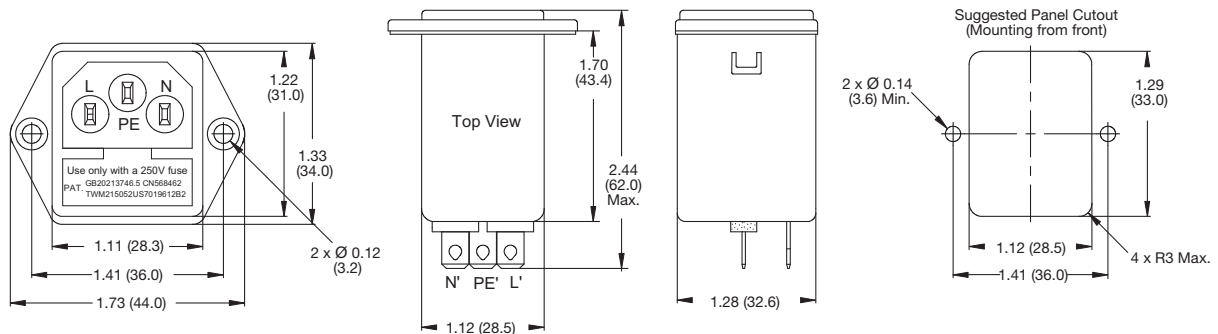

Output Terminals: 6.3 mm x 0.8 mm Fast-ons

Typical Attenuation Curves

———— Common Mode/Asymmetrical(L-G) - - - - - Differential Mode/Symmetrical(L-L)

FDMM01SFR

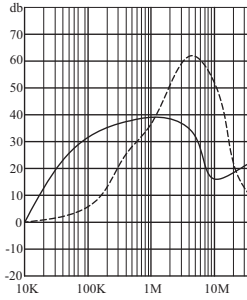

FDMM03SFR

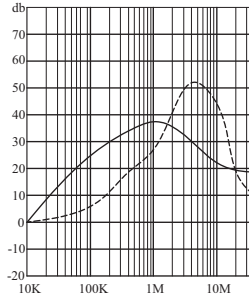

FDMM06SFR

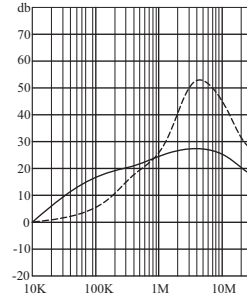

FDMM10SFR

