

MAX40242 Evaluation Kit

Evaluates: MAX40242

General Description

The MAX40242 evaluation kit (EV kit) provides a proven design to evaluate the MAX40242 low-input bias current, low-noise operational amplifier (op amp) in an 8-pin μ MAX[®] package. The EV kit circuit is preconfigured as noninverting amplifiers, but can be adapted to other topologies by changing a few components. The component pads accommodate 0805 packages, making them easy to solder and replace. The EV kit comes with a MAX40242ANA+ installed.

Features

- Accommodates Multiple Op-Amp Configurations
- Rail-to-Rail Outputs
- Accommodates Easy-to-Use 0805 Components
- 2.7V to 20V Single Supply or ± 1.35 V to ± 10 V Dual Supplies
- Proven PCB Layout
- Fully Assembled and Tested

Ordering Information appears at end of data sheet.

MAX40242 EV Kit Photo

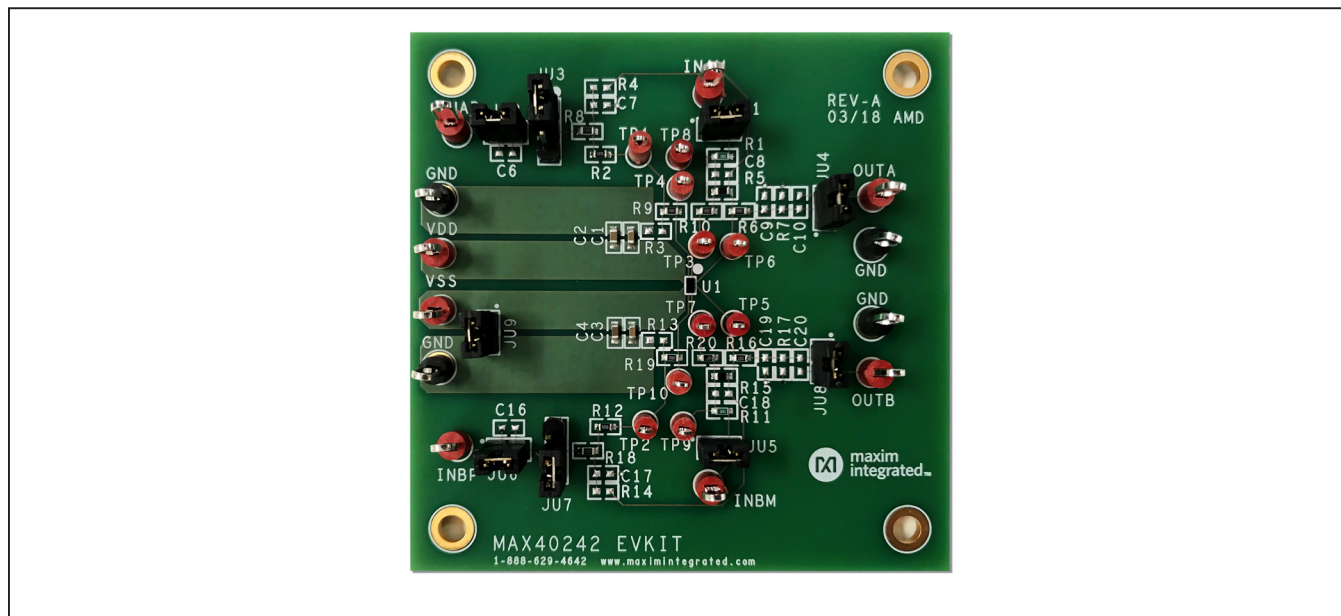

μ MAX is a registered trademark of Maxim Integrated Products, Inc.

Quick Start

Required Equipment

- MAX40242 EV kit
- +5V, 10mA DC power supply (PS1)
- Two precision voltage sources
- Two digital multimeters (DMMs)

Procedure

The EV kit is fully assembled and tested. Follow the steps below to verify board operation. **Caution: Do not turn on power supplies until all connections are completed and turn on V_{DD} , V_{SS} supplies before turning on voltage sources on the input pins.**

- 1) Verify that the jumpers are in their default position, as shown in [Table 1](#).
- 2) Connect the positive terminal of the +5V supply to V_{DD} and the negative terminal to GND test points.
- 3) Connect the positive terminal of the precision voltage source to INAP. Connect the negative terminal of the precision voltage source to GND.

- 4) Connect the positive terminal of the second precision voltage source to the INBP pad. Connect the negative terminal of the precision voltage source to GND.
- 5) Connect the Multimeters to monitor the voltages on OUTA and OUTB. With the 9k Ω feedback resistors and 1k Ω series resistors, the gain of each noninverting amplifier is +10V/V.
- 6) Turn on the +5V power supply.
- 7) Apply 100mV from the precision voltage sources. Observe the output at OUTA and OUTB on the DMMs. Both should read approximately +1V.
- 8) Apply 450mV from the precision voltage sources. Both OUTA and OUTB should read approximately +4.5V.

Once the above steps are confirmed, the EV kit is tested for functionality.

Detailed Description of Hardware

The MAX40242 EV kit provides a proven layout for the MAX40242 low input bias current, low-noise dual op amp.

The IC is a single-supply dual op amp whose primary application is operating in the noninverting configuration; however, the IC can operate with a dual supply as long as the voltage across the V_{DD} and GND pins of the IC do not exceed the absolute maximum ratings. When operating with a single supply, short V_{SS} to GND.

Op-Amp Configurations

The IC is a single-supply dual op amp ideal for differential sensing, noninverting amplification, buffering, and filtering. A few common configurations are shown in the next few sections.

The following sections explain how to configure one of the device's op amps (op-amp A). To configure the device's second op amp (op-amp B), the same equations can be used after modifying the component reference designators. For op-amp B, the equations should be modified by

Table 1. Jumper Descriptions (JU1–JU8)

JUMPER	SHUNT POSITION	DESCRIPTION
JU1	Installed*	Terminating Inverting input of CHA to GND through Gain Resistor
	Not Installed	Floating Inverting input of CHA to GND through Gain Resistor
JU2	Installed*	For Non-Inverting configuration of CHA, apply Input on INAP
	Not Installed	Floating Non-Inverting input of CHA Resistor
JU3	1-2*	For Non-Inverting configuration on CHA
	2-3	Terminating Non-Inverting input of CHA to GND
JU4	Install*	Jumper to pass on signal from OUTA pin of CHA to OUTA test point
	Not Installed	No signal on OUTA test point from OUTA pin
JU5	Installed*	Terminating Inverting input of CHB to GND through Gain Resistor
	Not Installed	Floating Inverting input of CHB to GND through Gain Resistor
JU6	Installed*	For Non-Inverting configuration of CHB, apply Input on INBP
	Not Installed	Floating Non-Inverting input of CHB
JU7	1-2*	For Non-Inverting configuration on CHB
	2-3	Terminating Non-Inverting input of CHB to GND
JU8	Install*	Jumper to pass on signal from OUTB pin of CHB to OUTB test point
	Not Installed	No signal on OUTB test point from OUTB pin
JU9	Install*	Single-supply operation
	Not Installed	Float V_{SS} pin to enable Split-supply operation

*Default position.

adding 10 to the number portion of the reference designators (e.g., for the noninverting configuration, equation R1 becomes R11 and R5 becomes R15).

Noninverting Configuration

The EV kit comes preconfigured as a noninverting amplifier. The gain is set by the ratio of R5 and R1. The EV kit comes preconfigured for a gain of 10V/V. The output voltage for the noninverting configuration is given by the equation below:

$$V_{OUTA} = \left(1 + \frac{R5}{R1}\right) V_{INAP}$$

Differential Amplifier

To configure the EV kit as a differential amplifier, replace R1–R3, and R5 with appropriate resistors. When R1 = R2 and R3 = R5, the CMRR of the differential amplifier is determined by the matching of the resistor ratios R1/R2 and R3/R5.

$$V_{OUTA} = GAIN(V_{INAP} - V_{INAM})$$

where:

$$GAIN = \frac{R5}{R1} = \frac{R3}{R2}$$

Sallen-Key Filter Configuration

The Sallen-Key filter topology is ideal for filtering sensor signals with a second-order filter and acting as a buffer. Schematic complexity is reduced by combining the filter and buffer operations. The EV kit can be configured in a Sallen-Key topology by replacing and populating a few components. The Sallen-Key topology is typically configured as a unity-gain buffer, which can be done by replacing R1 and R5 with open and 0Ω resistors, respectively and short JU2. The noninverting signal is applied to the INAP test point with JU2 short and short pins 1-2 on JU3 or do the same on the INBP pad similarly. The filter component pads are R2–R4, and R8, where some have to be populated with resistors and others with capacitors. We will go into detail below on these details.

Lowpass Sallen-Key Filter

To configure the Sallen-Key as a lowpass filter, populate the R2 and R8 pads with resistors, and populate the R3 and R4 pads with capacitors. The corner frequency and Q are then given by:

$$f_C = \frac{1}{2\pi\sqrt{R_{R2}R_{R8}C_{R3}C_{R4}}}$$

$$Q = \frac{\sqrt{R_{R2}R_{R8}C_{R3}C_{R4}}}{C_{R3}(R_{R2} + R_{R8})}$$

Highpass Sallen-Key Filter

To configure the Sallen-Key as a highpass filter, populate the R3 and R4 pads with resistors and populate the R2 and R8 pads with capacitors. The corner frequency and Q are then given by:

$$f_C = \frac{1}{2\pi\sqrt{R_{R3}R_{R4}C_{R2}C_{R8}}}$$

$$Q = \frac{\sqrt{R_{R3}R_{R4}C_{R2}C_{R8}}}{R_{R4}(C_{R2} + C_{R8})}$$

Transimpedance Application

To configure op-amp U1-A as a transimpedance amplifier (TIA), replace R1 with photo-diode with bias accordingly and shunt on pins 2-3 on jumper JU3. The output voltage of the TIA is the input current multiplied by the feedback resistor:

$$V_{OUT} = (I_{IN} + I_{BIAS}) \times R4 + V_{OS}$$

where R4 is installed as a 9kΩ resistor, I_{IN} is defined as the input current source applied by photo-diode or a current source, I_{BIAS} is the input bias current, and V_{OS} is the input offset voltage of the op amp. Use capacitor C8 (and C7, if applicable) to stabilize the op amp by rolling off high-frequency gain due to a large cable capacitance. Similarly, we can configure op-amp U1-B for transimpedance application.

Capacitive Loads

Some applications require driving large capacitive loads. To improve the stability of the amplifier, replace R6 (R16 for U1-B) with a suitable resistor value to improve amplifier phase margin. The R6/C9 (R16/C19 for U1-B) filter can also be used as an anti-alias filter, or to limit amplifier output noise by reducing its output bandwidth.

Ordering Information

PART	TYPE
MAX40242EVKIT#	EV Kit

#Denotes ROHS compliant.

MAX40242 EV Kit Bill of Materials

NOTE: DNI-> DO NOT INSTALL(PACKOUT); DNP-> DO NOT PROCURE

ITEM	REF DES	DNI/D NP	QTY	MFG PART #	MFG	VALUE	DESCRIPTION	CMNTS
1	C1, C3	-	2	C0603C104K3RAC; GRM188R71E104KA01; C160X7R1E104K	KEYMET; MURATA; TDK	0.1UF	CAPACITOR; SMT; 0603; CERAMIC; 0.1UF; 25V; 10%; X7R; -55degC to +125degC; +/-15% from -55degC to +125degC;	
2	C2, C4	-	2	C160X5R1E475K080AC; GRM188R61E475KE11	TDK; MURATA	4.7UF	CAPACITOR; SMT (0603); CERAMIC CHIP; 4.7UF; 25V; 10%; TG=-55 DEGC TO +85 DEGC; TC=>X5R	
3	GND, GND1-GND3	-	4	5011	KEYSTONE	N/A	TESTPOINT; PINDIA=0.125IN; TOTAL LENGTH=0.445IN; BOARD HOLE=0.063IN; BLACK; PHOSPHOR BRONZE WIRE SILVER PLATE FINISH;	(GND1-GND3; GND)
4	INAM, INAP, INBM, INBP, OUTA, OUTB, VDD, VSS	-	8	5010	KEYSTONE	N/A	TESTPOINT; WITH 1.80MM HOLE DIA. RED. MULTIPURPOSE;	
5	JU1, JU2, JU4-JU6, JU8, JU9	-	7	PCC02SAAN	SULLINS	PCC02SAAN	CONNECTOR; MALE; THROUGH HOLE; BREAKAWAY; STRAIGHT THROUGH; 2PINS; -65 DEGC TO +125 DEGC	
6	JU3, JU7	-	2	PCC03SAAN	SULLINS	PCC03SAAN	CONNECTOR; MALE; THROUGH HOLE; BREAKAWAY; STRAIGHT THROUGH; 3PINS; -65 DEGC TO +125 DEGC	
7	R1, R11	-	2	TNPW06031K00BE;	VISHAY DALE;	1K	RESISTOR; 0603; 1K OHM; 0.1%; 25PPM; 0.10W; THICK FILM	
8	R2, R12	-	2	RG1608P-102-B	SUSUMU CO LTD;	909	RESISTOR; 0603; 909 OHMS; 1%; 100PPM; 0.1W; THICK FILM	
9	R5, R15	-	2	CAR0603 9K OHMS 0.01% 5PPM HP	VISHAY DALE	9K	RESISTOR; 0603; 9K OHM; 0.01%; 5PPM; 0.1W; THIN FILM	
10	R6, R8-R10, R16, R18-R20	-	8	RC1608J000CS; CR0603-JI-000ELF; RC0603JRR-070RL	RIEDON INC SAMSUNG ELECTRONICS; BOURNS; YAGEO PH	0	RESISTOR; 0603; 0 OHM; 5%; JUMPER; 0.10W; THICK FILM TEST POINT; JUMPER; STR; TOTAL LENGTH=0.24IN; BLACK; INSULATION=PBT; PHOSPHOR BRONZE CONTACT=GOLD PLATED	
11	SU1-SU8	-	8	S1100-B; SX1100-B	KYCON; KYCON	SX1100-B	TEST POINT; PIN DIA=0.1IN; TOTAL LENGTH=0.3IN; BOARD HOLE=0.04IN; RED;	
12	TP1-TP10	-	10	5000	KEYSTONE	N/A	PHOSPHOR BRONZE WIRE SILVER PLATE FINISH;	
13	U1	-	1	MAX40242	MAXIM	MAX40242	EVKIT PART - IC; OPAMP; MAX40242; PACKAGE OUTLINE DRAWING: 21-100280;	
14	PCB	-	1	MAX	MAXIM	PCB	PACKAGE CODE: N80D1+1; WLP8	
15	C6-C10, C16-C20	DNP	0	N/A	N/A	OPEN	PCB:MAX	-
16	R3, R4, R7, R13, R14, R17	DNP	0	N/A	N/A	OPEN	PACKAGE OUTLINE 0603 NON-POLAR CAPACITOR	
TOTAL			59				PACKAGE OUTLINE 0603 RESISTOR	

MAX40242 EV Kit Schematic

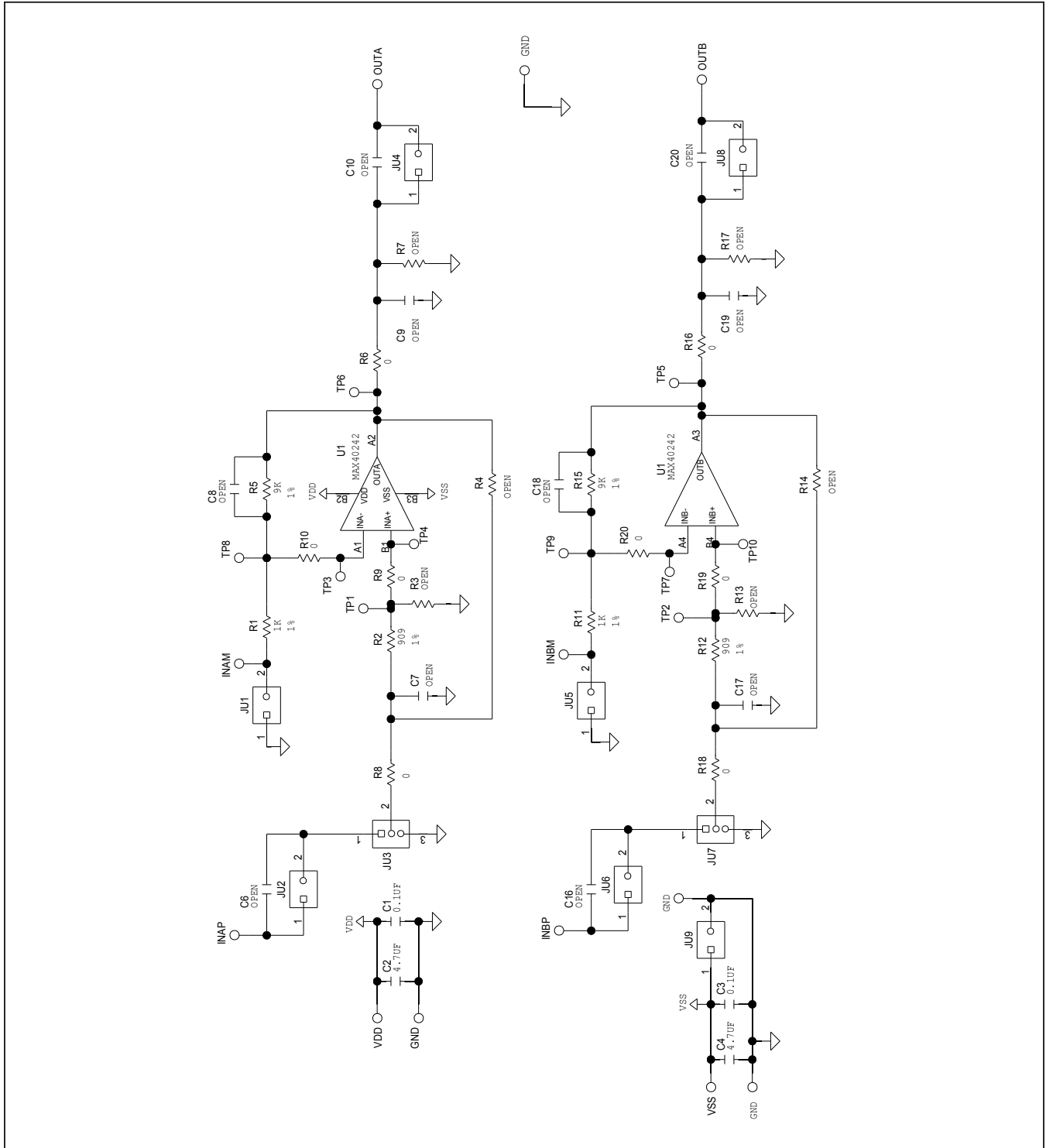

MAX40242 EV Kit PCB Layouts

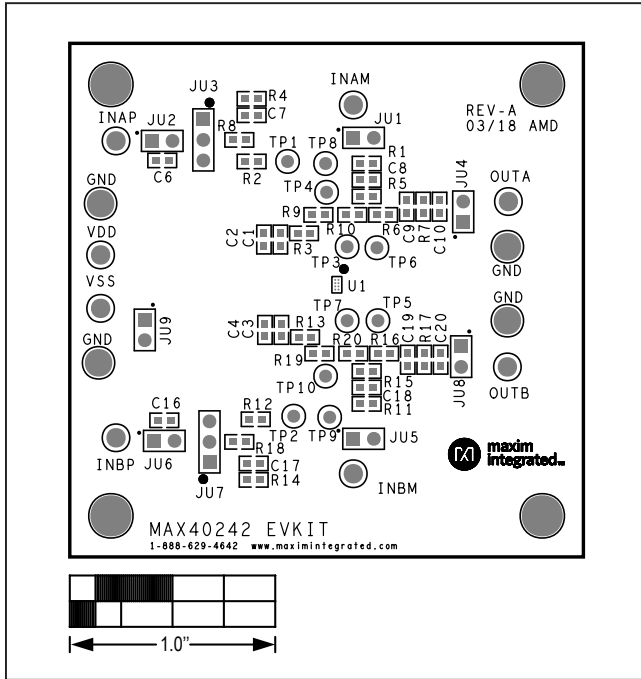

MAX40242 EV Kit Component Placement Guide—Component Side

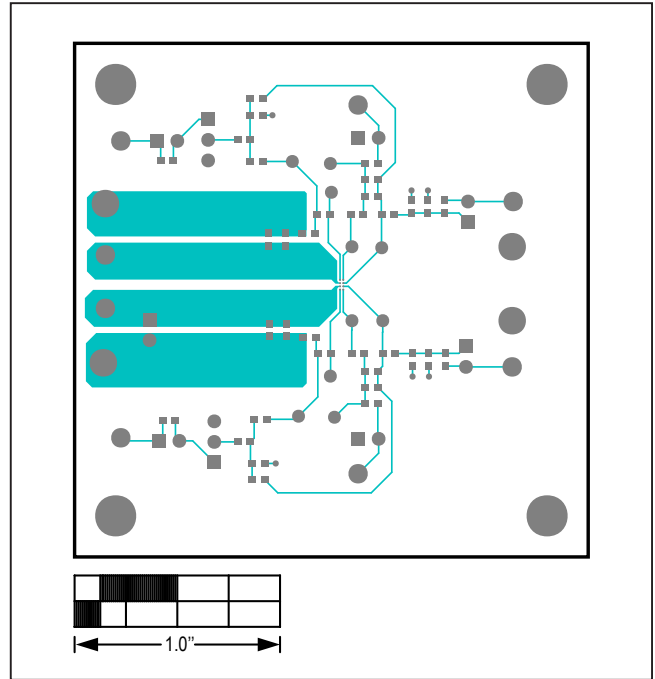

MAX40242 EV Kit PCB Layout—Component Side

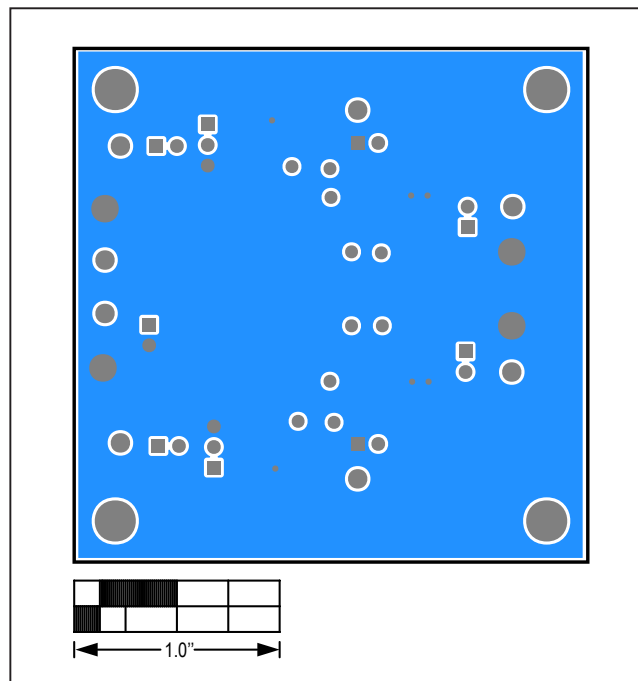

MAX40242 EV Kit PCB Layout—Solder Side

Revision History

REVISION NUMBER	REVISION DATE	DESCRIPTION	PAGES CHANGED
0	12/18	Initial release	—

For pricing, delivery, and ordering information, please visit Maxim Integrated's online storefront at <https://www.maximintegrated.com/en/storefront/storefront.html>.

Maxim Integrated cannot assume responsibility for use of any circuitry other than circuitry entirely embodied in a Maxim Integrated product. No circuit patent licenses are implied. Maxim Integrated reserves the right to change the circuitry and specifications without notice at any time.