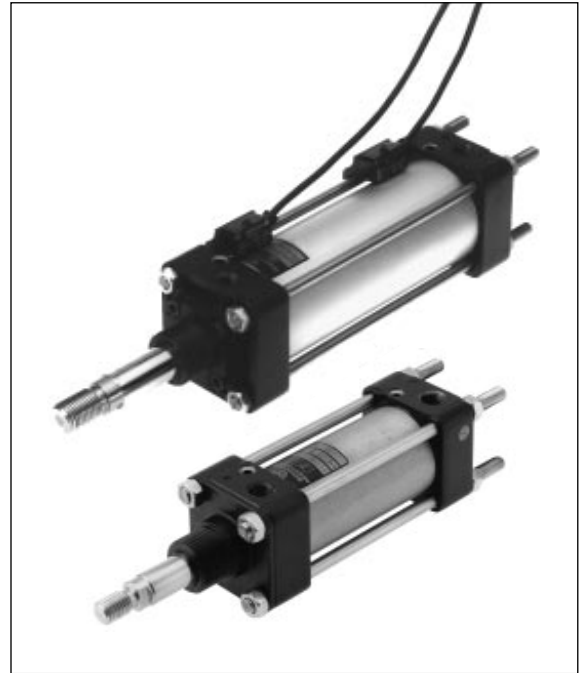

Standard Cylinder
Non-magnet and Magnet Piston
Double acting
 Ø 1 1/4 inch to 14 inch (Ø 32 to 355 mm)

- Ideal for a wide range of industrial applications
- Extensive range of mountings
- Rugged, reliable long established design

Technical Data

Medium:

Compressed air, filtered, lubricated or non-lubricated

Operating:

RM/900 Double acting with adjustable cushioning

RM/900/M Double acting with adjustable cushioning and magnetic piston

Operating Pressure:

2 to 10 bar

Operating Temperature:

-20°C* to +80°C

*Consult our Technical Service for use below +2°C

Cylinder Diameters:

RM/900 1 1/4, 1 3/4, 2, 2 1/2, 3, 4, 5, 6, 8, 10, 12, 14 inch

RM/900/M 1 1/4, 1 3/4, 2, 2 1/2, 3, 4 inch

Standard Strokes:

9125 50, 75, 100, 125, 150, 200, 300 mm

9175 bis 980 100, 150, 200, 300, 400, 500 mm

Non-standard Strokes:

Available on request

Materials:

Stainless steel (Martensitic) piston rod and tie rods, anodised aluminium alloy barrel for Ø 1 1/4 inch to 12 inch (Ø 14 inch steel), aluminium piston and end covers, brass bearing housings for Ø 1 1/4 inch to 3 inch (Ø 4 inch to 14 inch aluminium), nitrile rubber seals

Alternative Cylinders:

See page N 1.5.161.02

Ordering Information

To order a basic 2 inch bore cylinder with a 300 mm stroke without mounting brackets quote: RM/920/300

To order a basic 3 inch bore cylinder with a 400 mm stroke and central trunnion mounting style 'H' (XV=125 mm) and piston rod clevis mounting style 'F' quote: RM/930/400 with mountings M/P8637 (XV=125 mm) and QM/407
To order mounting brackets refer to appropriate cylinder mounting table.

Order magnetically operated switches separately.

Accessories

See page

Switches	QM/31, QM/32	N 4.3.021.01
Switch	QM/132	N 4.3.025.01
Switches	QM/33, QM/34	N 4.3.051.01
Switch	QM/134	N 4.3.055.01
Servo-cylinders		N 1.9.041.01

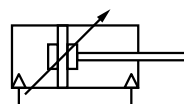

Non-magnetic piston

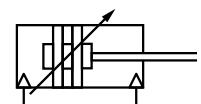

Magnetic piston





Alternative Cylinders

Symbol	Model (non-magnetic piston)	Symbol	Model (magnetic piston)	Description
	CM/900			Hard chromium plated piston rod
	SM/900			Stainless steel piston rod (Austenitic)
	TRM/900			Heat resistant seals (150°C max.)
	RM/900/X		RM/900/MX	Female piston rod thread
	RM/900/Y		RM/900/MY	Full piston rod thread
	RM/900/IU		RM/900/MU	Extended piston rod
	HRM/900			Hydraulic version up to Ø 4" - consult our Technical Service
	RM/900/J			Double ended piston rod
	RM/900/G			Piston rod bellows Dimensions see page N 1.5.161.08

For combinations of alternative cylinders consult our Technical Service.

Cushioning • Theoretical Forces • Air Consumption

Model	Cushion length (mm)	Initial cushion volume (cm ³)	Theoretical forces (N) at 6 bar		Air consumption (l/cm) per stroke at 6 bar	
			outstroke	instroke	outstroke	instroke
9125	20	12	482	406	0,056	0,047
9175	20	25	933	812	0,109	0,095
920	20	29	1225	1055	0,143	0,124
925	21	48	1930	1626	0,225	0,190
930	29	109	2721	2417	0,318	0,282
940	38	265	4902	4420	0,572	0,516
950	29	314,7	7600	6920	0,887	0,807
960	32	538,5	10887	10207	1,270	1,191
980	44	1428	19419	18486	2,266	2,157
9100	50	2754	30402	28871	3,547	3,368
9120	50	4257	43837	42306	5,114	4,936
9140	50	6725	59723	58192	6,968	6,789

Weights of Cylinders and Mountings (kg)

Model	RM/900 Weight at 0 mm	Weight per 25 mm	RM/900/J Weight at 0 mm	Weight per 25 mm	 Style 'B'	 Style 'C'	 Style 'D'	 Style 'F'	 Style 'G'	 Style 'H'
9125	0,47	0,06	0,65	0,08	0,15	0,06	0,08	0,03	0,15	0,16
9175	0,91	0,10	1,21	0,13	0,20	0,20	0,15	0,05	0,20	0,50
920	1,15	0,13	1,66	0,19	0,20	0,20	0,25	0,10	0,20	0,60
925	1,93	0,17	2,82	0,27	0,25	0,25	0,25	0,40	0,25	0,90
930	3,02	0,20	3,86	0,30	0,45	0,30	0,75	0,40	0,45	1,25
940	4,01	0,26	5,31	0,41	1,00	0,65	1,25	0,90	1,00	2,50
950	9,10	0,55	11,85	0,77	1,50	1,00	2,50	1,25	1,50	3,50
960	12,80	0,80	15,60	1,02	2,40	2,50	3,50	1,25	2,40	5,00
980	23,00	1,00	26,91	1,30	5,50	3,50	7,00	1,70	5,50	10,00
9100	73,40	1,90	81,10	2,39	12,00	8,00	-	2,75	12,00	25,00
9120	98,60	2,10	105,30	2,59	14,00	9,50	-	2,75	14,00	35,00
9140	99,80	3,00	109,00	3,30	23,00	20,50	-	4,50	23,00	51,50
Model	 Style 'K'	 Style 'L'	 Style 'M'	 Style 'N'	 Style 'R'	 Style 'UF'	 Style 'UH'	 Style 'UR'	 Switch bracket	 Switch bracket
9125	0,08	0,25	0,17	0,02	0,10	0,07	0,24	0,18	0,03	0,01
9175	0,15	1,10	0,30	0,04	0,26	0,13	0,43	0,30	0,03	0,01
920	0,25	1,20	0,40	0,04	0,55	0,17	0,70	0,43	0,03	0,01
925	0,25	1,25	1,00	0,04	0,80	0,43	1,14	0,60	0,04	0,01
930	0,75	1,50	1,00	0,04	0,90	0,43	1,30	0,75	0,04	0,01
940	1,25	3,50	2,00	0,06	2,60	0,44	2,32	2,40	0,04	0,01
950	2,50	5,00	3,00	0,18	3,60	-	-	2,70	-	-
960	3,50	11,00	3,00	0,18	6,20	-	-	4,60	-	-
980	7,00	17,50	6,00	-	11,50	-	-	7,30	-	-
9100	-	25,00	9,00	-	12,60	-	-	-	-	-
9120	-	30,00	9,00	-	17,30	-	-	-	-	-
9140	-	61,00	10,50	-	32,80	-	-	-	-	-



Basic Dimensions

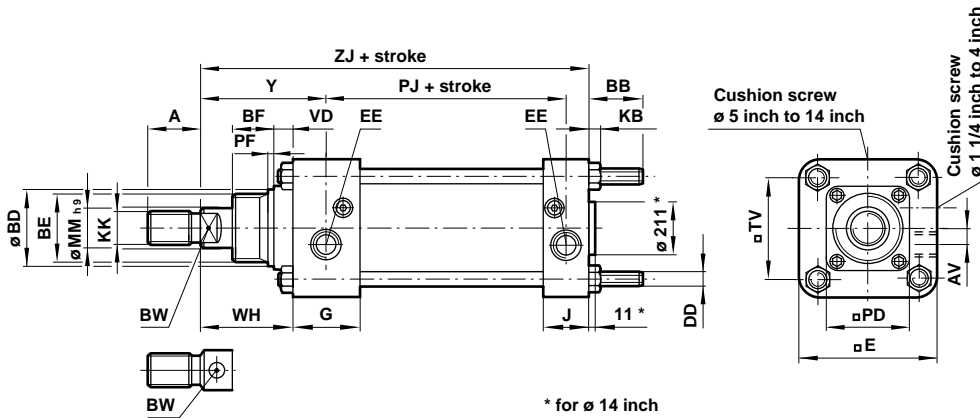

Piston Rod End Style 'X'

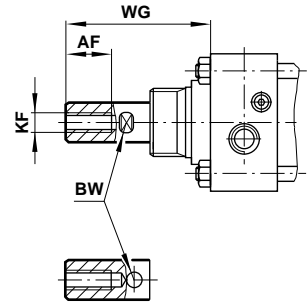

Double ended piston rod

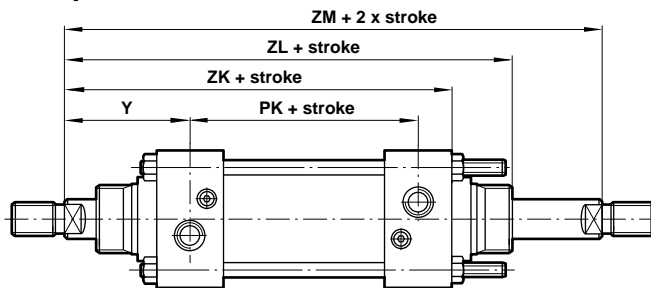

Piston Rod End Style 'Y'

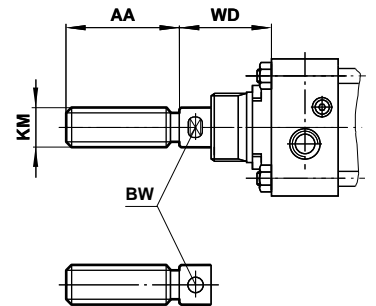

Model	9125	9175	920	925	930	940	950	960	980	9100	9120	9140
Ø inch	1 1/4	1 3/4	2	2 1/2	3	4	5	6	8	10	12	14
A	14,5	19	24	33,5	33,5	38	47,5	47,5	57	76	76	76
AA	29,5	35,5	43	58	58	73	88	88	103	134	134	134
AF	14	14	19	29	29	38	48	48	57	76	76	76
AV	6	8,5	7,5	8	7	12	-	-	-	-	-	-
BB	22	26,5	25	25	33	32	48	49,5	53,5	70,5	70,5	93
Ø BD	22	27	34	40	40	-	-	-	-	-	-	-
BE	M 22 x 2	M 27 x 2	M 33 x 2	M 39 x 2	M 39 x 2	Ø 43	Ø 58,5	Ø 58,5	Ø 63,5	Ø 77	Ø 77	Ø 89
BF	19	19	20	25,5	25,5	-	-	-	-	-	-	-
BW	10 (A/F)	12 (A/F)	17 (A/F)	22 (A/F)	22 (A/F)	27 (A/F)	Ø 10	Ø 10	Ø 10	Ø 10	Ø 10	Ø 10
DD	M 6	M 8	M 8	M 8	M 10	M 10	M 12	M 16	M 18	M 24	M 24	M 30
□ E	45	57	63,5	74,5	91	114	140	167	219	270	321	375
EE	G 1/8	G 1/4	G 1/4	G 3/8	G 3/8	G 3/8	G 1/2	G 1/2	G 3/4	G 1	G 1	G 1
G	25	29	29,5	30	35	35	41	41	52	60	60	60
J	22	25	24	25	35	35	41	41	52	60	60	60
KB	5	6,5	6,5	6,5	8	8	10	13	15	19	19	24
KF	M 10	M 10	M 12	M 18	M 18	M 24	M 30	M 30	M 30	M 42	M 42	M 42
KK	M 10	M 12	M 16	M 22	M 22	M 24	M 30	M 30	M 36	M 48	M 48	M 48
KM	M 12	M 16	M 18	M 24	M 24	M 30	M 36	M 36	M 42	M 56	M 56	M 56
Ø MM h9	12	16	20	25	25	32	1 1/2 inch	1 1/2 inch	1 3/4 inch	2 1/4 inch	2 1/4 inch	2 1/4 inch
□ PD	-	-	-	-	59	63,5	82,5	82,5	89	111	111	-
PF	-	-	3	3	3	-	-	-	-	-	-	-
PJ	69	70	67	73	95	97	109	115,5	145,5	173,5	173,5	187,5
PK	66,5	69,5	67	72,5	95	96,5	109	115,5	145,5	173,5	173,5	187,5
TV	30,5	43	47,5	55,5	66,5	89	108	128,5	168,5	209,5	246	292
VD	8	8	9,5	8	13	13	18	18	19	22	22	32
WD	39,5	41	56,5	55	60	67	87	87	91	111,5	111,5	130,5
WG	50,5	54,5	64,5	84,5	89,5	105	133,5	133,5	149,5	191,5	191,5	210,5
WH	37	37	46	53	56,5	64	83	83	86	109	109	128
Y	49,5	52	60,5	68,5	71	77,5	101	101	108,5	139,5	139,5	153,5
ZJ	125,5	132,5	137	152,5	179,5	187,5	228,5	235	276	343	343	366,5
ZK	128,5	136,5	142,5	157	179,5	187,5	228,5	235	276	343	343	366,5
ZL	155,5	163,5	172	190,5	218	232	292	298,5	339,5	419	419	462
ZM	165,5	173,5	187,5	210	237	251,5	311,5	318	362	452	452	494,5



**Rear Flange Mounting Style 'B', Front Flange Mounting Style 'G'
Front and Rear Flange Mounting Style 'BG'**

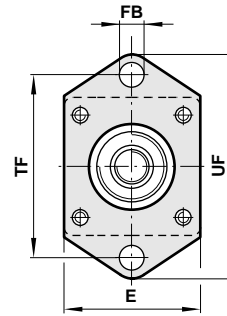
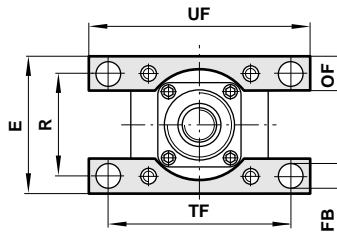
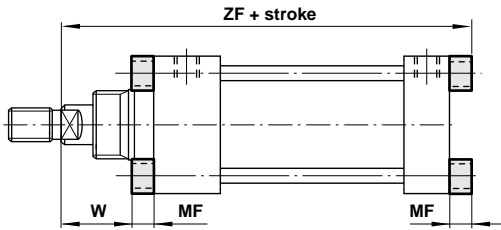

For Cylinder 9125

Foot Mounting Style 'C'

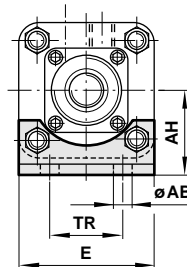
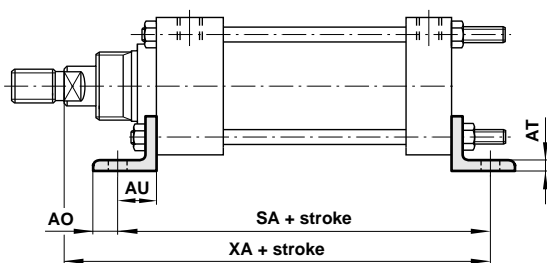

Nose Mounting Style 'N'

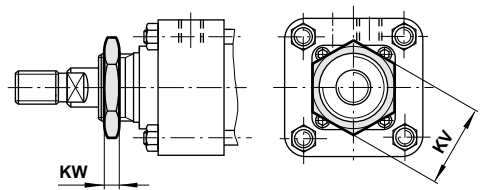

Model 'B'	M/P6938	QM/888	QM/875	QM/876	QM/878	QM/887	QM/886	QM/884	QM/883	QM/882	QM/889	QM/741
Model 'BG'	QM/819	QM/1181	QM/1182	QM/1184	QM/1185	QM/1187	QM/1188	QM/1189	QM/1190			
Model 'C'	QM/754	QM/753	QM/752	QM/748	QM/983	QM/982	QM/981	QM/826	QM/825	QM/824	QM/756	QM/755
Model 'G'	M/P6938	QM/986	QM/871	QM/877	QM/984	QM/987	QM/988	QM/884	QM/883	QM/882	QM/889	QM/741
Model 'N'	M/P11716	M/P7955	M/P9969	M/P9905	M/P9905	QM/1475*	QM/997*	QM/997*				
Cylinder	9125	9175	920	925	930	940	950	960	980	9100	9120	9140
∅ AB	6,8	10,5	13	13	13	13,5	17,5	17,5	17,5	26	26	33,5
AH	24	37,5	40	46,5	52,5	70	82,5	99,5	122	159	177	212,5
AO	6,5	11	11	11	11	24,5	21,5	25	22	46	46	33,5
AT	6,5	5	5	5	5	8	8	10	10	15	15	15
AU	14,5	19	19	19	19	25,5	28,5	35	38	54	54	66,5
E	45	59	64	75,5	88,5	121	148	168,5	218,5	274,5	311	368
FB	8	9	9	9	11,5	14	14,5	18	22	26	26	33
KV (A/F)	28	38	43	48	48	57	70	70				
KW	6,5	8	8	8	8	8	12,5	12,5				
MF	9,5	10	10	10	16	16	20	20	25	30	30	38
OF	-	16	16	20	22	32	40	40	50	65	65	76
R	-	43	47,5	55,5	66,5	89	108	128,5	168	209,5	246	292
SA	117	133,5	129,5	137,5	160	174	202,5	222	266	341,5	341,5	372
TF	63,5	81	85,5	93,5	111	146	171,5	205	263,5	333,5	384	457
TR	-	-	-	30	28,5	51	57	70	82,5	114,5	139,5	159
UF	79	98,5	105	113	133,5	178	203	243	314,5	397	448	533
W	27,5	27	35,5	43	41,5	48	63	63	61	79	79	90
XA	139,5	151,5	156	171,5	198,5	212,5	257	270	314	397	397	433,5
ZF	135	142,5	147	162,5	195,5	203,5	248,5	255	301	373	373	405

Note: When fitted with a Foot Mounting Style 'C' the maximum pressure for the 14 inch bore model is 8 bar.

* These cannot be supplied separately. If a spare Nose Mounting is required, specify basic cylinder reference with 'O' prefix and -/06 suffix, e.g. QM/950/N/06.



Rear Hinge Mounting Style 'L'

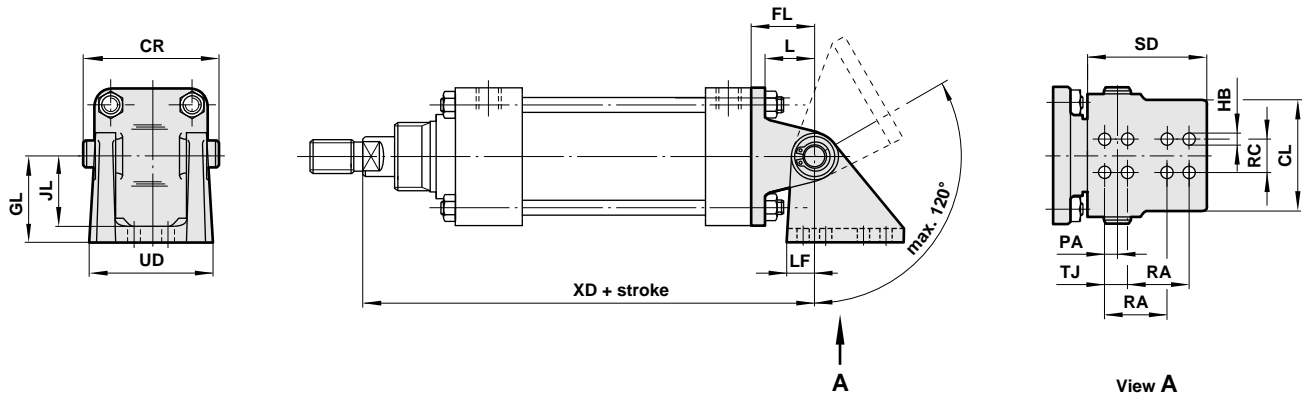

Front Hinge Mounting Style 'M'

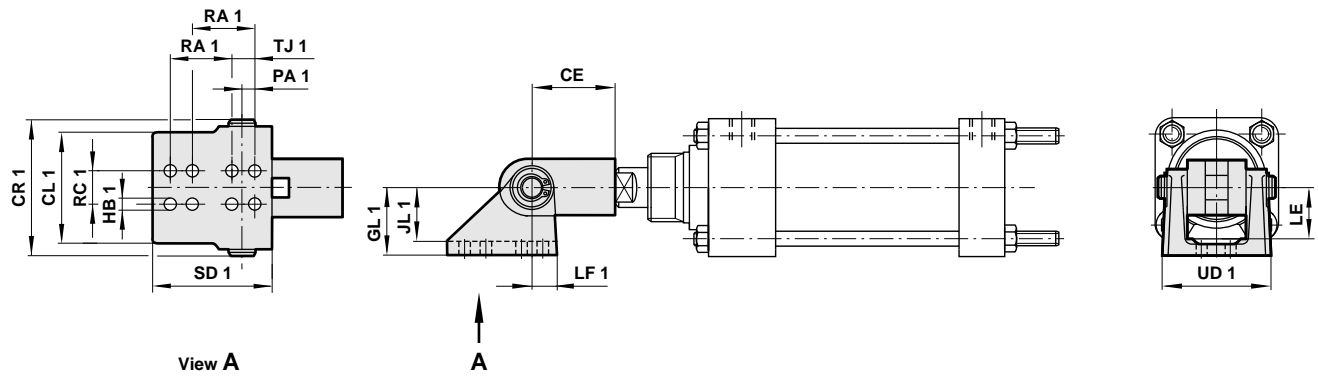

Model 'L'	QM/394	QM/922	QM/909	QM/910	QM/911	QM/912	QM/913	QM/914	QM/915	QM/917	QM/918	QM/924
Model 'M'	QM/393	QM/923	QM/908	QM/901	QM/901	QM/902	QM/903	QM/903	QM/904	QM/919	QM/919	QM/919
Cylinder	9125	9175	920	925	930	940	950	960	980	9100	9120	9140
CE	25,5	33,5	41,5	58,5	58,5	66,5	79,5	79,5	95,5	120,5	120,5	120,5
CL	31	32	60	60	60	70	70	98,5	100	151	151	210
CL 1	31	32	43	60	60	70	79,5	79,5	98,5	124	124	124
CR	39,5	44,5	73	73	73	82,5	82,5	114,5	114,5	178	178	239
CR 1	39,5	44,5	54	73	73	82,5	92	92	114,5	139,5	139,5	139,5
FL	25,5	32	35	35	35	51	57	70	79,5	95,5	95,5	120,5
GL	28,5	32	47,5	47,5	47,5	74,5	74,5	89	116	171,5	171,5	232
GL 1	28,5	32	32	47,5	47,5	74,5	89	89	89	116	116	116
∅ HB	7,2	8,7	8,5	8,5	8,5	12	12	13,5	16,7	27	27	27
∅ HB 1	7,2	8,7	8,5	8,5	8,5	12	10,3	10,3	13,5	20	20	20
JL	20,5	25,5	39,5	39,5	39,5	65	65	76	100	151	151	209,5
JL 1	20,5	25,5	24	39,5	39,5	65	79,5	79,5	76	100	100	100
L	19	24	25,5	25,5	25,5	30	33,5	43	47,5	57	57	73
LE	20,5	25,5	19	35	35	57	79,5	79,5	55,5	100	100	100
LF	9,5	13	15,5	15,5	15,5	23,5	23,5	28	31,5	44,5	44,5	63,5
LF 1	9,5	13	14	16	16	24	28,5	28,5	28,5	35	35	35
PA	1,5	5	6,5	6,5	6,5	11	11	12,5	16	16	16	28,5
PA 1	1,5	5	5	6,5	6,5	11	16	16	12,5	12,5	12,5	12,5
RA	25,5	32	47,5	47,5	47,5	76	76	101,5	114,5	133,5	133,5	139,5
RA 1	25,5	32	32	47,5	47,5	76	89	89	102	120,5	120,5	120,5
RC	-	-	-	19	19	22	22	32	32	51	51	63,5
RC 1	-	-	-	19	19	22	22	22	32	38	38	38
SD	41,5	47,5	66,5	66,5	66,5	101,5	101,5	165	184	247,5	247,5	279,5
SD 1	41,5	47,5	51	67	67	102	114,5	114,5	165	206,5	206,5	206,5
TJ	-	-	-	-	-	-	-	32	38	57	57	70
TJ 1	-	-	-	-	-	-	-	32	32	41,5	41,5	41,5
UD	-	-	68,5	68,5	68,5	82,5	82,5	108	117,5	159	159	210
UD 1	-	-	49	68,5	68,5	82,5	-	-	108	-	-	-
XD	151	164,5	172	187,5	214,5	238	285,5	305	355,5	438	438	487,5



Rear Clevis Mounting Style 'D'

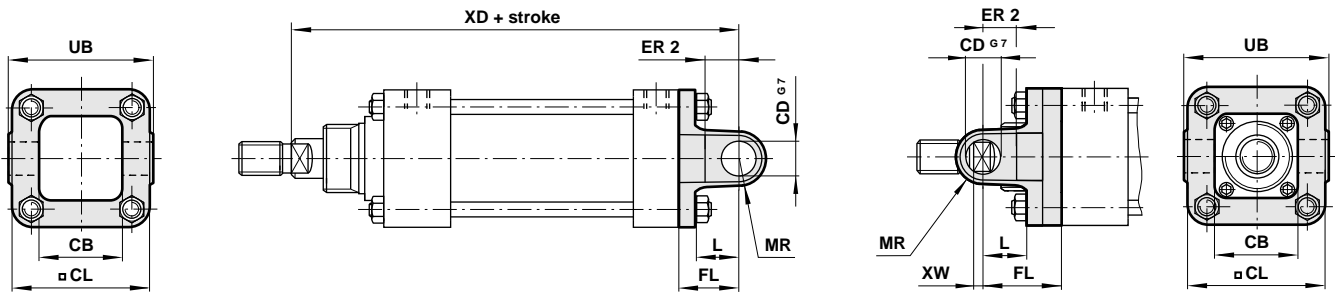

Front Clevis Mounting Style 'K'

Rear Eye Mounting Style 'R'

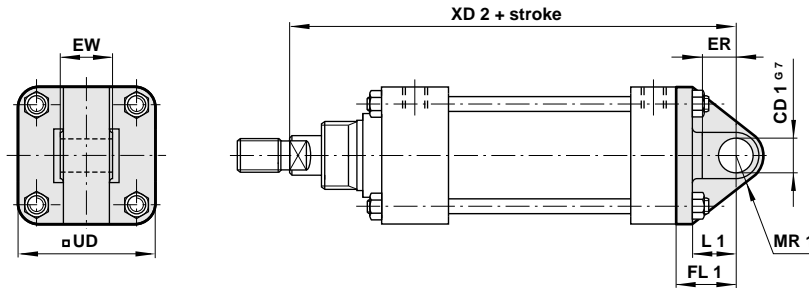

Universal Rear Eye Mounting Style 'UR'

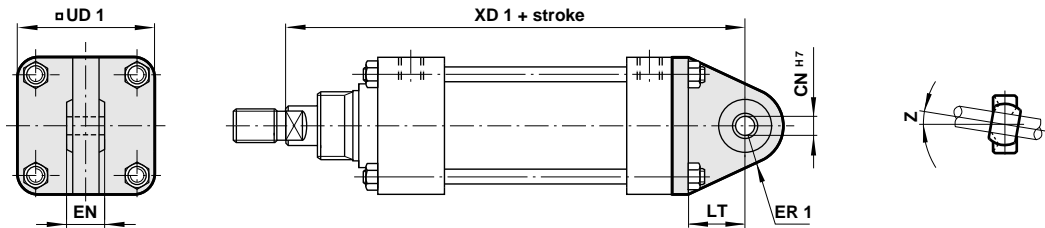

Model 'D'	M/P6937	M/P7457	M/P10228	M/P10311	M/P10229	QM/758	QM/759	QM/761	QM/762			
Model 'K'	M/P6937	M/P7457	QM/962	QM/964	QM/966	QM/758	QM/759	QM/761	QM/762			
Model 'R'	M/P11966	M/P11219	M/P10349	M/P10351	M/P10353	QM/763	QM/764	QM/765	QM/766	QM/767	QM/768	QM/769
Model 'UR'	QM/1161	QM/1162	QM/1163	QM/1164	QM/1165	QM/1166	QM/950/33	QM/960/33	QM/980/33			
Cylinder	9125	9175	920	925	930	940	950	960	980	9100	9120	9140
CB	25,4	34,9	34,9	42,9	44,5	69,9	92,1	106,4	122,2			
∅ CD G7	6	12	16	16	20	22	25	32	38			
∅ CD 1 G7	6	10	16	16	16	18	18	25	25	38	38	57
∅ CN H7	8	10	10	14	14	14	25	30	30			
CL	44,5	57	62,5	74	88	114,5	139,5	166,5	217,5			
EN	12	14	14	19	19	19	31	37	37			
ER	19	14,5	19	19	19	25,5	28,5	28,5	32	44,5	44,5	73
ER 1	16	18	18	26	26	26	36	43	48			
EW	19	19	38,1	38,1	38,1	44,5	44,5	63,5	63,5	101,6	101,6	127
FL	14,5	19	28,5	28,5	35	57	70	76	85,5			
FL 1	25,5	32	35	35	35	51	57	70	79,5	95,5	95,5	120,5
L	9,5	14,5	20,5	20,5	25,5	38	44,5	49	57	-	-	-
L 1	19	24	25,5	25,5	25,5	30	33,5	43	47,5	57	57	73
LT	19	26	27	26	26	30	36	39	42			
MR	6,5	10	13	13	14	19	24	29	38	-	-	-
MR 1	9	10	14	14	16	21	21	25,5	25,5	41	41	54
UB	-	-	-	-	-	122,5	152,5	181	237			
□ UD	45	57	62	74	87,5	112,5	138	165	217,5	268,5	319	375
□ UD 1	44,5	56,5	63	73	87,5	114	138	176	216			
XD	139,5	151,5	165,5	181	214,5	244,5	298,5	311	362			
XD 1	151,5	166,5	172	187,5	214,5	238						
XD	151	164,5	172	187,5	214,5	238	285,5	305	355,5	438	438	487,5
XW	22,5	18	7,5	16,5	6,5	7	13	6,5	0			
Z	13°	12°	12°	12°	12°	12°	12°	12°	12°			



Piston Rod Clevis Mounting Style 'F'

Universal Piston Rod Eye Mounting Style 'UF'

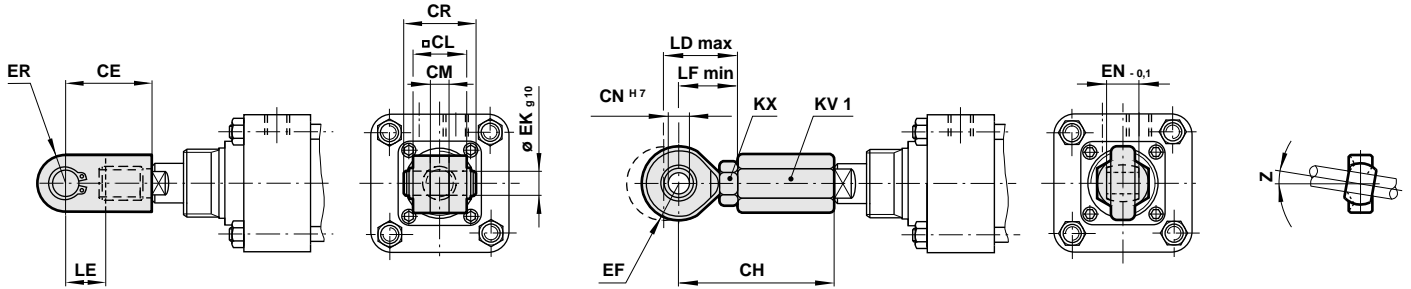

Central Trunnion Mounting Style 'H'

Note: These mountings are only supplied assembled complete with the cylinder. Unless otherwise specified, units will be supplied with dimension 'XV' plus half the stroke length. Grease nipple supplied as standard on cylinders 9175 to 9140.

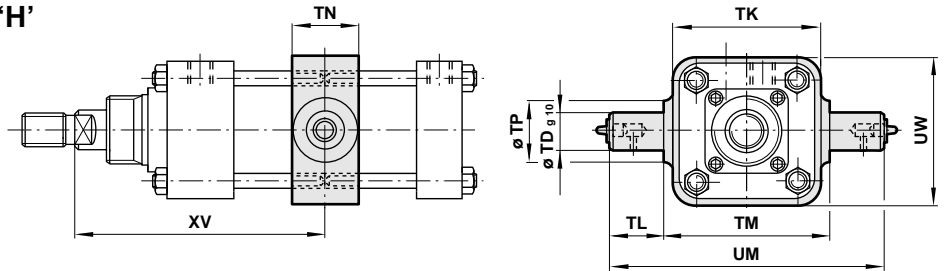

Adjustable Intermediate Trunnion Mounting Style 'UH'

Note: It is most important that the locking screws which secure the mounting to the tie rods are tightened to the torque figures shown in the above table. For maximum energy input, consult our Technical Service.

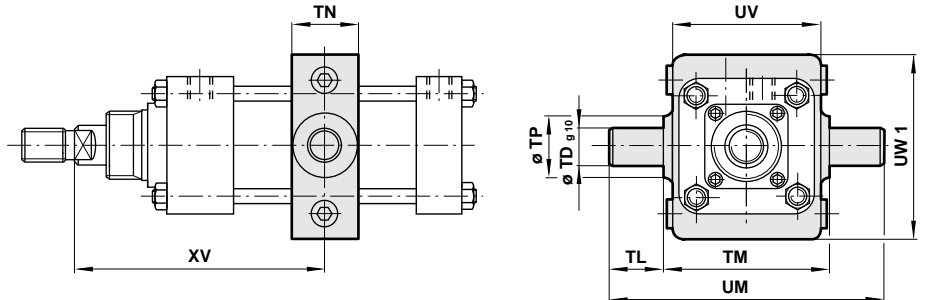

Model 'F'	QM/402	QM/404	QM/405	QM/407	QM/407	QM/408	QM/409	QM/409	QM/410	QM/411	QM/411	QM/411
Model 'H'	M/P14001	M/P11224	M/P8635	M/P8636	M/P8637	M/P8638	M/P8639	M/P8640	M/P8645	M/P8667	M/P8670	M/P11819
Model 'UF'	QM/1141	QM/1142	QM/1143	QM/1144	QM/1144	QM/1144						
Model 'UH'	QM/9125/40	QM/9175/40	QM/920/40	QM/925/40	QM/930/40	QM/940/40						
Cylinder	9125	9175	920	925	930	940	950	960	980	9100	9120	9140
CE	25,5	33,5	41,5	58,5	58,5	66,5	79,5	79,5	95,5	120,5	120,5	120,5
CH	59	74	74	96,5	96,5	101						
□ CL	12,5	19	25,5	38	38	44,5	51	51	63,5	76	76	76
CM	6,4	10	11	14	14	16	20	20	25	32	32	32
∅ CN H7	8	10	10	14	14	14						
CR	18	26	33	47	47	53	60	60	74	87	87	87
EF	13	15	15	19	19	19						
∅ EK g 10	6	10	12	16	16	18	22	22	25	32	32	32
EN -0.1	12	14	14	19	19	19						
ER	6,5	10	13	19	19	22	25	25	32	38	38	38
KV 1 (A/F)	14	17	22	32	32	32						
KX (A/F)	13	17	17	22	22	22						
LD max.	30	33	33	39	39	39						
LE	11	12,5	19	25,5	25,5	28,5	32	32	38	44,5	44,5	44,5
LF min.	24	28	28	36	36	36						
∅ TD g 10	12	16	18	22	25	32	38	38	45	65	75	90
TK	45	65	70	81	95	127	152	187	241,5	330	381	457
TL	17,5	24	25,5	32	38	41,5	51	51	54	76	76	101,5
TM	50,5	73	79,5	90,5	108	139,5	165	192	247,5	330	381	457
TN	20,5	25,5	32	38	38	44,5	51	51	70	76	89	101,5
∅ TP	18	22	29	35	38	44,5	51	51	64	114	127	140
UM	85,5	120,5	130	154	184	222,5	266,5	293,5	355,5	482,5	533,5	660,5
UV	45	57	70	81	95	127						
UW	45	65	70	81	95	127	152	187	245	318	368	432
UW 1	60	74	87	95	110	131						
XVmin	72,5	79	90,5	102	111,5	121,5	149,5	149,5	173	207	213,5	239
XVmax + stroke	93	94,5	97	108,5	125,5	130	162	168,5	189	245	238,5	255,5
Z	17	16	16	18	18	18						
Torque Nm	4	8	8	8	10	10						



Brackets for magnetically operated switches QM/33, QM/34 and QM/134

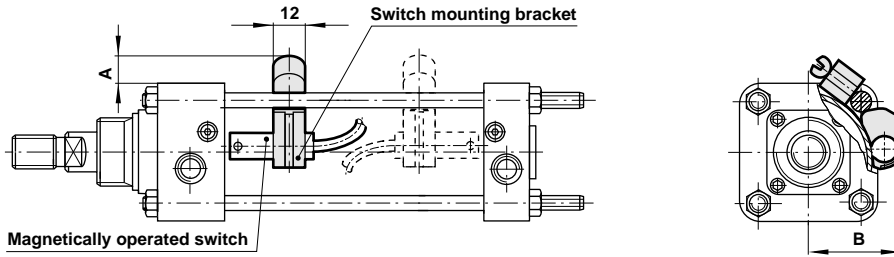

Model	QM/27/2/1	QM/27/2/1	QM/27/2/1	QM/27/2/1	QM/27/2/1	QM/27/2/1
ø inch	1 1/4	1 3/4	2	2 1/2	3	4
A	9	8	7	7	4	2
B	30,5	35,5	38	44,5	49,5	59

Brackets for magnetically operated switches QM/31, QM/32 and QM/132

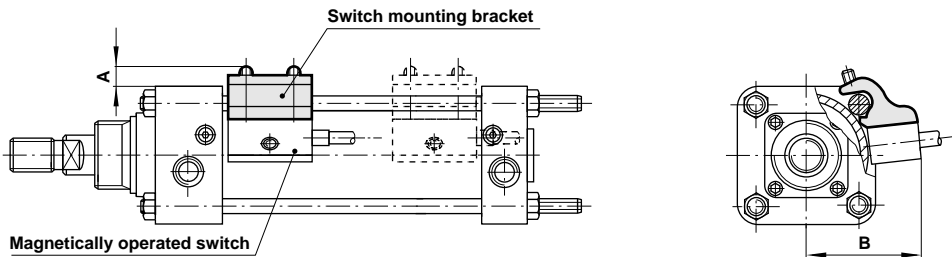

Model	QM/31/032/22	QM/31/032/22	QM/31/032/22	QM/31/032/22	QM/31/080/22	QM/31/080/22
ø inch	1 1/4	1 3/4	2	2 1/2	3	4
A	4,5	1,5	3,5	0,5	- 4,5	- 10
B	42	47	52	58	64	70

Piston Rod Bellows

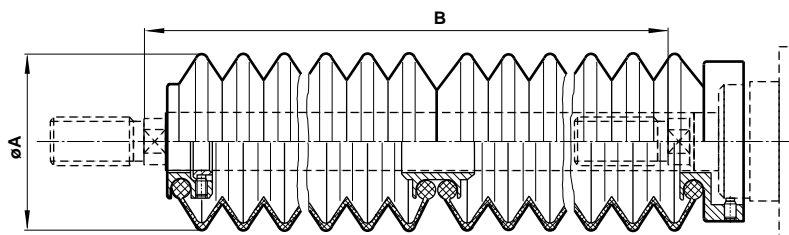

Model	Ø A	Maximum stroke per bellows	Piston rod extension B	
			first bellows	further bellows
RM/9125/G	40	60	30	25
RM/9175/G	63	145	50	32
RM/920/G	63	145	40	32
RM/925/G	80	250	50	45
RM/930/G	80	250	50	45
RM/940/G	80	250	50	45
RM/950/G	116	350	70	60
RM/960/G	116	350	70	60
RM/980/G	116	350	70	60
RM/9100/G	143	500	110	100
RM/9120/G	143	500	110	100



Spares

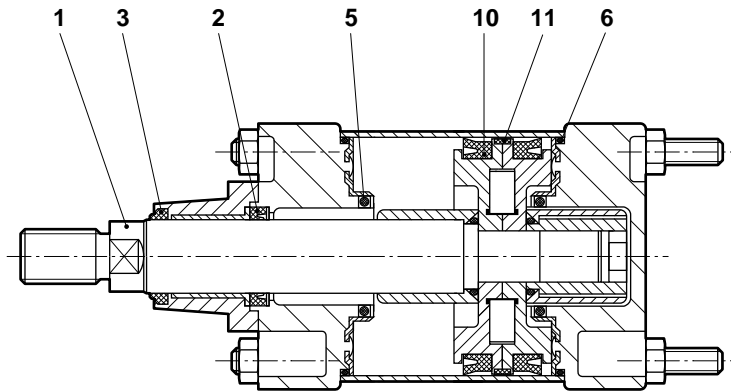

Model	Spares kit	Comprising:			Piston rod Item 1
		Item	Description	Quantity	
RM/9125, RM/9125/M	QM/9125/00	2	Piston rod seal	1	RM/P35745/*
RM/9175, RM/9175/M	QM/9175/00	3	Wiper seal	1	RM/P35795/*
RM/920, RM/920/M	QM/920/00	5	O-Ring or seal	2	RM/P35721/*
RM/925, RM/925/M	QM/925/00	6	O-Ring or seal	2	RM/P35811/*
RM/930, RM/930/M	QM/930/00	10	Piston seal	2	RM/P35819/*
RM/940, RM/940/M	QM/940/00	11	Wear ring (9100 to 9140)	1	RM/P35827/*
RM/950	QM/950/00				RM/P9951/*
RM/960	QM/960/00				RM/P9951/*
RM/980	QM/980/00				RM/P10298/*
RM/9100	QM/9100/00				RM/P10663/*
RM/9120	QM/9120/00				RM/P10663/*
RM/9140	QM/9140/00				RM/P11771/*

* Insert stroke length

Note: Please quote the cylinder type number when ordering spare parts

Warning

These products are intended for use in industrial compressed air systems only. Do not use these products where pressures and temperatures can exceed those listed under 'Technical Data'.

Before using these products with fluids other than those specified, for non-industrial applications, life-support systems, or other applications not within published specifications, consult NORGREN.

Through misuse, age, or malfunction, components used in fluid power systems can fail in various modes.

The system designer is warned to consider the failure modes of all component parts used in fluid power systems and to provide adequate safeguards to prevent personal injury or damage to equipment in the event of such failure.

System designers must provide a warning to end users in the system instructional manual if protection against a failure mode cannot be adequately provided.

System designers and end users are cautioned to review specific warnings found in instruction sheets packed and shipped with these products.