

Mains Power Cord

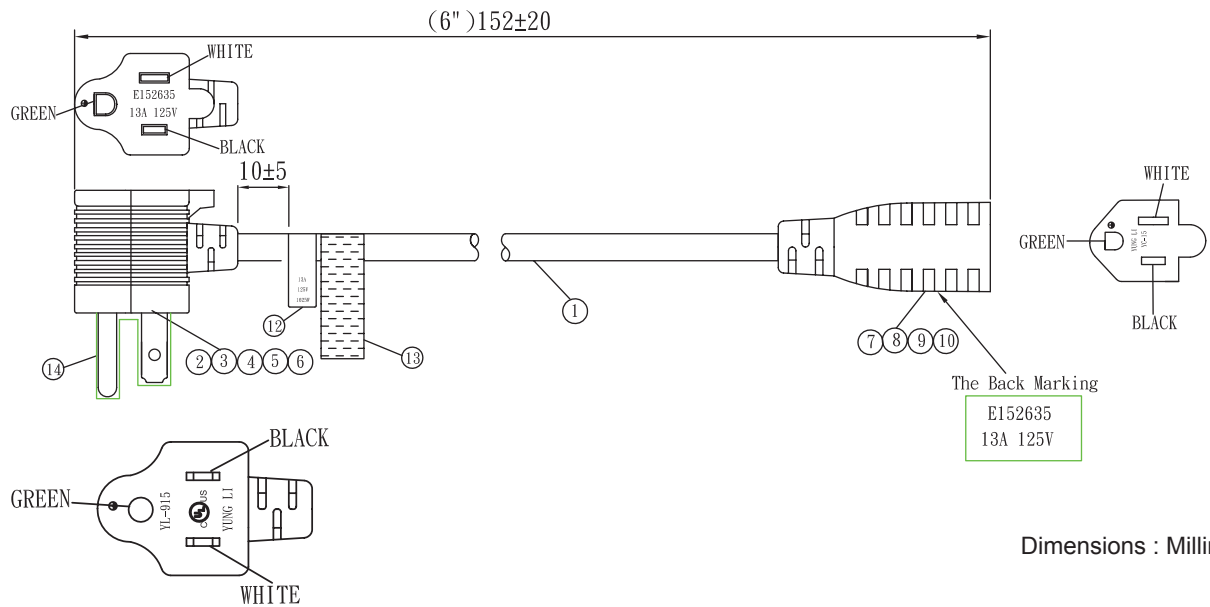

No.	Specification	Qty.
1	SJT 16/3C 105°C Black	1PC
2	YL-915 PVC Plastic: 35P Black	32g/PC
3	D-Type Ter: 97575	2PCS
4	TER: 5475	1PC
5	YL-915 Inner Body	1PC
6	YL-915 TER S3419	2PCS
7	YC-15 PVC Plastic: 35P Black	18g/PC

No.	Specification	Qty.
8	"D" Ter: 98575	1PC
9	YC-21 Inner Body	1PC
10	TER: XD0P001380	2PCS
11	Mini Tie: L = 130 Black	1PC
12	UL Label: 13A 125V	1PC
13	Label: 230×36mm	1PC
14	Sleeve	1PC

Part Number Table

Description	Part Number
Mains Power Cord, 15 A, 125 VAC	YL-915/YC-15