

Description

The 8Axxxx 48QFN EVK is designed to help customers evaluate IDT ClockMatrix devices. This document discusses the following about the EVK:

- Introduces the board and its power supply and jumper settings
- Describes the input and output connectors for normal operation
- Explains how to bring up the board using the Timing Commander software GUI
- Discusses how to configure and program the board to generate standard-compliant frequencies

Requirements

- IDT Timing Commander Software Installed (available at www.idt.com/timingcommander)
- ClockMatrix GUI (available at www.idt.com/clockmatrix)
- USB 2.0 or USB 3.0 interface
- Windows XP SP3 or later
- Processor: Minimum 1GHz
- Memory: Minimum 512MB; recommended 1GB
- Available disk space: Minimum 600MB (1.5GB 64-bit); recommended 1GB (2GB 64-bit)
- Network access during installation if the .NET framework is not currently installed on the system

Kit Contents

- 8A34xxx 48QFN Evaluation Board
- USB Type A cable

8A3xxxx 48QFN EVK Board



Important Notes

Disclaimer

Integrated Device Technology, Inc. and its affiliated companies (herein referred to as "IDT") shall not be liable for any damages arising out of defects resulting from

- (i) delivered hardware or software
- (ii) non-observance of instructions contained in this manual and in any other documentation provided to user, or
- (iii) misuse, abuse, use under abnormal conditions, or alteration by anyone other than IDT.

TO THE EXTENT PERMITTED BY LAW, IDT HEREBY EXPRESSLY DISCLAIMS AND USER EXPRESSLY WAIVES ANY AND ALL WARRANTIES, WHETHER EXPRESS, IMPLIED, OR STATUTORY, INCLUDING, WITHOUT LIMITATION, IMPLIED WARRANTIES OF MERCHANTABILITY AND OF FITNESS FOR A PARTICULAR PURPOSE, STATUTORY WARRANTY OF NON-INFRINGEMENT, AND ANY OTHER WARRANTY THAT MAY ARISE BY REASON OF USAGE OF TRADE, CUSTOM, OR COURSE OF DEALING.



Important Equipment Warning: Ensure the correct connection of all cables. Supplying the board using the wrong polarity could result in damage to the board and/or the equipment. Check that all jumpers have been removed from the board before applying power.

Contents

1.	Usage Guide.....	4
1.1	Board Overview	4
1.2	Board Power Supply	5
1.3	Voltage Selection Jumpers	5
1.4	GPIO Switches, LEDs, and Test Points	6
1.5	USB Jack.....	7
1.6	Onboard EEPROM.....	7
1.7	I ² C/SPI Auxiliary Path Specifications.....	7
2.	Working with Timing Commander™ for Progaming/Configuration.....	8
2.1	Default Operation	8
2.2	Using Timing Commander to Control the Board.....	10
2.3	Output Terminations and Rework to Take 1PPS Input.....	16
3.	How to Upgrade the Firmware.....	17
3.1	Upload Firmware to the RAM	17
3.2	Upload Firmware into the EEPROM.....	19
3.3	Verify the EEPROM Programming	20
4.	Schematics	21
5.	Ordering Information.....	21
6.	Revision History.....	21

List of Figures

Figure 1. Overview of 48QFN ClockMatrix Evaluation Board	4
Figure 2. Example of Voltage Jumpers.....	5
Figure 3. GPIO Setting and Status Display Area	7
Figure 4. Board Setting for Default Operation	9
Figure 5. Starting Up Timing Commander GUI.....	10
Figure 6. Selecting 8A34001 using Personality File v4.6.....	11
Figure 7. Timing Commander GUI with a Settings File Opened.....	12
Figure 8. Setting I ² C for Connecting the Board with GUI.....	13
Figure 9. A Green Band appears when a Valid Connection is Made.....	13
Figure 10. Firmware Version Mismatch Warning Message	14
Figure 11. Reading Firmware Version	14
Figure 12. Read Firmware Version of ClockMatrix Chip.....	15
Figure 13. AC Coupling and Terminations for Input Clock.....	16
Figure 14. Configuring CLK0 as CMOS to Receive a 1PPS Input.....	16

List of Tables

Table 1. GPIO Settings.....	6
Table 2. EEPROM I ² C Connections	7
Table 3. I ² C/SPI Path Connections.....	7

1. Usage Guide

1.1 Board Overview

The following diagram identifies various components of the board: input and output SMA connectors, power supply jacks, and some jumper settings necessary for the board operations.

Figure 1. Overview of 48QFN ClockMatrix Evaluation Board

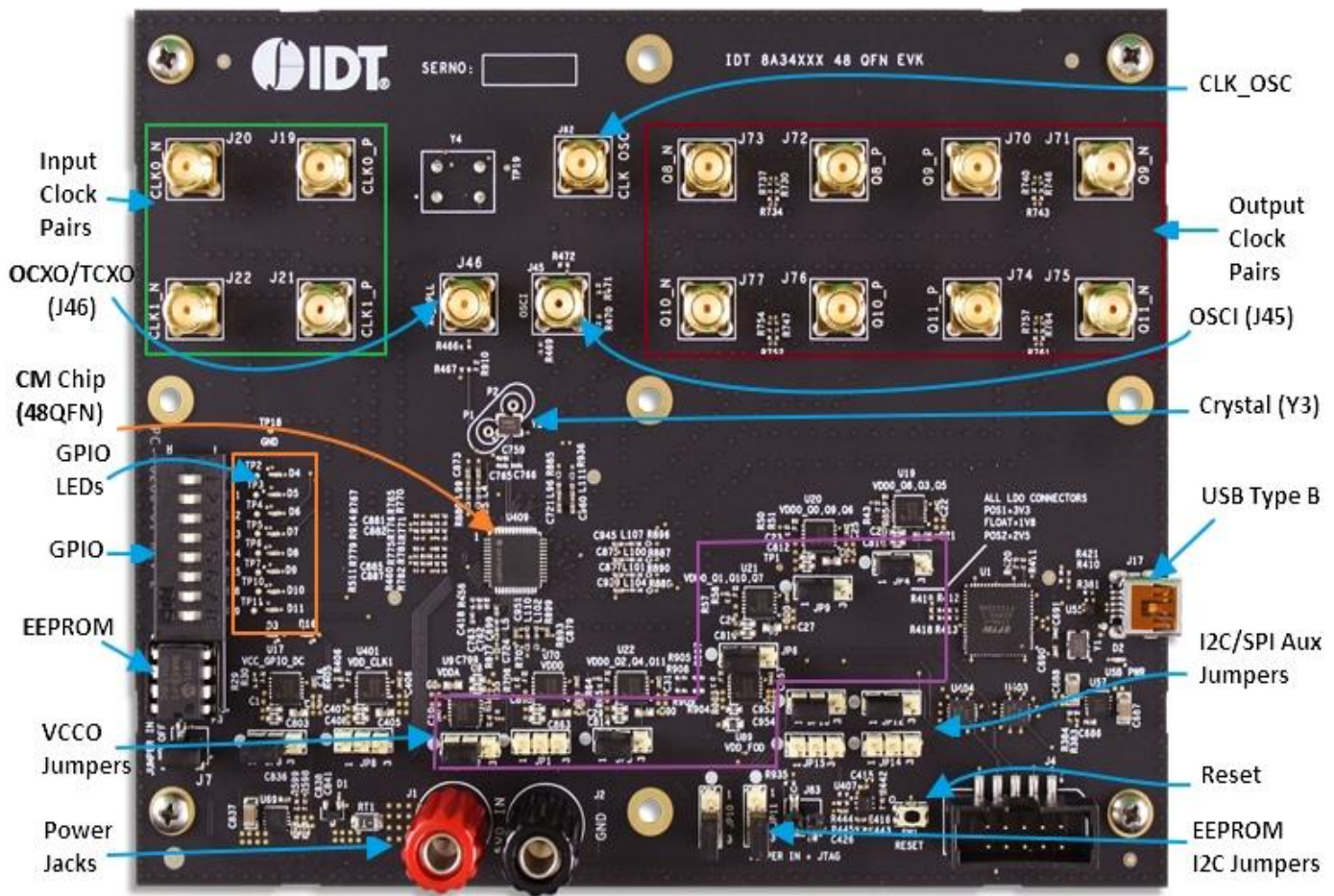

Detailed descriptions of the board are as follows.

- Input SMA Connectors – There are two differential inputs labeled CLK0/nCLK0–CLK1/nCLK1. Each input clock can be configured differentially (LVDS, PECL 2.5V, and PECL 3.3V) or in single-ended format (CMOS).
- Output SMA Connectors – There are four outputs labeled as Q8/nQ8–Q11/nQ11. Each output clock can be configured differentially (LVDS, LVPECL, or user-defined amplitude), or in single-ended format (LVCMOS – in-phase or out-of-phase)
- GPIO switch, LEDs, and test points – There are eight GPIOs available. Each GPIO can be set a “low” or “high” level (if input) or displayed with an LED (if output). Some GPIOs are used to set the chip in a certain working condition on power-up. For more information, see GPIO Switches, LEDs, and Test Points.
- USB connector – A USB mini-connector connects the evaluation board to a PC for GUI communications. No power is drawn from the USB connector other than to power the FTDI USB chip.

- VCCO voltage selection jumpers – Each output voltage can be individually supplied with 1.8V, 2.5V, or 3.3V. These jumpers are used to select the voltage for the output voltages.
- Reset button – A small button is used to reset the board.
- OSCI Input connector – An SMA connector, J45, can optionally supply a clock signal to overdrive the crystal.
- OCXO/TCXO reference – An SMA connector, J46, can supply a local OCXO/TCXO reference as an optional reference for System DPLL.
- Crystal – A crystal of various frequencies must be present for board operations. A 3225 footprint is provided for SMT crystals. For easy plug-in of a canned crystal, two through holes are also available.
- EEPROM – An SO-8 socket is provided to hold an EEPROM device of compatible package. EEPROM is used to store firmware and customer configuration data, if needed.

1.2 Board Power Supply

The board uses a single +5V supply for its power supplies. When running the board, set the bench power supply at 5V/2A. The red jack (J1) is positive; the black jack (J2) is the ground.

Multiple LDOs are used to generate 3.3V, 2.5V, and 1.8V from the +5V supply.

1.3 Voltage Selection Jumpers

There are nine headers/jumpers to select different voltages for different functional blocks of the chip. Each header is labeled pin 1 and pin 3 – jumping pin 1 and pin 2 will select 3.3V; jumping pin 2 and pin 3 will select 2.5V; no jumper will have 1.8V.

Please see the following example for JP4 and JP9 – JP4 will select 2.5V; JP9 will select 3.3V.

Figure 2. Example of Voltage Jumpers

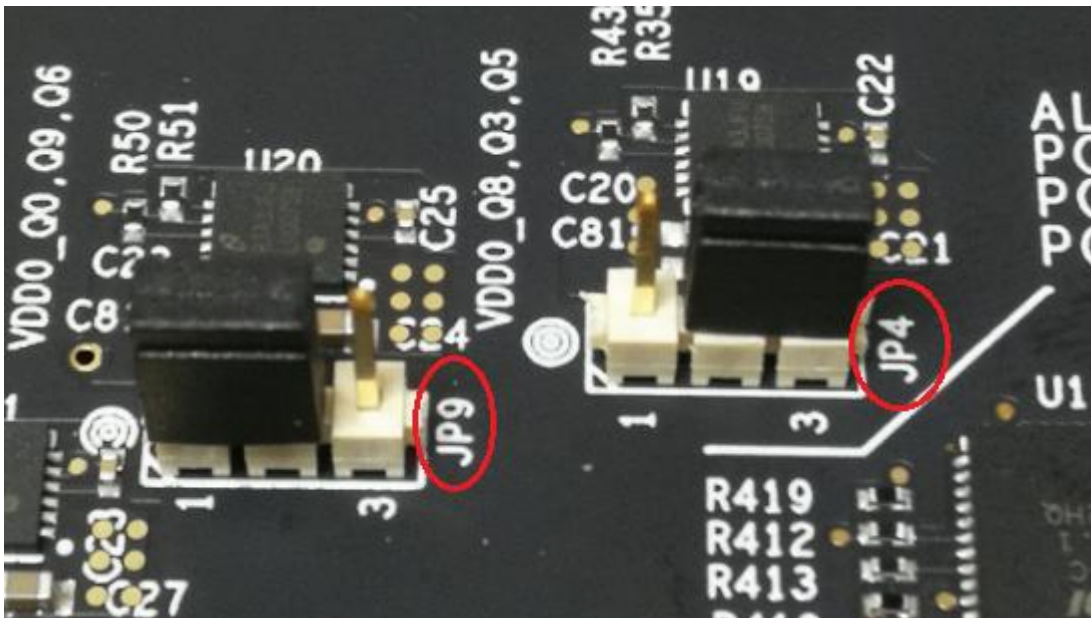

The following list shows which header/jumper is used to select what voltage:

- JP1 – VDDD
- JP2 – VDDA
- JP3 – VCC_GPIO_DC
- JP4 – VDDO_Q8_3_5
- JP5 – VDDO_Q2_4_11
- JP6 – VDDO_1_10_7
- JP7 – VDD_CLK0
- JP8 – VDD_CLK1
- JP9 – VDDO_Q0_9_6



Important Equipment Warning: VDD_FOD voltage is selected by resistors R908 and R909. In order to prevent damage to the device, both R908 and R909 should not be stuffed, in which case VDD_FOD = 1.8V.

1.4 GPIO Switches, LEDs, and Test Points

An 8-bit dip switch sets the logic levels for eight GPIOs. The following table shows the GPIO levels for each setting and the corresponding LED state.

Table 1. GPIO Settings

Dip Switch Position	GPIO Logic Level	LED
Left	Low	On
Center	High if GPIO is configured as Input High or Low according to the GPIO output setting	High if GPIO is configured as Input High or Low according to the GPIO output setting
Right	High	Off

Please see the picture and labels in Figure 3.

When the GPIOs are configured as outputs (such as User-Controlled or LOL indicator), the dip switch for the corresponding GPIO should be placed in the center position. The LED will indicate the state of the GPIO.

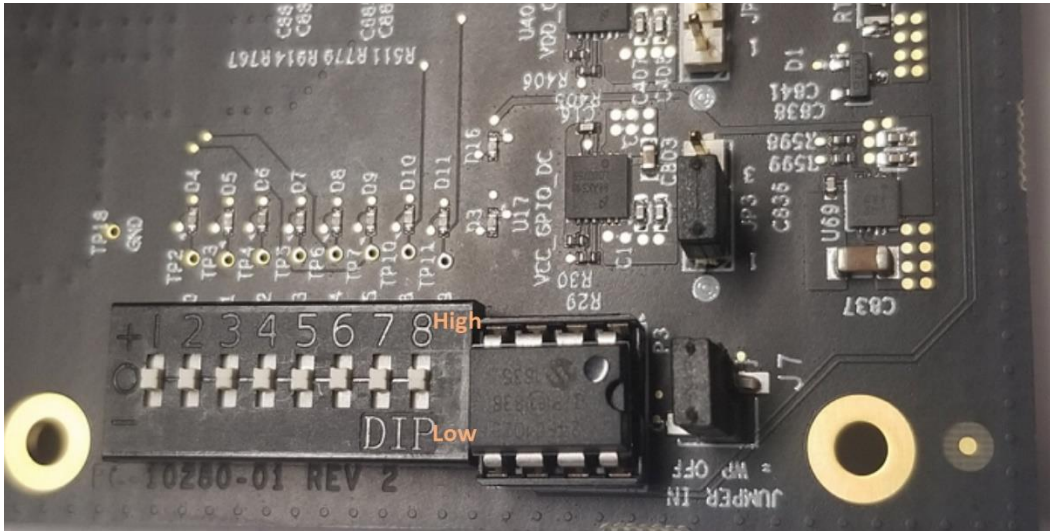
Figure 3. GPIO Setting and Status Display Area

1.5 USB Jack

The board has a USB mini-connector. The other end of the USB cable is a USB Type A connector going to a PC.

1.6 Onboard EEPROM

An onboard EEPROM is used to store device firmware and/or customer's configuration data. There are two headers/jumpers, JP10 and JP11, used to select the I²C communication paths for the EEPROM.

Table 2. EEPROM I²C Connections

	JP10/JP11	JP10/JP11
Jumper Position	Both Pin 1 and 2	Both Pin 2 and 3
EEPROM I ² C Path	FDTI and EEPROM	EEPROM and CM Chip

1.7 I²C/SPI Auxiliary Path Specifications

I²C and SPI connections can be configured using onboard jumpers. There are four headers/jumpers that control the auxiliary serial stream signals.

Table 3. I²C/SPI Path Connections

	JP12/JP13	JP12/JP13	JP14/JP15	JP14/JP15
Jumper Position	Pin 1 and 2	Pin 2 and 3	Pin 1 and 2	Pin 2 and 3
CM Chip Serial Port Path	SCLK/SDA Connected to on-board FTDI I ² C Chip (Default)	SCLK/SDA Connected to J4 for external I ² C/SPI controller use	NONE	SDI/nCS Connected to J4 for external I ² C/SPI controller use

2. Working with Timing Commander™ for Programming/Configuration

The following sections are best cross-referenced with the *ClockMatrix GUI Step-by-Step User Guide* which is available on www.idt.com.

2.1 Default Operation

The board can operate off an EEPROM that has stored all information including firmware and a default configuration data. A default operation provides a sanity check on the board before running the board through the IDT Timing Commander. Please set the board in the following default conditions (see Figure 4 for jumper and switch positions).

- Set all the GPIOs to the center position. This will ensure that GPIO8 and GPIO9 are high and that the serial port is configured for I²C 1-byte addressing.
- VDDA = 3.3V, VCC_GPIO_DC = 3.3V, and VDDO_Qx = 3.3V
- Crystal frequency = 50MHz
- CLK0 = 25MHz
- EEPROM is connected to ClockMatrix chip through an I²C bus by jumping Pin 2 and 3 of JP10 and JP11

With the above default conditions ready, connect the board to the PC using a USB type A to USB mini cable, and power up the board using a single +5V supply. On power-up, the ClockMatrix chip will read its firmware and configuration data from EEPROM and update all registers. When this process is completed, the following frequencies are available:

Q0 = 122.88MHz

Q1 = 122.88MHz

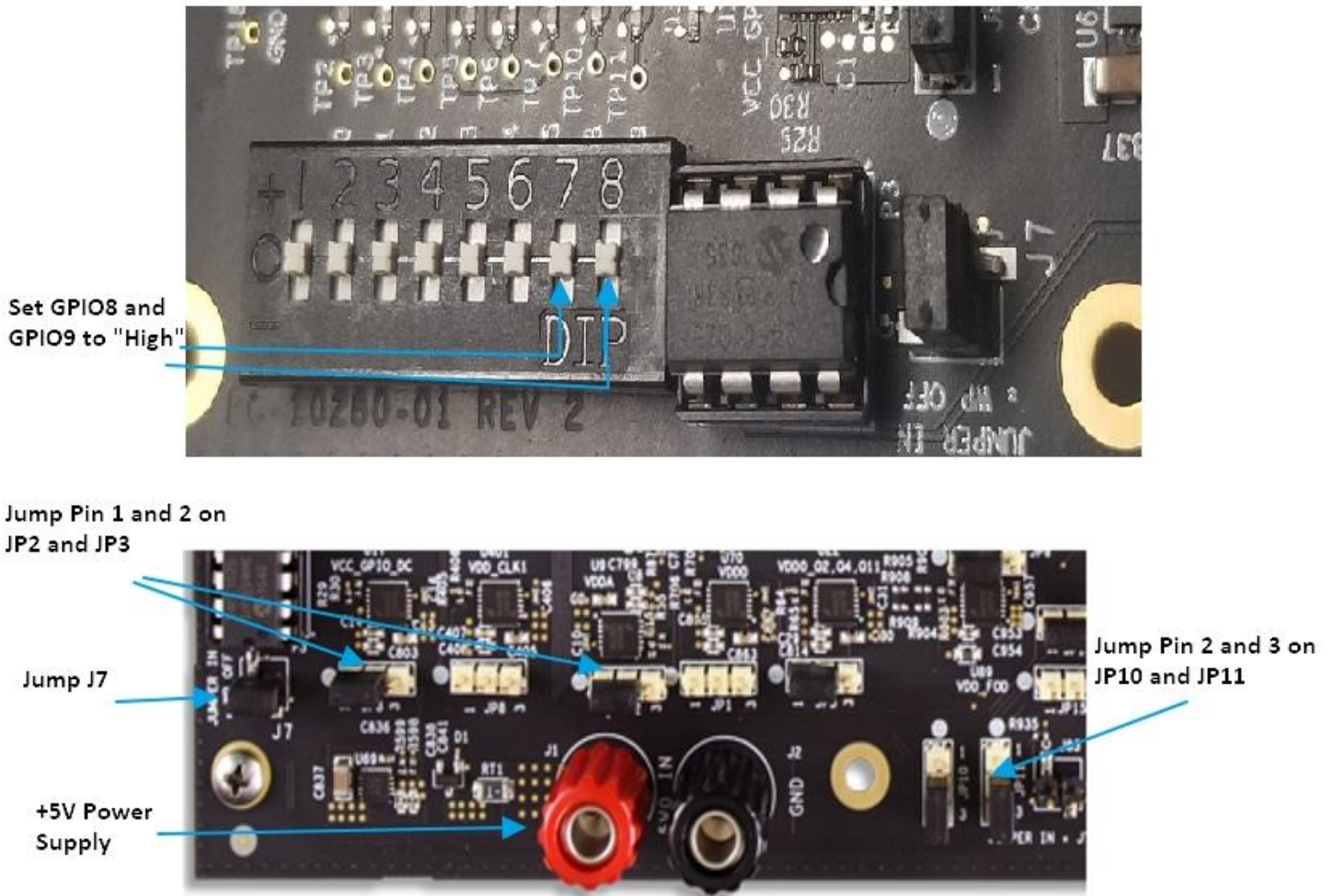
Figure 4. Board Setting for Default Operation

Important Equipment Warning: In order to set GPIO8 and GPIO9 to “High”, the switches for GPIO8 and GPIO9 must be set either to the “+” (high) position or the center position.

2.2 Using Timing Commander to Control the Board

Once the default operation is successful, complete the following steps to configure and program the ClockMatrix device per your specific application requirements using Timing Commander GUI tools:

1. Power up the board and set the main serial port in I²C mode by GPIO9 = "high". Set GPIO8 = "High". Connect the board to the PC.
2. Start the Timing Commander software. You will see options of "New Setting File" and "Open Setting file". For a new configuration, select "New Setting File".

Figure 5. Starting Up Timing Commander GUI

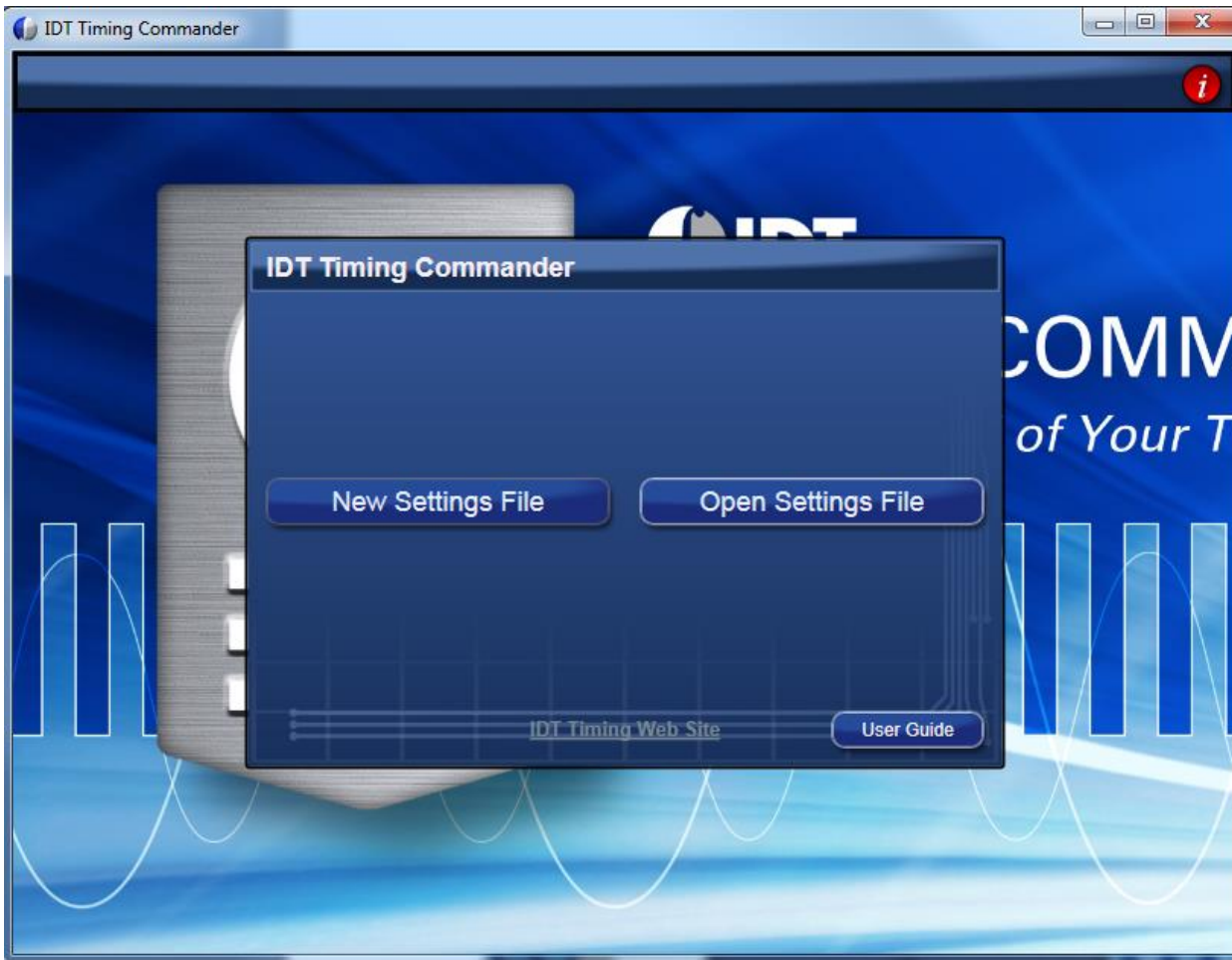

3. After selecting "New Settings File", a device selection window will pop up. In the window, choose the intended device in the list (in this example, 8A34001 is selected). Click the button at the lower right corner of the window (red circle) to browse and select the correct personality file (in this example, personality v4.6 is selected). Click OK.

Figure 6. Selecting 8A34001 using Personality File v4.6

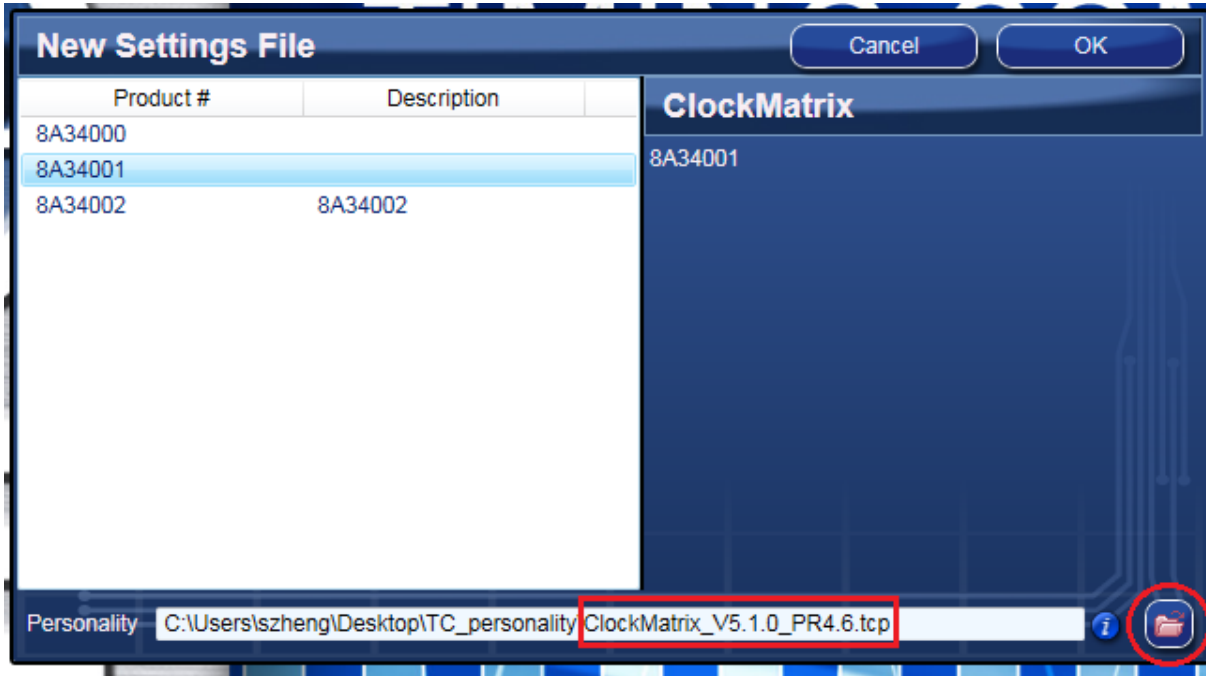

- The GUI window with the 8A34001 block diagram will open for configurations; or if “Open Settings File” is selected in Step 3, you will be prompted to browse and select an existing .tcs file and the personality file. When the configuration file is open, all configured values will be displayed (see Figure 7).

Figure 7. Timing Commander GUI with a Settings File Opened



- In order to connect the board with Timing Commander (PC), click the button (red circle) at the up-right corner of the GUI to set up the communication protocols (see Figure 7).

After I²C and one-byte addressing are selected, click OK to close the window.

Figure 8. Setting I²C for Connecting the Board with GUI

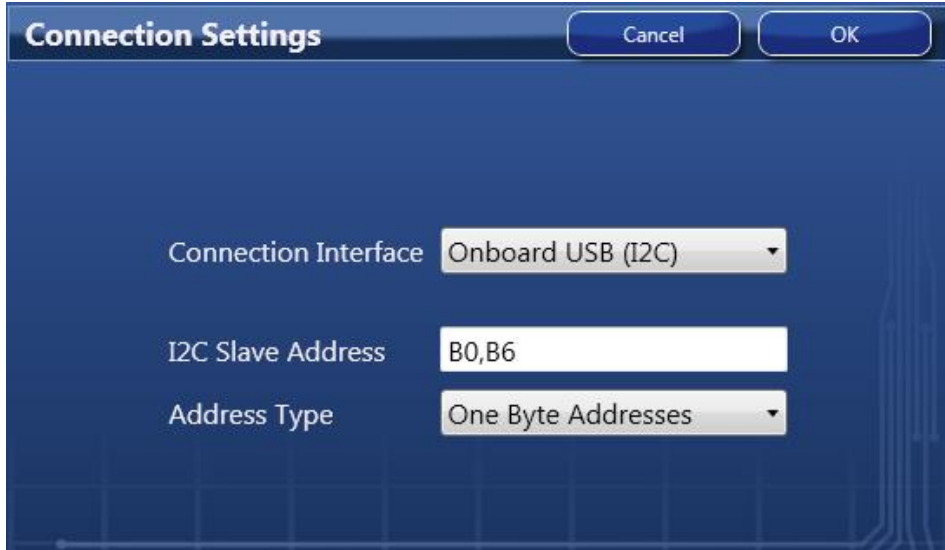

- Click on the chip symbol at the upper-right corner to initiate the connection. The connection is valid when a green band appears at the upper-right corner of the window, as shown below.

Figure 9. A Green Band appears when a Valid Connection is Made

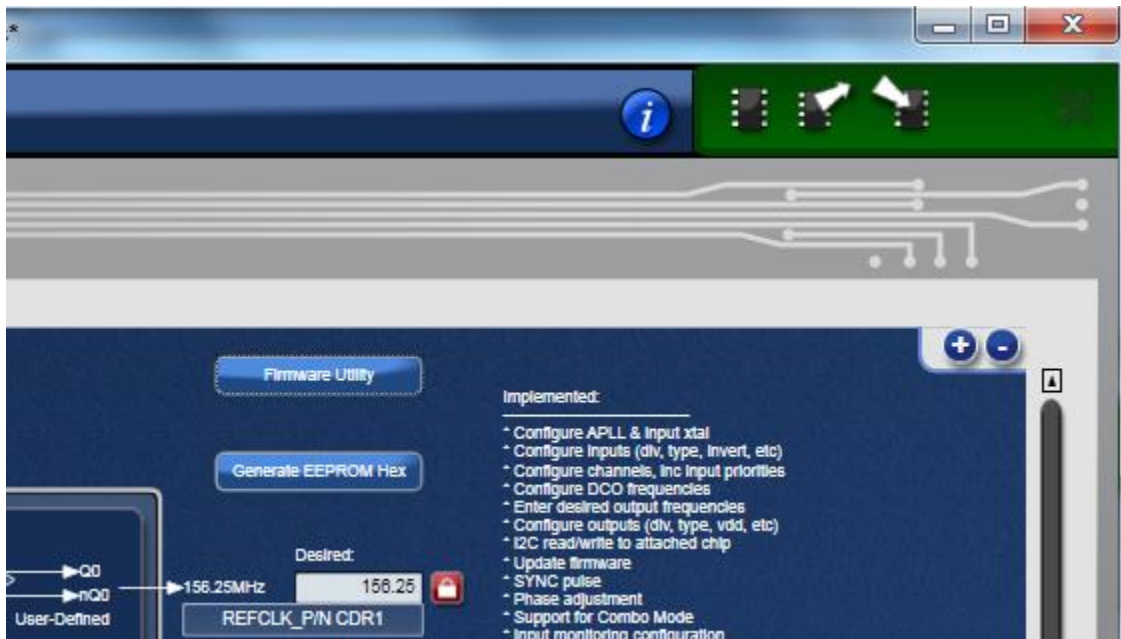

- If ClockMatrix chip's firmware, or firmware loaded from EEPROM, has a different version from that in the Personality file, a firmware version mismatch warning message will appear. Click "Close" button to close the message window and a connection is made.

Figure 10. Firmware Version Mismatch Warning Message



- Once the connection is made, the firmware version can be read within the GUI. Click the "Firmware Utility" button to bring up the Firmware Utility window, as shown below.

Figure 11. Reading Firmware Version



9. Within the Firmware Utility window, click the “Get Firmware Version” button to read the firmware version.

Figure 12. Read Firmware Version of ClockMatrix Chip

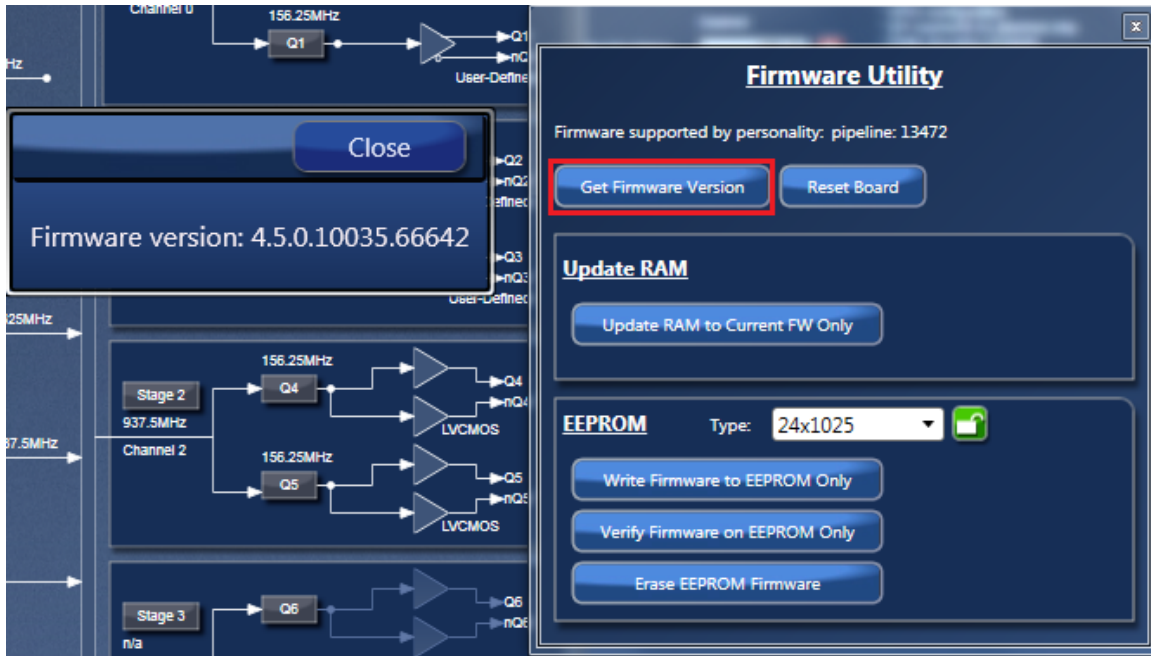

10. In the case where the firmware version mismatches each other, a firmware upgrade is necessary to update the chip’s firmware. To do so, complete the steps in How to Upgrade the Firmware to update the chip’s firmware.

2.3 Output Terminations and Rework to Take 1PPS Input

All outputs are terminated per LVDS with a 100Ω resistor across the output pair. When the output is configured as PECL2.5 and PECL3.3 or user-defined differential, the output clock will still be switching. The amplitude may be different from expected until the hardware termination matches the signaling type configured for the output.

The following rework must be implemented in order to support a 1PPS input clock. All input clocks for this board are ac-coupled and terminated as in the following figure.

Figure 13. AC Coupling and Terminations for Input Clock

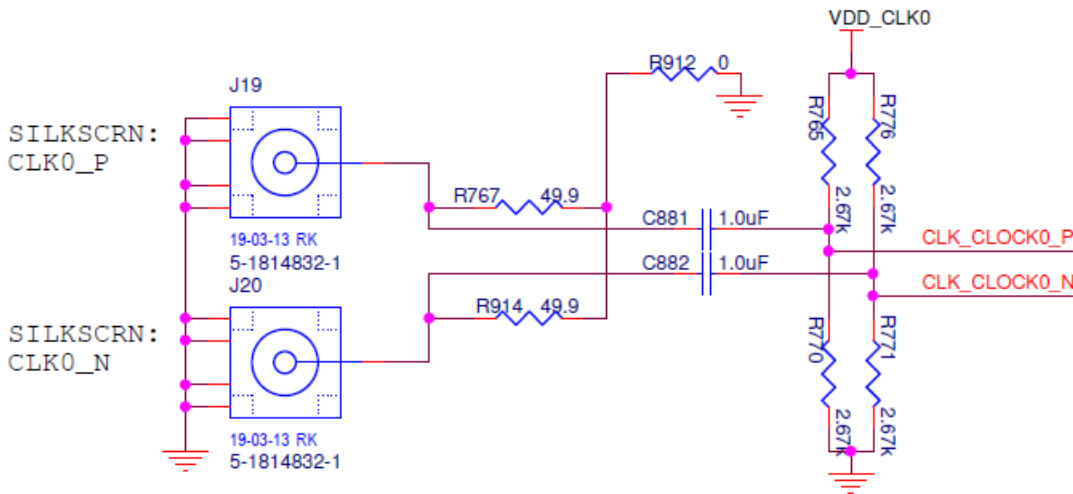

For a 1PPS input, a single-ended input with DC-coupling is recommended. As such, the populated AC-coupling capacitor must be removed and the input must be configured as LVCMOS, not differential.

1. In Figure 13, to make CLK0 supportive of 1PPS input, first configure CLK0 as LVCMOS in Timing Commander (see Figure 14).

Figure 14. Configuring CLK0 as CMOS to Receive a 1PPS Input

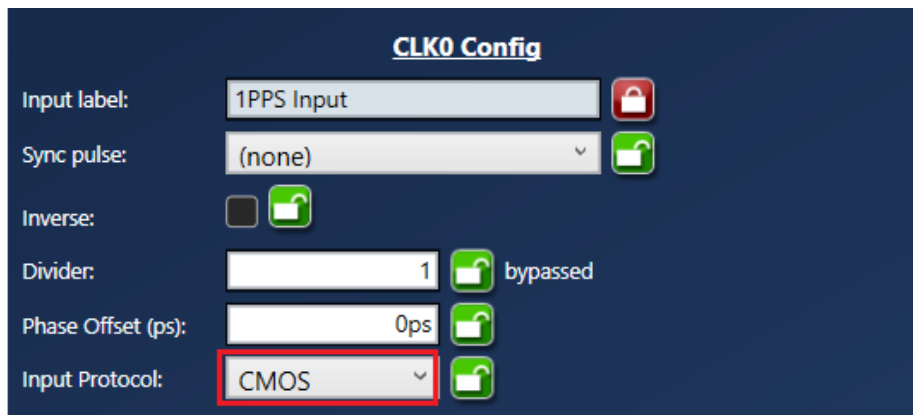

2. Once in LVCMOS mode, CLK0_P and CLK0_N will be two separate LVCMOS inputs instead of a differential pair. To make CLK0_P receive a 1PPS input, replace C881 with a 0Ω resistor; and at the same time, remove R765 and R770.

3. How to Upgrade the Firmware

3.1 Upload Firmware to the RAM

1. Connect to the EVK board.
2. Power up the board with no EEPROM present. This ensures the firmware is 4.0.2.7017, as displayed in the figure.
3. The GUI will indicate that the firmware on the chip does not match the GUI firmware. Press “Close”.



4. Open the “Firmware Utility” window by clicking on the button as follows.



5. Update the Firmware first. Press “Update RAM to Current FW Only”.

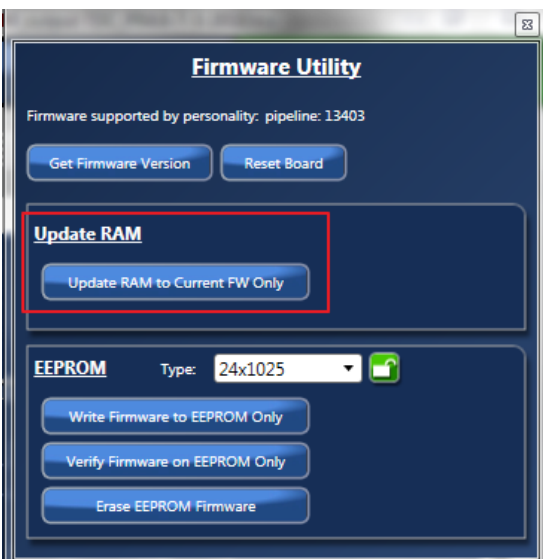

6. In the next window, press “Yes” and wait around 3-4 minutes.

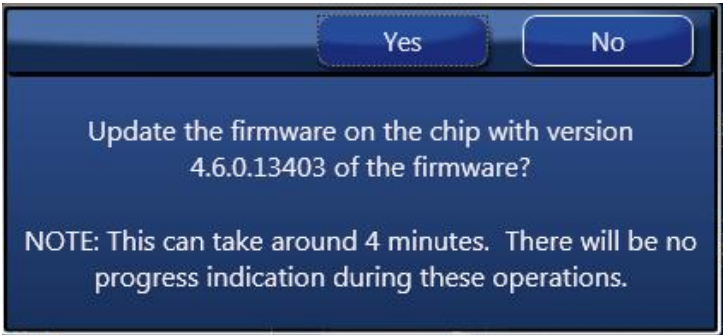

7. Once the firmware is updated, the following window will indicate a successful update. Click “Close”.

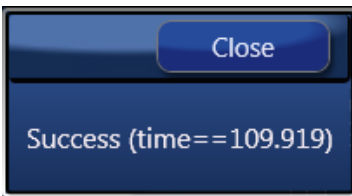

8. Press “Get Firmware Version” to verify that the RAM was updated correctly, then click “Close”.

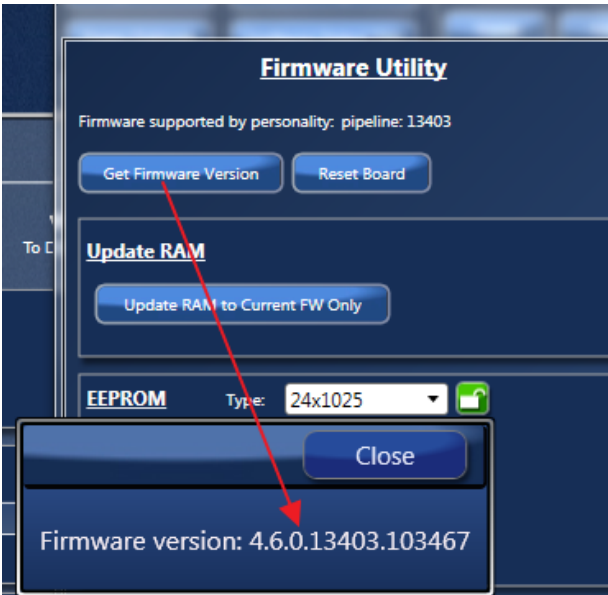

3.2 Upload Firmware into the EEPROM

1. Once the firmware has been updated to the chip (steps 1 to 8), install the EEPROM on the EVK board.
2. Press "Write Firmware to EEPROM Only".

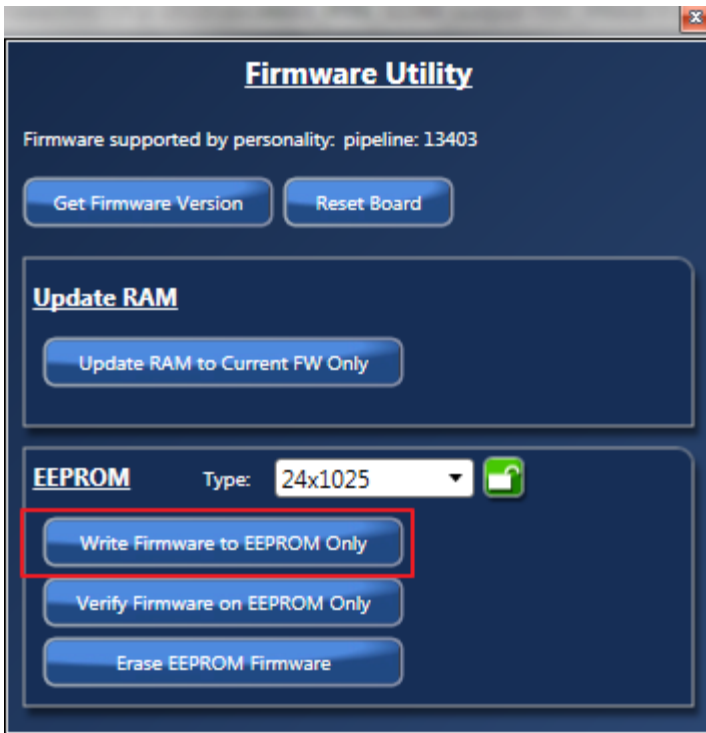

3. In the next window, press "Yes".

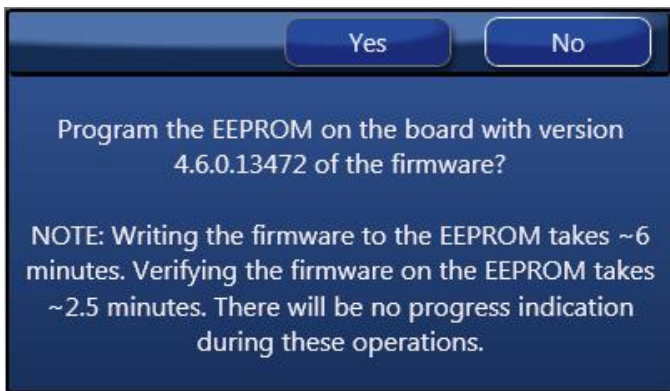

- When asked to "Verify" the EEPROM, press "No".

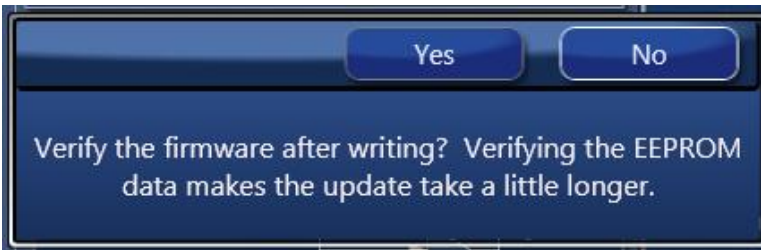

- In the next window, press "Close" to start the EEPROM write.



- Wait about 5 minutes for the EEPROM write to complete. Click "Close" in the following window.

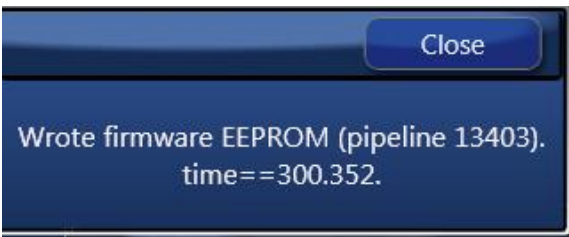

3.3 Verify the EEPROM Programming

- Power cycle the board.
- Disconnect and reconnect to the chip.
- Read back the firmware version to ensure it is correct (see steps 3 to 7).

4. Schematics

Please see the schematics located at the end of this document.

5. Ordering Information

Orderable Part Number	Description
8A34043-EVK	8A3xxxx 48QFN Evaluation Kit

6. Revision History

Revision Date	Description of Change
February 15, 2019	Initial release.



Corporate Headquarters

6024 Silver Creek Valley Road
San Jose, CA 95138
www.IDT.com

Sales

1-800-345-7015 or 408-284-8200
Fax: 408-284-2775
www.IDT.com/go/sales

Tech Support

www.IDT.com/go/support

DISCLAIMER Integrated Device Technology, Inc. (IDT) and its affiliated companies (herein referred to as "IDT") reserve the right to modify the products and/or specifications described herein at any time, without notice, at IDT's sole discretion. Performance specifications and operating parameters of the described products are determined in an independent state and are not guaranteed to perform the same way when installed in customer products. The information contained herein is provided without representation or warranty of any kind, whether express or implied, including, but not limited to, the suitability of IDT's products for any particular purpose, an implied warranty of merchantability, or non-infringement of the intellectual property rights of others. This document is presented only as a guide and does not convey any license under intellectual property rights of IDT or any third parties.

IDT's products are not intended for use in applications involving extreme environmental conditions or in life support systems or similar devices where the failure or malfunction of an IDT product can be reasonably expected to significantly affect the health or safety of users. Anyone using an IDT product in such a manner does so at their own risk, absent an express, written agreement by IDT.

Integrated Device Technology, IDT and the IDT logo are trademarks or registered trademarks of IDT and its subsidiaries in the United States and other countries. Other trademarks used herein are the property of IDT or their respective third party owners. For datasheet type definitions and a glossary of common terms, visit www.idt.com/go/glossary. All contents of this document are copyright of Integrated Device Technology, Inc. All rights reserved.

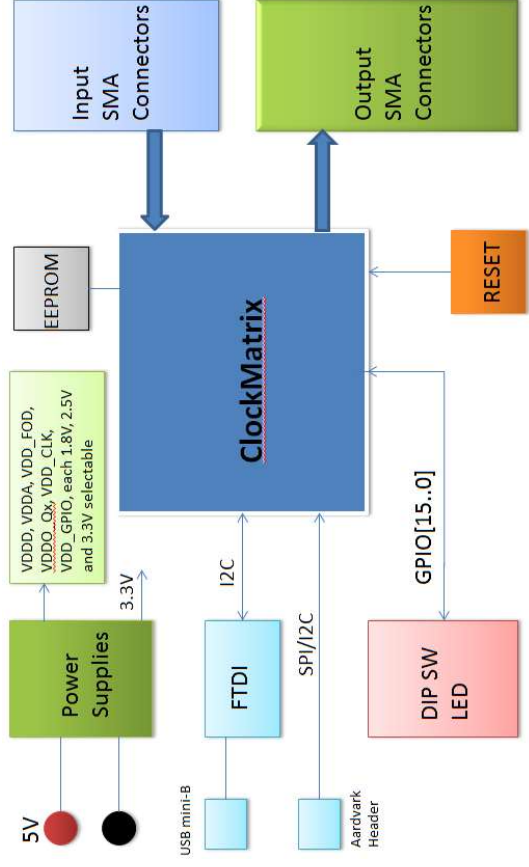

PROJECT NAME	Infra3	Fidus Systems	132 Perry Post Drive, Ottawa, ON K2K 6J8
DESIGN	DB	TITLE	f i d u s
DRAWN	DB	SUBTITLE	IDT8A34001
DB	DB	BLOCK DIAGRAM	DRAWING NUMBER
CHECK	DB	SK-10280-01	REVISION
DB	DB	27 October 2016	1.2
			SHEET
			1 OF 9

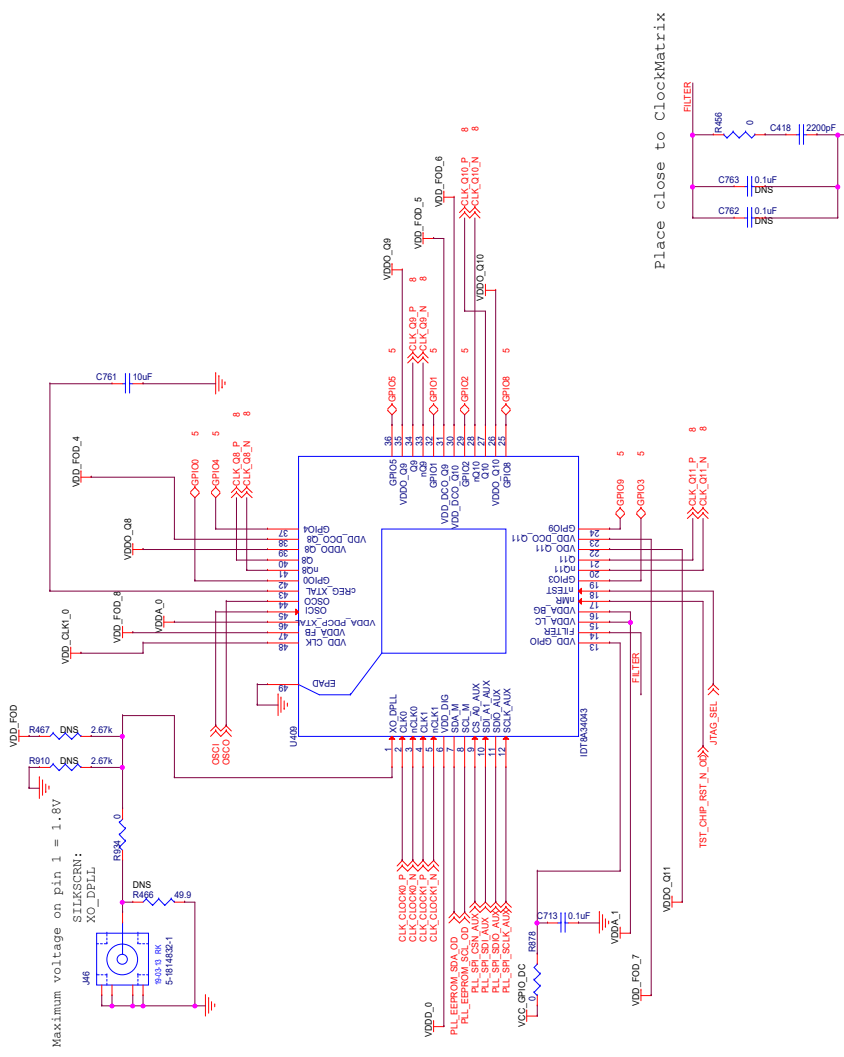

File	<File>
Size	Document Number
Ver	C
Date	Monday, May 21, 2018

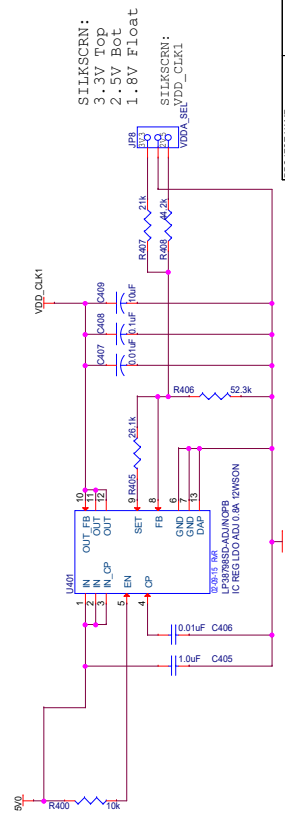
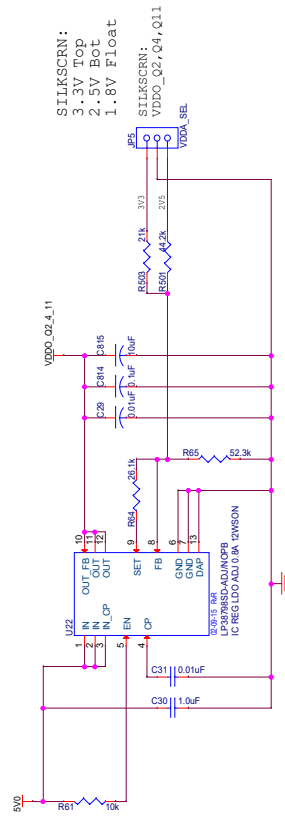
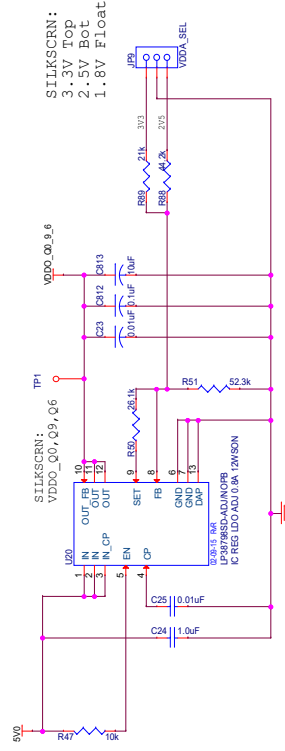
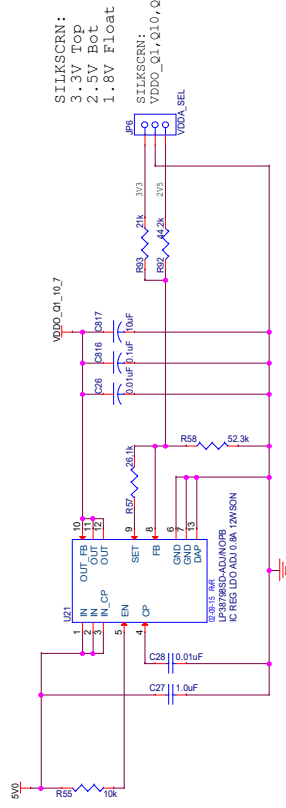
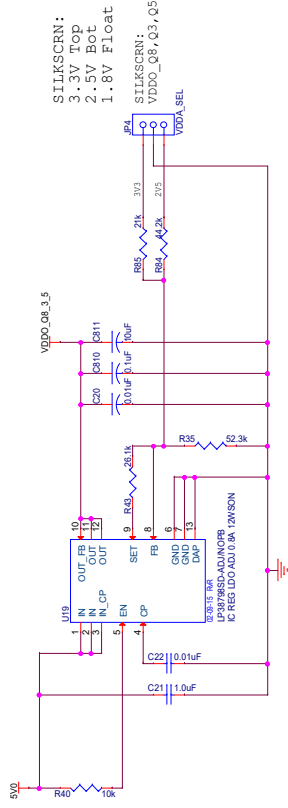

PROJECT NAME	f i d u s	Fidus Systems
DESIGN	Indire3	387 Terry Fox Drive, Ottawa, ON K2K 6J8
TITLE		
DB		
DRAWN		
SUBTITLE	IDT8A34001	Power Supplies 2
DRAWING NUMBER		
CHECK		
RELEASE DATE	27 October 2016	
REVISION	1.2	
SHEET	3	OF 9

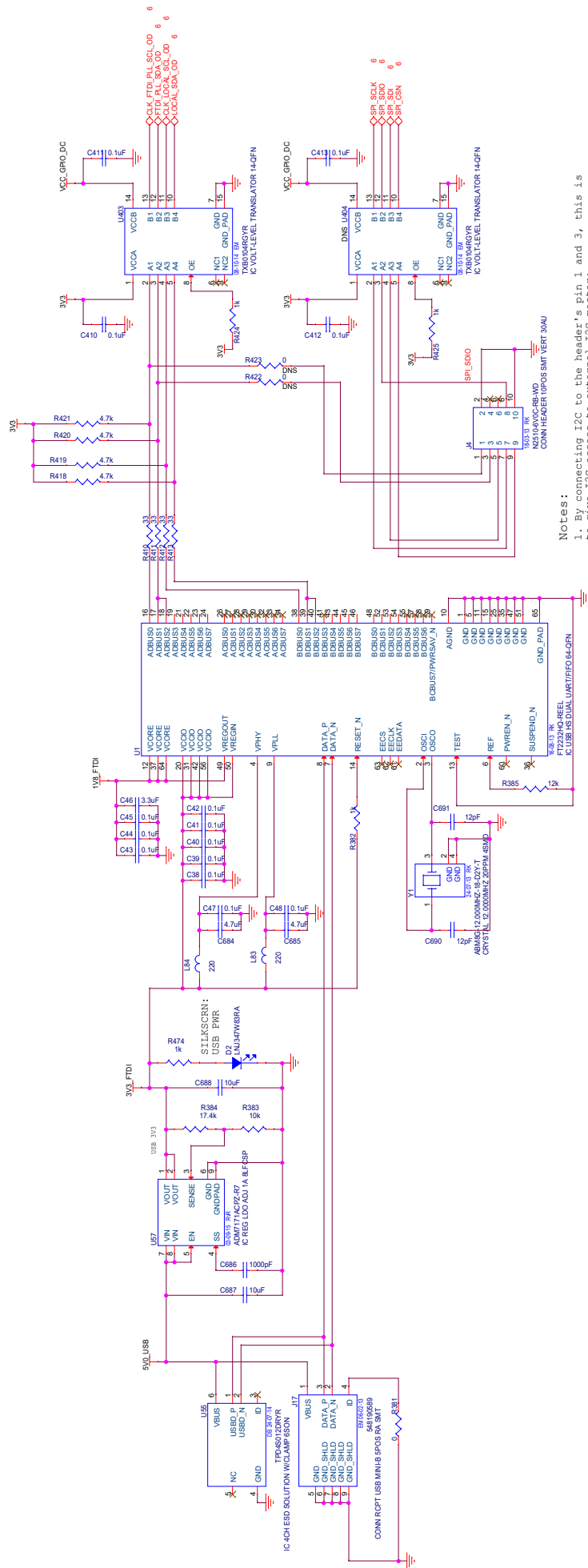

Notes:

1. By connecting I2C to the header's pin 1 and 3, this is to give I2C access to external I2C master;
2. By installing R926 and R927, FTDI can also access Aux I2C port (also removing R87 and R88). This feature is not expected to be used.
3. Normal use: FTDI controls I2C port; Header is connected to Aux Port in SFI configuration.

PROJECT NAME	fidus
DESIGN	IDT8A34001
DRAWN	FTDI USB Interface
DB	DRAWING NUMBER
DB	SK-10290-01
CHECK	REVISION
DB	1.2
RELEASE DATE	27 October 2016
SHEET	4
OF	9

PROJECT NAME: fidus
 TITLE: IDT8A34001
 SUBTITLE: FTDI USB Interface
 DRAWING NUMBER: SK-10290-01
 REVISION: 1.2
 RELEASE DATE: 27 October 2016
 SHEET: 4 OF 9

PROJECT NAME: fidus
 TITLE: IDT8A34001
 SUBTITLE: FTDI USB Interface
 DRAWING NUMBER: SK-10290-01
 REVISION: 1.2
 RELEASE DATE: 27 October 2016
 SHEET: 4 OF 9

Note for Silkscreen:
Place GPIO[x] label close to each
corresponding LED and Test point.

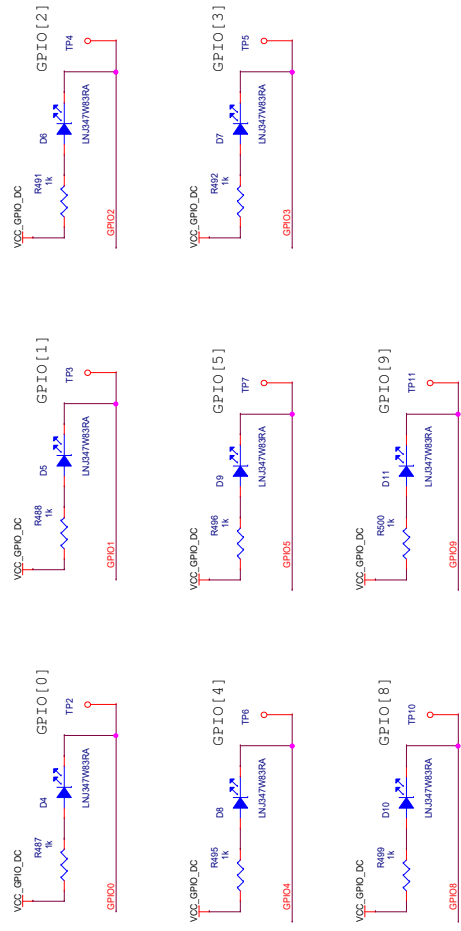

- 6 GPIO0
- 6 GPIO1
- 6 GPIO2
- 6 GPIO3
- 6 GPIO4
- 6 GPIO5

- 6 GPIO8
- 6 GPIO9

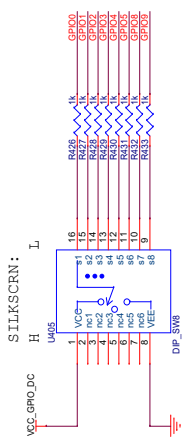

PROJECT NAME	fidus	Fidus Systems
DESIGN	Inf1ra3	382 Terry Fox Drive, Ottawa, ON K2K 6J8
RK		
DRAWN		IDT8A34001
RK		
CHECK		GPIO LEDS
DB		SK-10280-01
		RELEASE DATE
		27 October 2016
		SHEET
		5 OF
		9

Place close to
Crystal Y3

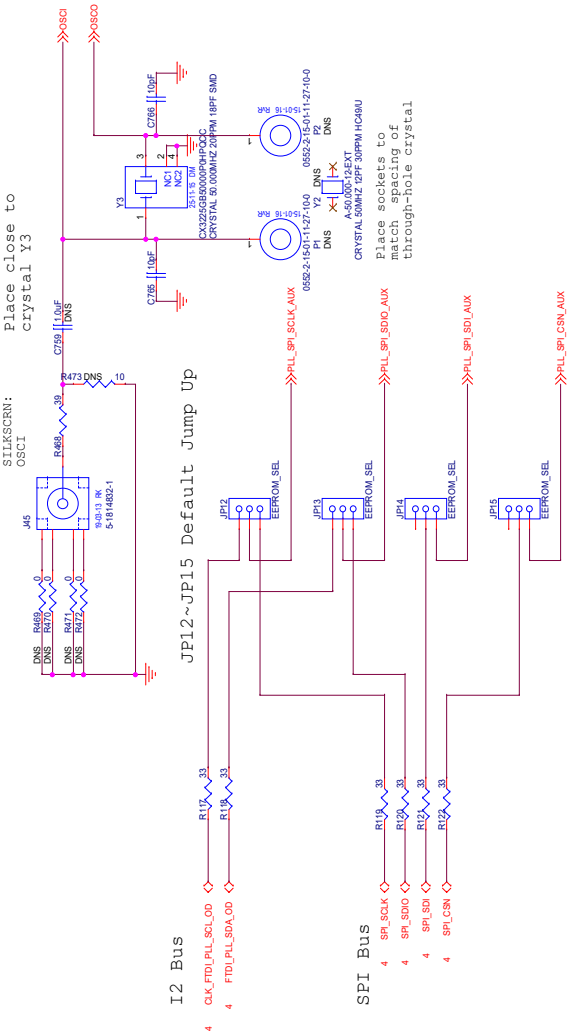

JP12~JP15 Default Jump Up

I2 Bus

- 4 CLK_FTDL_PIL_SCL_OD
- 4 FTD_PIL_SDA_OD

SPI Bus

- 4 SPI_SCLK
- 4 SPI_SDO
- 4 SPI_SDI
- 4 SPI_CSN

PLL

- 4 CLK_LOCAL_SCL_OD
- 4 LOCAL_SDA_OD

EEPROM

- 4 EEPROM_SCL_OD
- 4 EEPROM_SDA_OD

Default Jump between CM and EEPROM

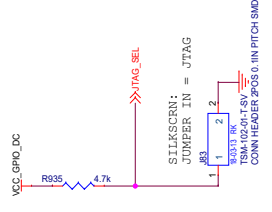

SILKSCREEN:
JUMPER IN = JTAG

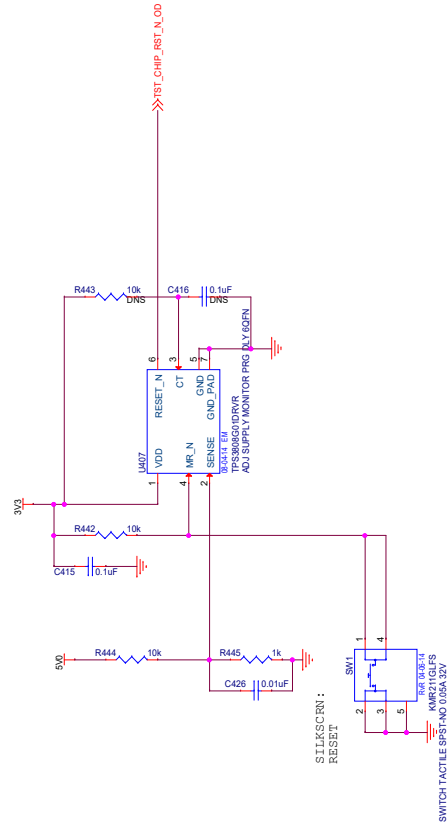

SILKSCREEN:
RESET

SWITCH TACTILE SPST AND 0.058A 3V

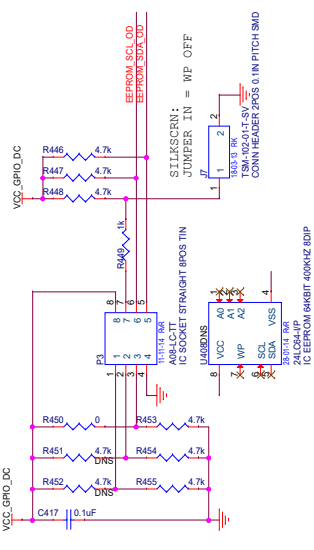

SILKSCREEN:
JUMPER IN = WP OFF

IC EEPROM 6K8BIT 400KHZ 8DIP

PROJECT NAME	Fidus Systems
DESIGN	Indire3
TITLE	Indire3
DESIGN	DB
TITLE	IDT8A34001
DRAWN	DB
SUBTITLE	PLL Core
DRAWN	DB
DRAWING NUMBER	SK-10280-01
CHECK	DB
RELEASE DATE	27 October 2016
SHEET	6 OF 9

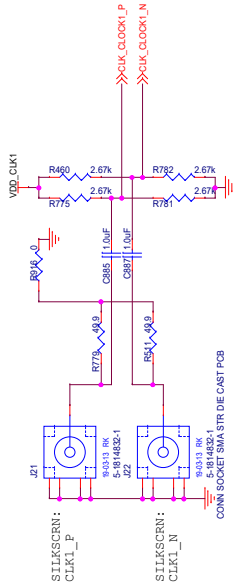
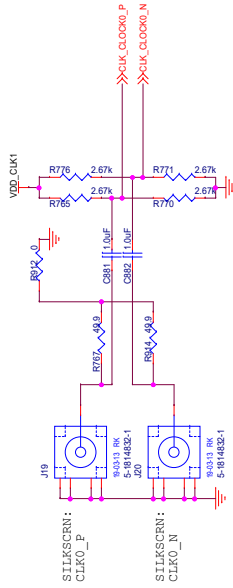
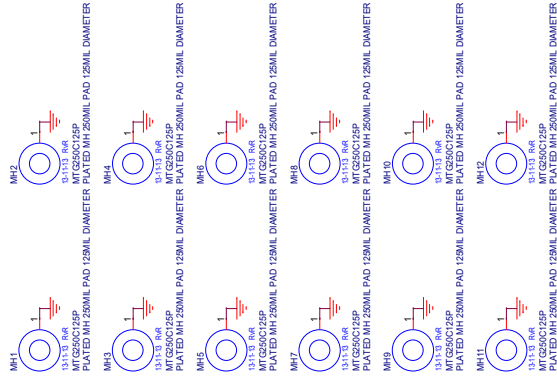
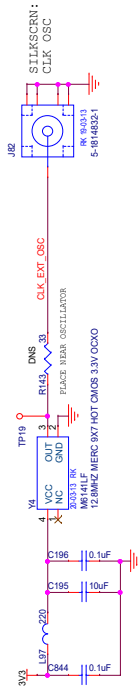

CONN SOCKET SMA STR DIE CAST PCB

PROJECT NAME		Fidus Systems	
Incl:ra3		352 Terry Fox Drive, Ottawa, ON K2K 6J8	
DESIGN	RK	TITLE	IDT8A34001
DRAWN	RK	SUBTITLE	PLL Input Clocks
PK		DRAWING NUMBER	SK-10280-01
CHECK	DB	RELEASE DATE	27 October 2016
		SHEET 7 OF 9	

PLACE PARALLEL
RESISTORS
CLOSE TO USB

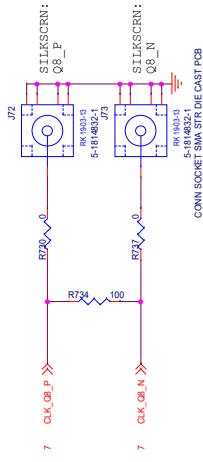

CONN SOCKET SMA STR DIE CAST PCB

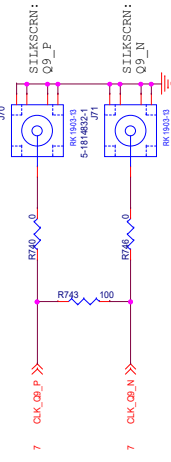

CONN SOCKET SMA STR DIE CAST PCB

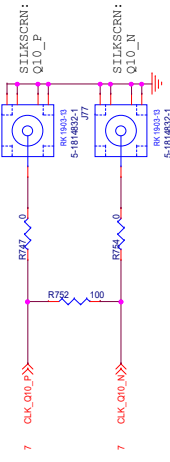

CONN SOCKET SMA STR DIE CAST PCB

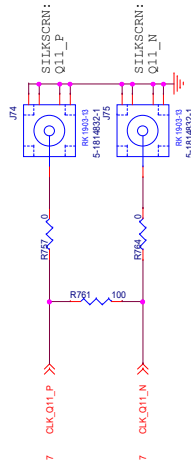

CONN SOCKET SMA STR DIE CAST PCB

PROJECT NAME	Infra3	Fidus Systems	332 Perry Post Drive, Orem, UT 84058
DESIGN	DB	TITLE	IDT8A34001
DRAWN	DB	SUBTITLE	PLL Output Clocks
CHECK	DB	DRAWING NUMBER	SK-10280-01
DB	DB	REVISION	1.2
		RELEASE DATE	27 October 2016
		SHEET	8 OF 9

