

# PC BOARD CONNECTORS

## 740 SERIES

### ■ FEATURES

- Various types of headers are available: one side shrouded, both sides shrouded, with simplified latch, and box type.
- The connector having a simplified latch prevents the connector from working loose because of vibration.
- The mini header has a clip to prevent incorrect insertion.
- A 740 series connector with a power terminal (2 in 1) for SCSI/IDE interface unit connections is also available.

### ■ SPECIFICATIONS

#### 1. Standard type

Item	Specification
Operating temperature range	-55°C to +105°C
Current rating	DC 1 A
Voltage rating	AC 250 V
Contact resistance	15 mΩ max. (DC 6 V, 0.1 A)
Insulation resistance	1000 MΩ min. (DC 500 V)
Dielectric strength	AC 500 V for 1 minute
Insertion force	3.5 kg max. (10 pins), 10.5 kg max. (30 pins)
Withdrawal force	0.25 kg min. (10 pins), 1.0 kg min. (30 pins)
Applicable wire	Flat cable: 1.27 mm (0.050 in.) pitch AWG #28 (stranded) or AWG #30 (solid)
Applicable PC board (standard)	1.6 mm

#### 2. Power connector integrated type

Item	Specification
Operating temperature range	-55°C to +105°C
Current rating	DC 1 A (signal pin) DC 5 A (power pin)
Voltage rating	AC 250 V
Contact resistance	15 mΩ max. (signal pin, DC 6 V, 0.1 A) 10 mΩ max. (power pin, DC 6 V, 0.3 A)
Insulation resistance	1000 MΩ min. (DC 500 V)
Dielectric strength	AC 500 V for 1 minute (signal pin) AC 1000 V for 1 minute (power pin)
Insertion force	50-contact signal pin: 17.5 kg max. 40-contact signal pin: 14.0 kg max. Power pin (reference value): 8.8 kg max.
Withdrawal force	50-contact signal pin: 2.0 kg max. 40-contact signal pin: 1.5 kg max. Power pin (reference value): 0.8 kg max.
Applicable PC board (standard)	1.6 mm (0.062 in.) (through hole type)

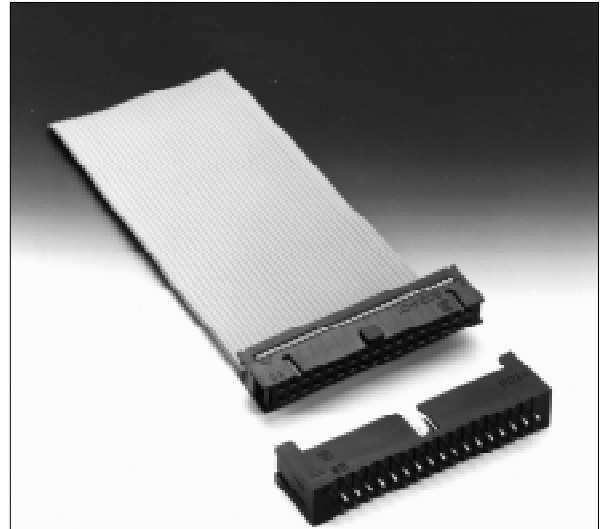

### ■ MATERIALS

#### 1. Standard type

Item	Materials	
Insulating material	Polyester (UL94V-0)	
Conductor	Copper alloy	
Plating	Contact	Gold
	Terminal	Palladium

#### 2. Power connector integrated type

Item	Materials	
Insulating material	Through hole type: Polyester (UL94V-0) SMT type: PPS (UL94V-0)	
Conductor	Copper alloy	
Plating	Signal pin contact	Gold
	Signal pin tail	Palladium
	Power pin	Solder

## ■ APPLICATION EXAMPLE

### 1. Standard type

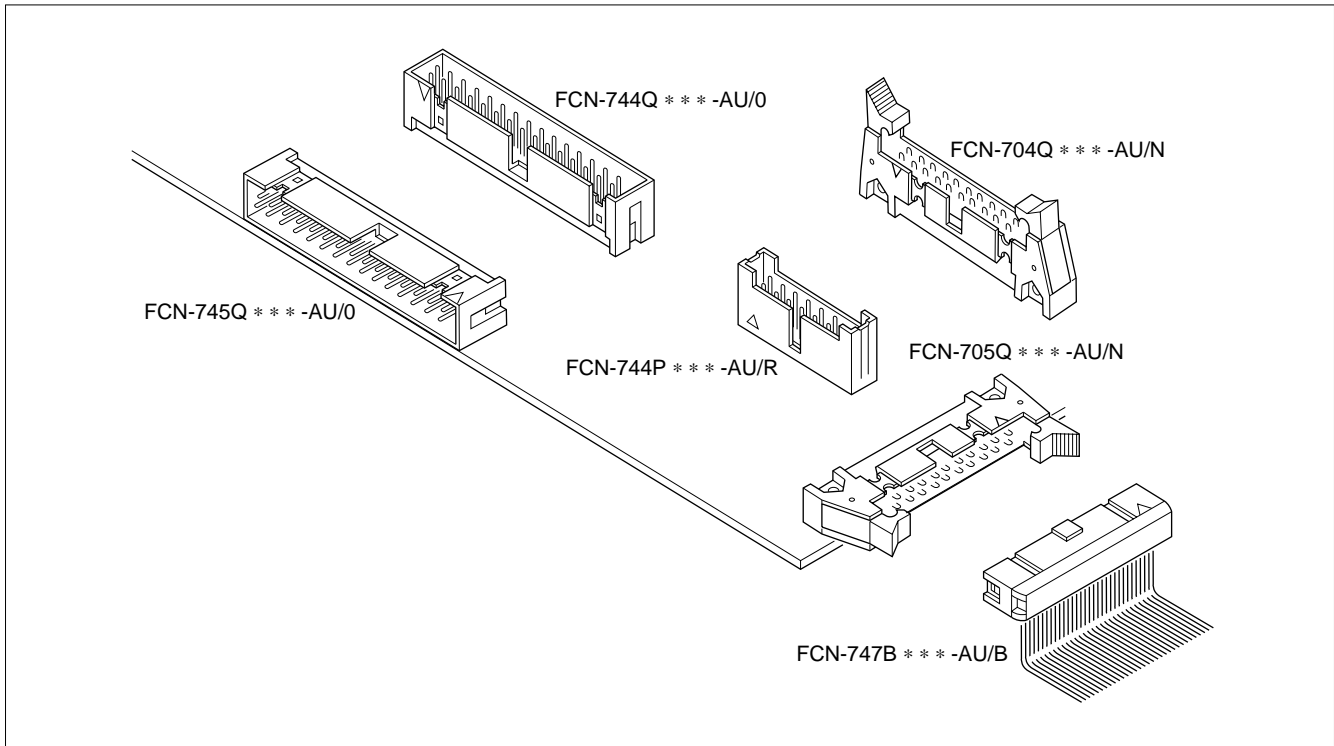

### 2. Power connector integrated type

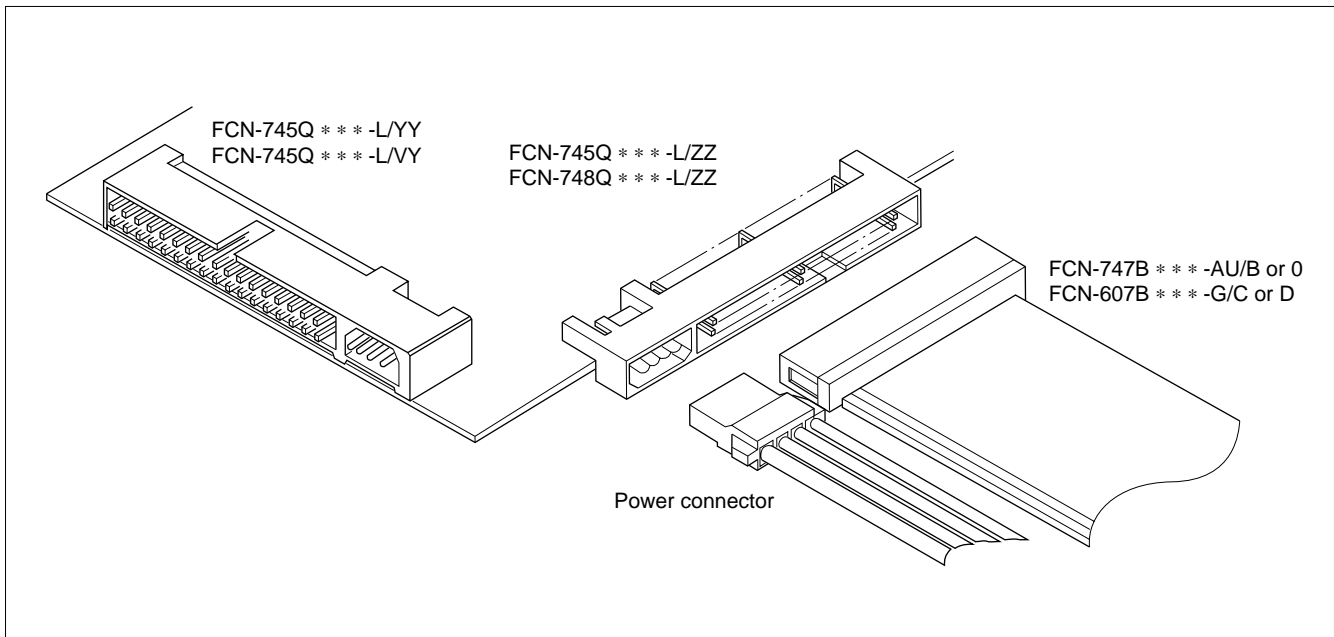

## IDC SOCKET (CLIP TYPE, CLOSED END COVER)

### ■ DIMENSIONS

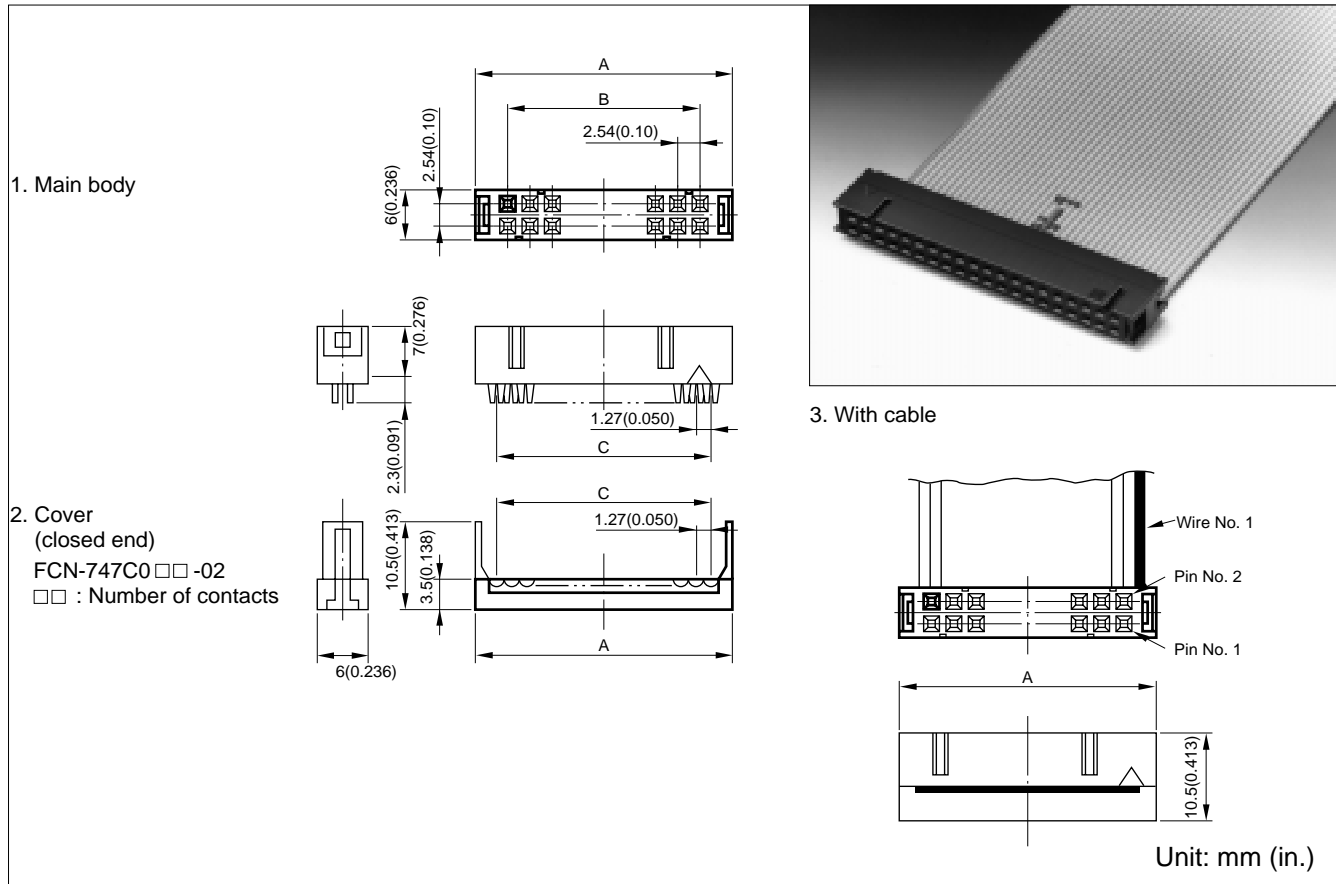

### ■ PART NUMBERS AND DIMENSIONS

Number of contacts	Part number	Dimensions: mm (in.)			Min. purchase lot quality
		A	B	C	
10	FCN-747J010-AU/B	17.27 (0.680)	10.16 (0.400)	11.43 (0.450)	30
14	FCN-747J014-AU/B	22.35 (0.880)	15.24 (0.600)	16.51 (0.650)	23
16	FCN-747J016-AU/B	24.89 (0.980)	17.78 (0.700)	19.05 (0.750)	21
20	FCN-747J020-AU/B	29.97 (1.180)	22.86 (0.900)	24.13 (0.950)	17
24	FCN-747J024-AU/B	35.05 (1.380)	27.94 (1.100)	29.21 (1.150)	15
26	FCN-747J026-AU/B	37.59 (1.480)	30.48 (1.200)	31.75 (1.250)	14
30	FCN-747J030-AU/B	42.67 (1.680)	35.56 (1.400)	36.83 (1.450)	12
34	FCN-747J034-AU/B	47.75 (1.880)	40.64 (1.600)	41.91 (1.650)	11
40	FCN-747J040-AU/B	55.37 (2.180)	48.26 (1.800)	49.54 (1.950)	9
50	FCN-747J050-AU/B	68.07 (2.680)	60.96 (2.400)	62.23 (2.450)	7
60	FCN-747J060-AU/B	80.77 (3.180)	73.66 (2.900)	74.93 (2.950)	6

## IDC SOCKET (CLIP TYPE, THROUGH END COVER)

### ■ DIMENSIONS

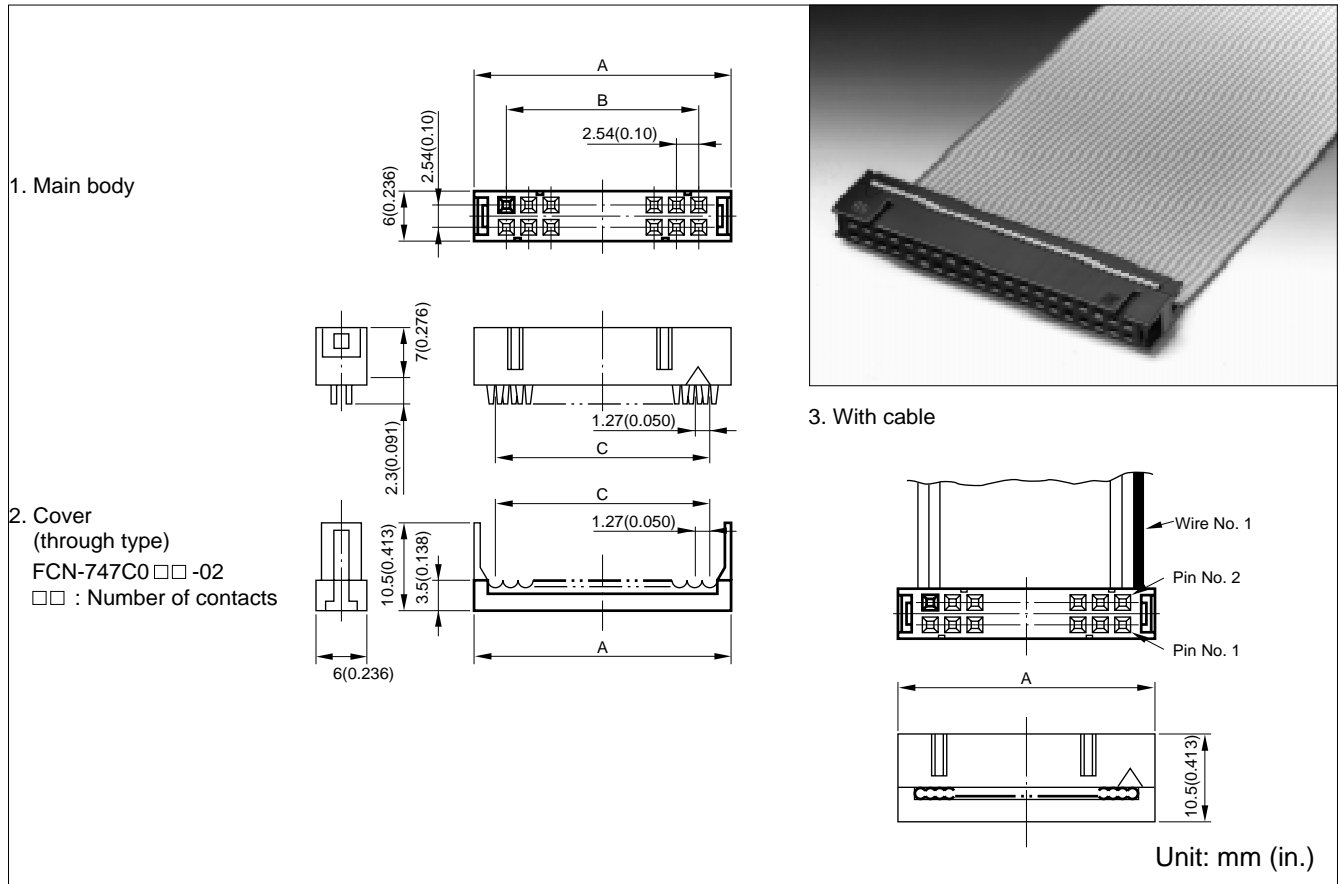

### ■ PART NUMBERS AND DIMENSIONS

Number of contacts	Part number	Dimensions: mm (in.)			Min. purchase lot quality
		A	B	C	
10	FCN-747J010-AU/0	17.27 (0.680)	10.16 (0.400)	11.43 (0.450)	30
14	FCN-747J014-AU/0	22.35 (0.880)	15.24 (0.600)	16.51 (0.650)	23
16	FCN-747J016-AU/0	24.89 (0.980)	17.78 (0.700)	19.05 (0.750)	21
20	FCN-747J020-AU/0	29.97 (1.180)	22.86 (0.900)	24.13 (0.950)	17
24	FCN-747J024-AU/0	35.05 (1.380)	27.94 (1.100)	29.21 (1.150)	15
26	FCN-747J026-AU/0	37.59 (1.480)	30.48 (1.200)	31.75 (1.250)	14
30	FCN-747J030-AU/0	42.67 (1.680)	35.56 (1.400)	36.83 (1.450)	12
34	FCN-747J034-AU/0	47.75 (1.880)	40.64 (1.600)	41.91 (1.650)	11
40	FCN-747J040-AU/0	55.37 (2.180)	48.26 (1.800)	49.54 (1.950)	9
50	FCN-747J050-AU/0	68.07 (2.680)	60.96 (2.400)	62.23 (2.450)	7
60	FCN-747J060-AU/0	80.77 (3.180)	73.66 (2.900)	74.93 (2.950)	6

## **Fujitsu Components International Headquarter Offices**

### **Japan**

Fujitsu Component Limited  
Gotanda-Chuo Building  
3-5, Higashigotanda 2-chome, Shinagawa-ku  
Tokyo 141, Japan  
Tel: (81-3) 5449-7010  
Fax: (81-3) 5449-2626  
Email: [promothq@ft.ed.fujitsu.com](mailto:promothq@ft.ed.fujitsu.com)  
Web: [www.fcl.fujitsu.com](http://www.fcl.fujitsu.com)

### **North and South America**

Fujitsu Components America, Inc.  
250 E. Caribbean Drive  
Sunnyvale, CA 94089 U.S.A.  
Tel: (1-408) 745-4900  
Fax: (1-408) 745-4970  
Email: [marcom@fcai.fujitsu.com](mailto:marcom@fcai.fujitsu.com)  
Web: [www.fcai.fujitsu.com](http://www.fcai.fujitsu.com)

### **Europe**

Fujitsu Components Europe B.V.  
Diamantlaan 25  
2132 WV Hoofddorp  
Netherlands  
Tel: (31-23) 5560910  
Fax: (31-23) 5560950  
Email: [info@fceu.fujitsu.com](mailto:info@fceu.fujitsu.com)  
Web: [www.fceu.fujitsu.com](http://www.fceu.fujitsu.com)

### **Asia Pacific**

Fujitsu Components Asia Ltd.  
102E Pasir Panjang Road  
#04-01 Citilink Warehouse Complex  
Singapore 118529  
Tel: (65) 6375-8560  
Fax: (65) 6273-3021  
Email: [fcal@fcal.fujitsu.com](mailto:fcal@fcal.fujitsu.com)  
[www.fcal.fujitsu.com](http://www.fcal.fujitsu.com)

© 2002 Fujitsu Components America, Inc. All company and product names are trademarks or registered trademarks of their respective owners. Rev. 10/2002