



AMW006-A1x Datasheet



AMW006-A1U 'Hopper-U'



AMW006-A1W 'Hopper-W'

Contents

1	Introduction	2
2	Feature Identification	3
3	Compatibility with AMW004-A01 (Hornet)	4
3.1	Serial Communications Primer	4
3.2	Hopper RTS/CTS Compatibility	4
4	Using WiConnect.....	5
5	Ordering Information.....	5
6	Schematics & Mechanical Dimensions	6
7	Revision History & Glossary	10
7.1	Revision History	10
7.2	Glossary	10

1 Introduction

The AMW006-A1x ‘Hopper’ module is a through-hole module adaptor that allows the AMW006 ‘Numbat’ Wi-Fi module to be fitted to any board conforming to the de-facto standard 2mm pitch 2x10 pin sockets commonly used in embedded applications. The module is a self-contained low-power Wi-Fi networking module with onboard microcontroller. Each Hopper is licensed to run ACKme WiConnect firmware. WiConnect provides a feature-rich and easy-to-use interface for host microprocessors requiring features including a HTTP webserver with REST API, secure TCP/UDP networking connections, file system, wireless software updates, and access to the goHACK.me IoT (Internet of Things) cloud. Features of the Hopper module adapter are detailed in Table 1 below.

The Hopper comes in two variations:

- the Hopper-U with u.FL antenna connectors
- the Hopper-W with wire antennas fitted



Figure 1. AMW006-A1U ‘Hopper-U’
Module Adapter



Figure 2. AMW006-A1W ‘Hopper-W’
Module Adapter

For details of the AMW006 ‘Numbat’ module, see the ARG-AMW006 Datasheet and the ARG-AMW006 Reference Guide.

Table 1. AMW006-A1x Features

Feature	AMW006-A1x ‘Hopper’
Product Number	AMW006-A1x
Module style	Pluggable module adapter
Serial Interfaces	4-wire UART SPI Slave I2C
Total GPIO pins	11
Indicators	3 x LEDs
Antennas	2 x wire (Hopper-W) 2 x u.FL socket (Hopper-U)
Power supply	3.3V

2 Feature Identification

Table 2. AMW006-A1x Expansion Header Connections

Pin #	Type	Hopper	AMW006
H1-1	PWR	VDD_3V3	VDD_3V3
H1-2	-	UART_TX (OUT)	GPIO_12
H1-3	-	UART_RX (IN)	GPIO_11
H1-4	GPIO	GPIO_20	GPIO_20
H1-5	-	RESET_N	RESET_N
H1-6	GPIO	WAKE	GPIO_22
H1-7	GPIO	GPIO_23	GPIO_23
H1-8	GPIO	GPIO_17	GPIO_17
H1-9	GPIO	GPIO_19	GPIO_19
H1-10	GND	GND	GND

Pin #	Type	Hopper	AMW006
H2-10	GPIO	I2C_SDA	GPIO_15
H2-9	GPIO	I2C_SCL	GPIO_14
H2-8	-	SPI_SCK (IN)	GPIO_2
H2-7	-	SPI_CS (IN)	GPIO_3
H2-6	GPIO	UART_RTS (OUT) ¹	GPIO_10
H2-5	GPIO	GPIO_21	GPIO_21
H2-4	N/C	-	-
H2-3	GPIO	SPI_MISO (OUT)	GPIO_0
H2-2	GPIO	UART_CTS (IN) ¹	GPIO_9
H2-1	-	SPI_MOSI (IN)	GPIO_5

NOTES

1. The UART_RTS and UART_CTS signals may be swapped as described in Section 3.2. The default direction is shown in the table.

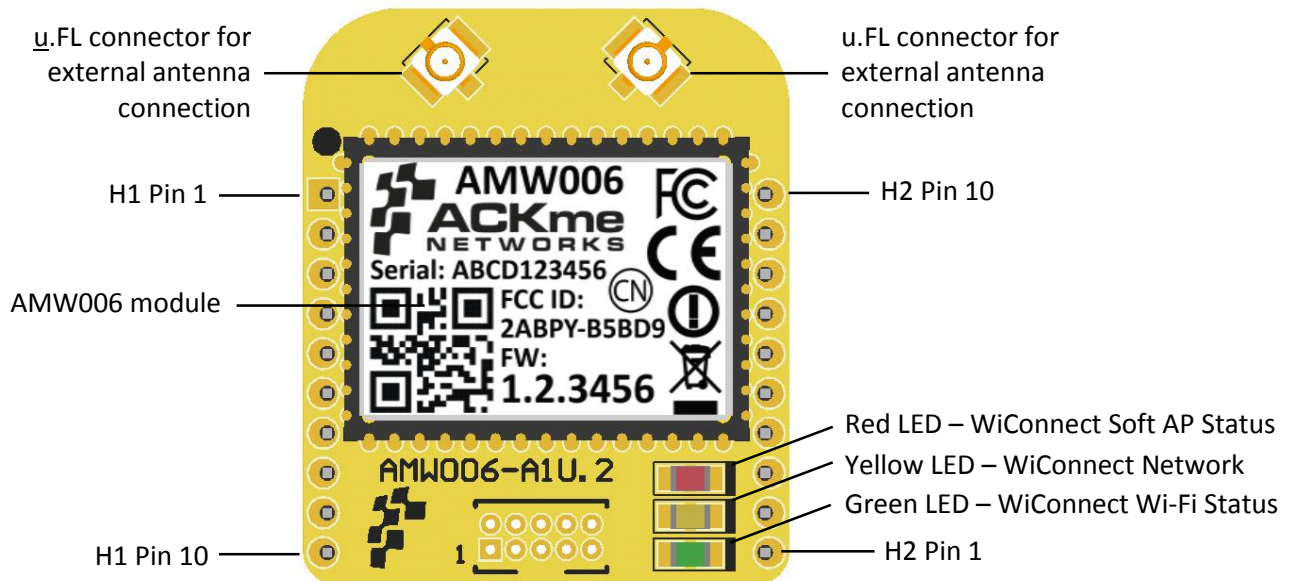

Figure 1 - AMW006-A1U Features

AMW006-A1W features are identical to AMW006-A1U features with the exception of the antenna connections.

3 Compatibility with AMW004-A01 (Hornet)

The AMW006-A1x (Hopper) module adapter is pin-for-pin compatible with the existing ACKme AMW004-A01 (Hornet) module adapter with the exception of the UART RTS/CTS connections. A full description of RTS/CTS compatibility is described in this section.

3.1 Serial Communications Primer

In traditional RS-232 serial UART communication, there are two ends of a communication link. One end is the Digital Terminating Equipment (DTE = Computer terminal) and the other end is the Digital Communications Equipment (DCE = modem).

The serial link between these two pieces of equipment can be configured to use hardware flow control signals to control data flow on the link. Hardware flow control is used by the equipment on each end of the link to signal when data is ready to be sent, and when the equipment is ready to receive more data. There are typically two hardware flow control signals known as RTS (Ready to Send) and CTS (Clear to Send).

The RTS (Ready-to-Send) signal is an output from the DCE (modem) and the CTS (Clear to Send) is an output from the DTE (computer terminal).

3.2 Hopper RTS/CTS Compatibility

The UART flow control signals on the original ACKme AMW004-A01 Hornet module adapter match the traditional RTS/CTS hardware flow control implementation described in Section 3.1 above. Since a module adapter is effectively a modem, the Hornet RTS signal is an output, and the Hornet CTS signal is an input.

Unfortunately, designers of the de-facto standard 2mm pitch 2x10 pin sockets commonly used in wireless embedded applications swapped the definition of RTS and CTS. As a result, the Hornet module adapter does not work out-of-the-box with baseboards designed for the de-facto embedded wireless standard if UART hardware flow control is enabled.

Hopper on the other hand, is configured with RTS/CTS signals that match the de-facto standard. There are two ways to enable backwards compatibility with the AMW004-A01 Hornet:

1. Swap the RTS/CTS signals on your host microcontroller, assuming the host MCU offers this feature.
2. Two zero ohm links, R13 and R14, on the underside of the Hopper PCB can be modified. After the modification, the operation of the Hopper and Hornet UART with hardware flow control is identical. A diagram showing how to make the modification is shown below.

The Hopper default configuration is shown on the Hopper board, and as horizontal orientation, black/gray in the detail diagram.

The Hornet compatible configuration is shown as red with vertical orientation, in the detail diagram.

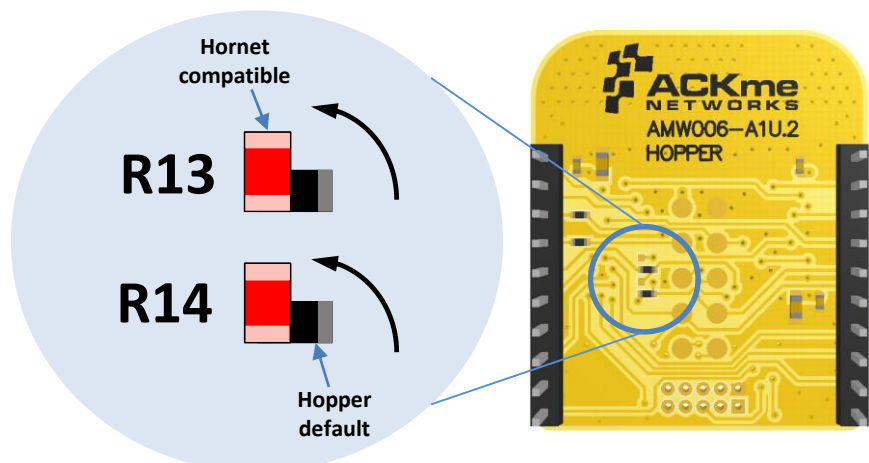

4 Using WiConnect

For a description of how to use the AMW006-A1x module adapter with WiConnect, see the ARG-AMW006E Reference Guide and the WiConnect Reference Guide, available online at <http://wiconnect.ack.me>.

A number of simple and more sophisticated example applications are also provided to help you get the most out of WiConnect and the AMW006 module.

To obtain the board version, issue the WiConnect ‘version’ command as shown below.



```
> version
WiConnect-2.1.0.15, Built:2015-02-02 20:23:14 for AMW006.4, Board:AMW006-A1W.1
```

NOTE. Early production Hopper module adapters return a slightly different board type: Board:AMW006-A01.1

5 Ordering Information

Table 4 provides ordering information for AMW006-A1x and related evaluation boards.

Table 3. Ordering Information

Part Number	Picture	Description
AMW006-A1U ‘Hopper-U’		Hopper-U module adapter. Includes AMW006 module.
AMW006-A1W ‘Hopper-W’		Hopper-W module adapter. Includes AMW006 module.
AAE001 ‘Marlin’		Bare bones evaluation board that takes an AMW006-A1x Hopper module adapter. Does NOT include an AMW006-A1x ‘Hopper’ module adapter!

6 Schematics & Mechanical Dimensions

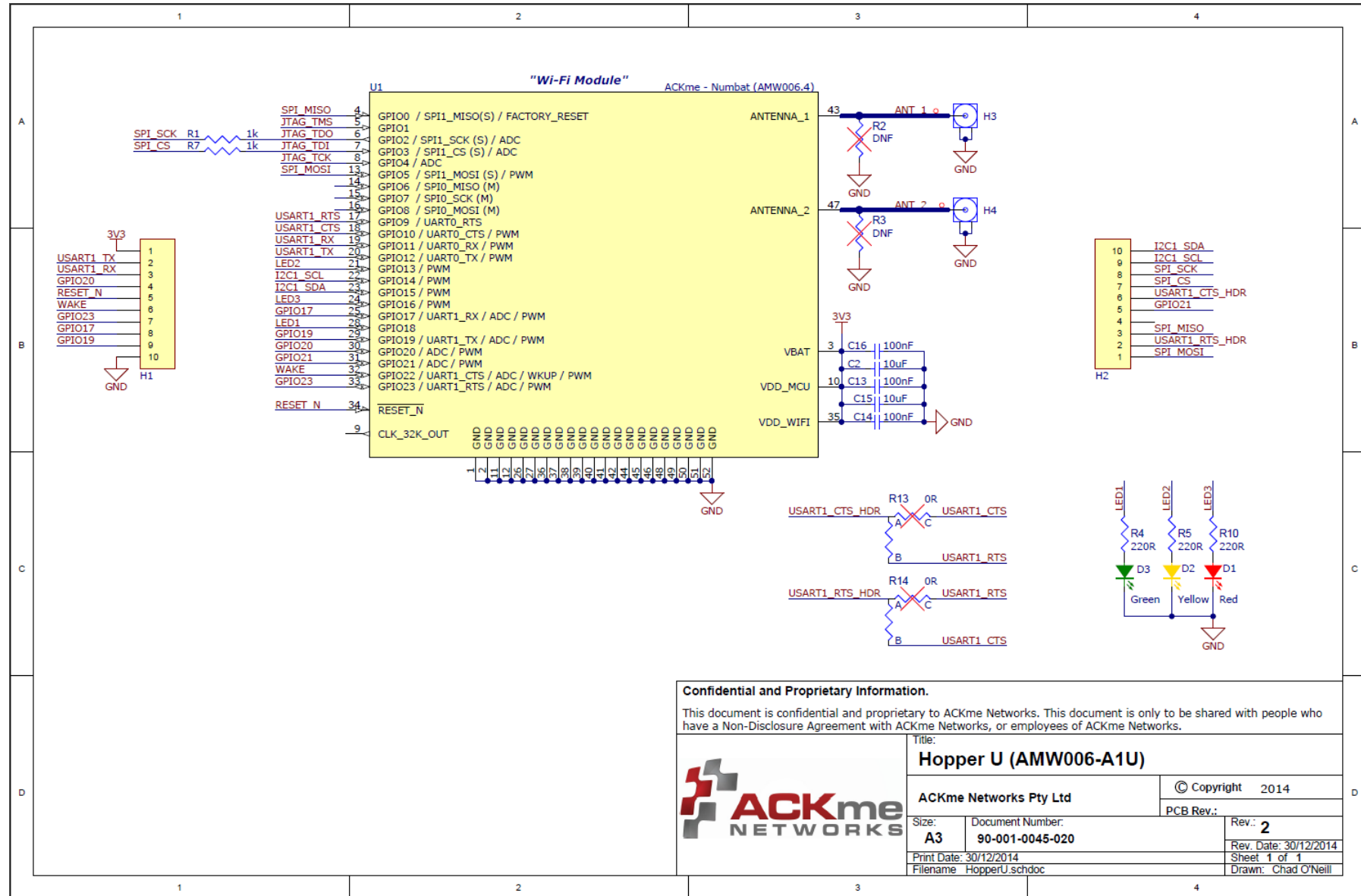

Confidential and Proprietary Information.

This document is confidential and proprietary to ACKme Networks. This document is only to be shared with people who have a Non-Disclosure Agreement with ACKme Networks, or employees of ACKme Networks.

Title: Hopper U (AMW006-A1U)		© Copyright 2014	
ACKme Networks Pty Ltd		PCB Rev.:	
Size: A3	Document Number: 90-001-0045-020	Rev.: 2	
Print Date: 30/12/2014		Rev. Date: 30/12/2014	
Filename: HopperU.schdoc		Sheet 1 of 1	
		Drawn: Chad O'Neill	

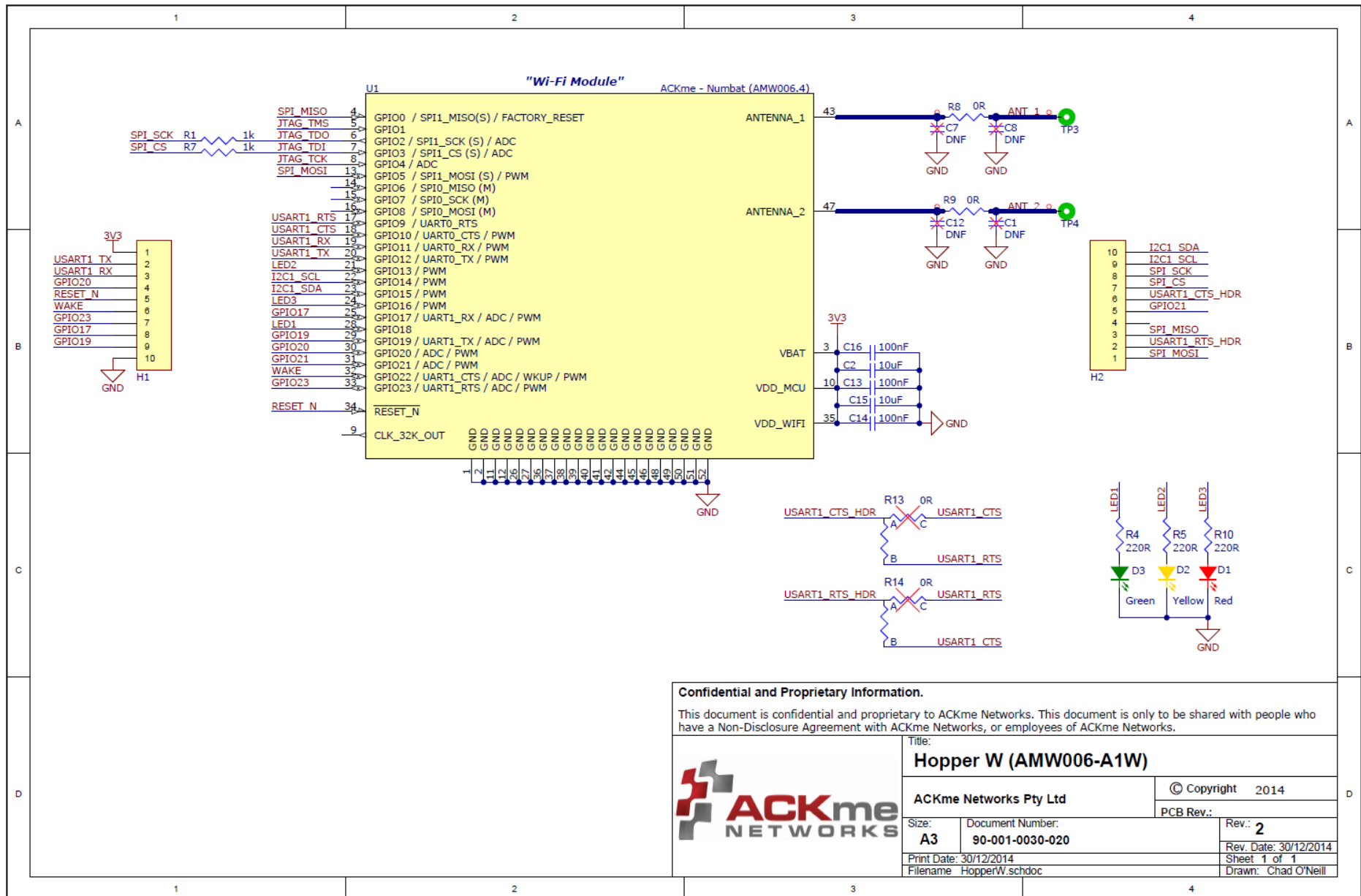

Confidential and Proprietary Information.

This document is confidential and proprietary to ACKme Networks. This document is only to be shared with people who have a Non-Disclosure Agreement with ACKme Networks, or employees of ACKme Networks.

Title: Hopper W (AMW006-A1W)	
ACKme Networks Pty Ltd	© Copyright 2014
Size: A3	Document Number: 90-001-0030-020
Print Date: 30/12/2014	Rev.: 2
Filename: HopperW.schdoc	Rev. Date: 30/12/2014
	Sheet 1 of 1
	Drawn: Chad O'Neill

Mechanical Dimensions for AMW006-A1x 'Hopper U'

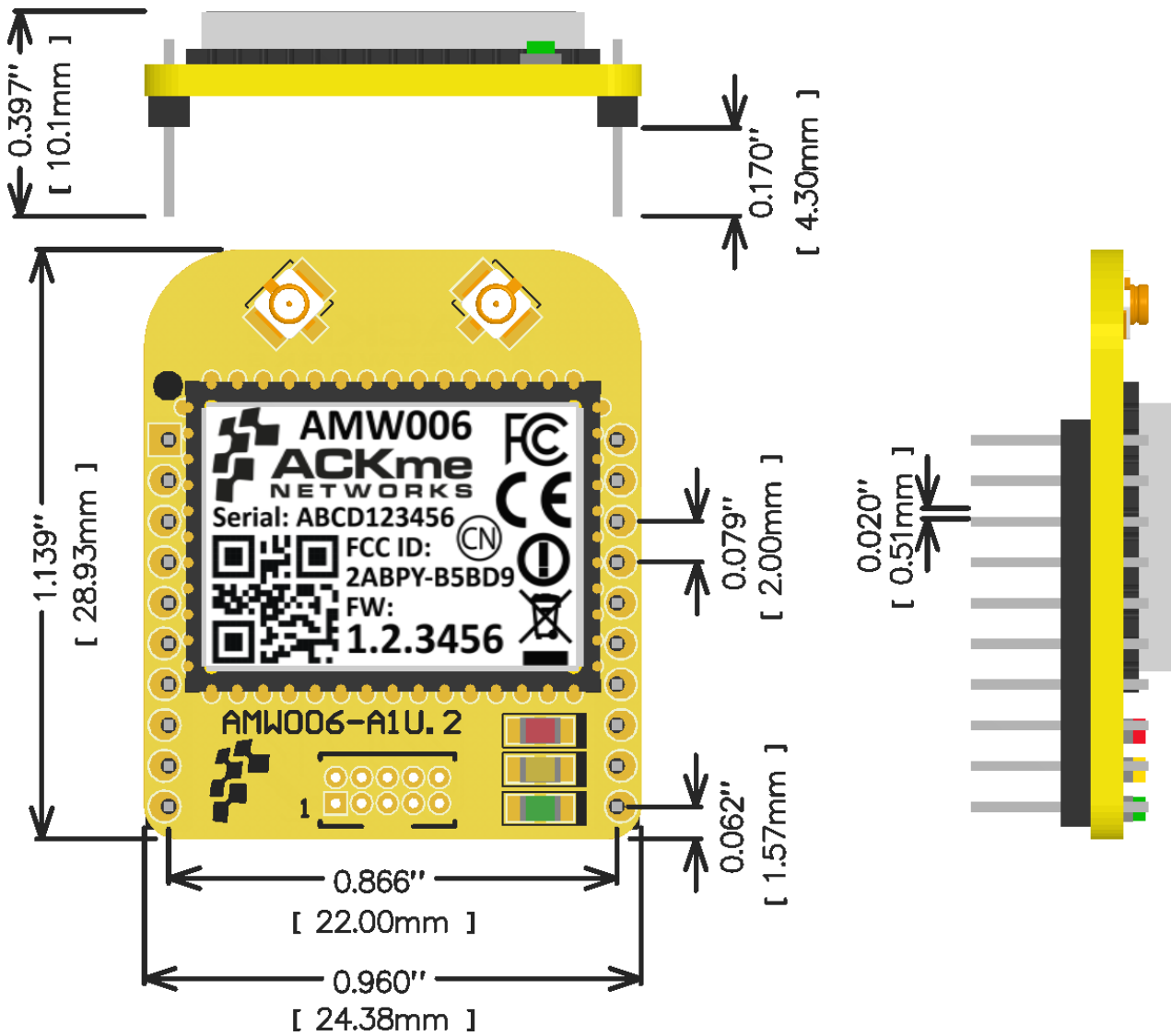

Mechanical Dimensions for AMW006-A1x 'Hopper W'

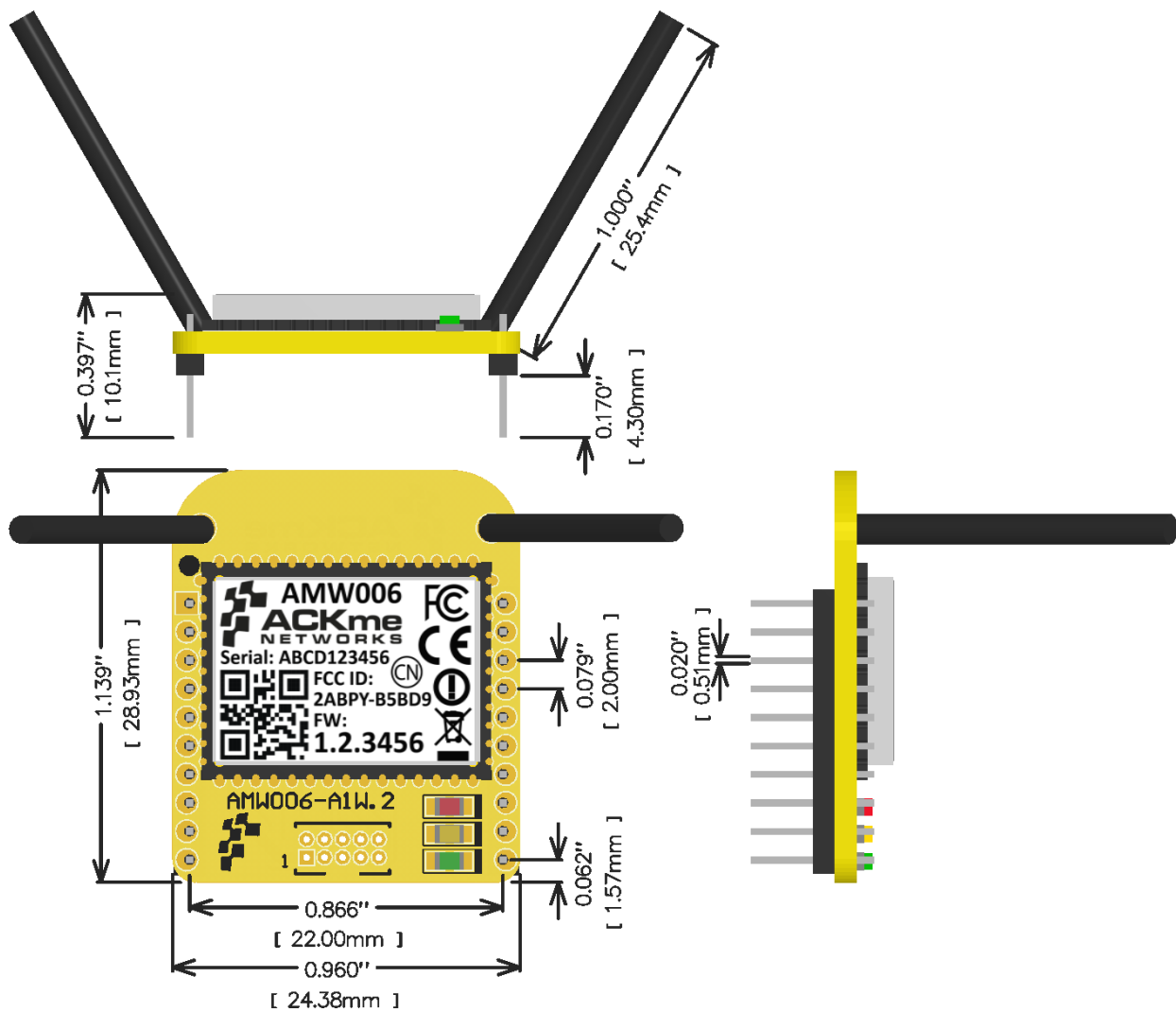

7 Revision History & Glossary

7.1 Revision History

Table 4: Document Revision History

Revision	Date	Change Description
ADS-MW006-A1x-100R	February 12, 2015	First release
ADS-MW006-A1x-101R	July 8 12, 2015	Swapped RTS/CTS pins to match the default configuration at manufacturing

7.2 Glossary

In most cases, acronyms and abbreviations are defined on first use. A comprehensive list of acronyms and other terms used in ACKme Networks documents are provided on the ACKme Networks website at <http://ack.me/FAQs/Glossary>.



Smart.
Connected.
Energy-Friendly.



Products
www.silabs.com/products



Quality
www.silabs.com/quality



Support and Community
community.silabs.com

Disclaimer

Silicon Labs intends to provide customers with the latest, accurate, and in-depth documentation of all peripherals and modules available for system and software implementers using or intending to use the Silicon Labs products. Characterization data, available modules and peripherals, memory sizes and memory addresses refer to each specific device, and "Typical" parameters provided can and do vary in different applications. Application examples described herein are for illustrative purposes only. Silicon Labs reserves the right to make changes without further notice and limitation to product information, specifications, and descriptions herein, and does not give warranties as to the accuracy or completeness of the included information. Silicon Labs shall have no liability for the consequences of use of the information supplied herein. This document does not imply or express copyright licenses granted hereunder to design or fabricate any integrated circuits. The products are not designed or authorized to be used within any Life Support System without the specific written consent of Silicon Labs. A "Life Support System" is any product or system intended to support or sustain life and/or health, which, if it fails, can be reasonably expected to result in significant personal injury or death. Silicon Labs products are not designed or authorized for military applications. Silicon Labs products shall under no circumstances be used in weapons of mass destruction including (but not limited to) nuclear, biological or chemical weapons, or missiles capable of delivering such weapons.

Trademark Information

Silicon Laboratories Inc.®, Silicon Laboratories®, Silicon Labs®, SiLabs® and the Silicon Labs logo®, Bluegiga®, Bluegiga Logo®, Clockbuilder®, CMEMS®, DSPLL®, EFM®, EFM32®, EFR, Ember®, Energy Micro, Energy Micro logo and combinations thereof, "the world's most energy friendly microcontrollers", Ember®, EZLink®, EZRadio®, EZRadioPRO®, Gecko®, ISOModem®, Micrium, Precision32®, ProSLIC®, Simplicity Studio®, SiPHY®, Telegesis, the Telegesis Logo®, USBXpress®, Zentri, Z-Wave and others are trademarks or registered trademarks of Silicon Labs. ARM, CORTEX, Cortex-M3 and THUMB are trademarks or registered trademarks of ARM Holdings. Keil is a registered trademark of ARM Limited. All other products or brand names mentioned herein are trademarks of their respective holders.



Silicon Laboratories Inc.
400 West Cesar Chavez
Austin, TX 78701
USA

<http://www.silabs.com>