

# Drop Float series - RSF10

**crydom™**

The RSF10 series drop float has been designed to eliminate problems associated with limescale build up around the pivot point of a conventional float switch. It is also suitable in more viscous liquids, that might affect the pivot action of a standard float type.

The drop float actuator allows the switch housing and float pivots to be located above the surface of the liquid and provides normally closed switch contact, opening as the liquid level rises. They are manufactured in a variety of materials, with a choice of gasket materials, to suit most commonly used liquids.

Typical applications include wall kettles and hot vending machines.

TECHNICAL SPECIFICATIONS	RSF14	RSF16
Material	Polypropylene	Polyphenylene Sulphide (PPS)
Colour	Opaque	Grey
Temp. Range °C	-20/+100	-10/ +120*
°F	-4 /+212	+14 / +248*
Min. Fluid S.G.	0.75	0.75
Must Close Level (S.G.=1)	39mm	33mm
Must Open Level (S.G.=1)	24mm	22mm

\*Maximum temperature requires ETFE cable to be specified.

ELECTRICAL SPECIFICATIONS	
Contact Form	N/C
VA Rating Max	25
Switching Voltage AC Max	240
Switching Voltage DC Max	120
Switching Current Max. A	0.6

All ratings are for resistive load only

Crydom no.	Material	Leadouts	Gaskets
RSF14Y100RF	Polypropylene	1.0m PVC 16/0.2 UL approved	Nitrile
RSF16Y100RF	PPS	1.0m PVC 16/0.2 UL approved	Nitrile
RSF16Y050TG	PPS	50cms ETFE 19/0.2	Viton

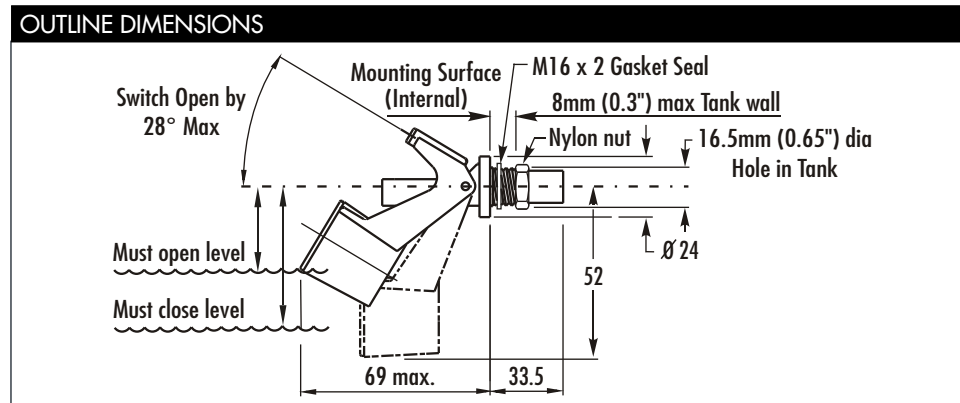

Every effort has been made to ensure that the descriptions and specifications quoted are correct, however, no liability can be accepted for any errors or omissions in this data. The detail specifications are subject to change without prior notice.

RSF10-2000UK



- *Pivot Clear of Liquid*
- *Compact design*
- *Available in Nylon, Polypropylene or PPS*
- *Many variants are UL recognised components*  
*File No. E171218*
- *WRAS approval*

Crydom Magnetics Ltd  
7 Cobham Road  
Ferndown Industrial Estate  
Wimborne  
Dorset BH21 7PE  
Tel: +44 (0) 1202 897969  
Fax: +44 (0) 1202 891918  
magnetics@crydom.com  
website: www.crydom.co.uk