

XACS413

spring return contact block - 2 NO - front mounting,
30 or 40 mm centres



Main

Range of product	Harmony XAC
Product or component type	Contact block
Component name	XACS
Electrical circuit type	Control circuit
Contact block type	Single
Type of operator	Spring return
Product compatibility	XACA ZA2B... head
Mechanical interlocking	Without mechanical interlock
Contacts type and composition	2 NO
Mounting of block	Front mounting
Contact operation	Slow-break

Complementary

Connections - terminals	Screw clamp terminals, connection capacity: 1 x 2.5 mm ² with or without cable end Screw clamp terminals, connection capacity: 2 x 1.5 mm ² with or without cable end
Horizontal fixing centres	40 mm
Vertical fixing centres	30 mm
Mechanical durability	1000000 cycles
Contact code designation	A300 AC-15, U _e = 240 V, I _e = 3 A conforming to IEC 60947-5-1 appendix A Q300 DC-13, U _e = 250 V, I _e = 0.27 A conforming to IEC 60947-5-1 appendix A
[I _{the}] conventional enclosed thermal current	10 A
[U _i] rated insulation voltage	500 V (degree of pollution: 3) conforming to IEC 60947-1
[U _{imp}] rated impulse withstand voltage	6 kV conforming to IEC 60947-1
Resistance across terminals	<= 25 MOhm
Short-circuit protection	10 A fuse protection by cartridge fuse type gG
Rated operational power in W	42 W DC-13 for 1000000 cycles, operating rate = 60 cyc/mn at 120 V, load factor = 0.5 (inductive load) conforming to IEC 60947-5-1 appendix C 45 W DC-13 for 1000000 cycles, operating rate = 60 cyc/mn at 48 V, load factor = 0.5 (inductive load) conforming to IEC 60947-5-1 appendix C 60 W DC-13 for 1000000 cycles, operating rate = 60 cyc/mn at 24 V, load factor = 0.5 (inductive load) conforming to IEC 60947-5-1 appendix C
Rated operational power in VA	140 VA AC-15 for 1000000 cycles, operating rate = 60 cyc/mn at 24 V 50/60 Hz, load factor = 0.5 (inductive load) 385 VA AC-15 for 1000000 cycles, operating rate = 60 cyc/mn at 48 V 50/60 Hz, load factor = 0.5 (inductive load) 455 VA AC-15 for 1000000 cycles, operating rate = 60 cyc/mn at 230 V 50/60 Hz, load factor = 0.5 (inductive load) 525 VA AC-15 for 1000000 cycles, operating rate = 60 cyc/mn at 127 V 50/60 Hz, load factor = 0.5 (inductive load)
Terminals description ISO n°1	(13-14)NO (23-24)NO
Terminal identifier	(11-12)NC (13-14)NO
Product weight	0.07 kg

Environment

standards	EN 60947-5-1 IEC 60947-5-1 CSA C22.2 No 14
ambient air temperature for operation	-25...70 °C
ambient air temperature for storage	-40...70 °C

The information provided in this documentation contains general descriptions and/or technical characteristics of the products contained herein. This documentation is not intended as a substitute for and is not to be used for determining suitability or reliability of these products for specific user applications. It is the duty of any such user or integrator to perform the appropriate and complete risk analysis, evaluation and testing of the products with respect to the relevant specific application or use thereof. Neither Schneider Electric Industries SAS nor any of its affiliates or subsidiaries shall be responsible or liable for misuse of the information contained herein.

vibration resistance

15 gn (f = 10...500 Hz) conforming to IEC 60068-2-6

shock resistance

100 gn conforming to IEC 60068-2-27

Contractual warranty

Warranty period

18 months

Dimensions

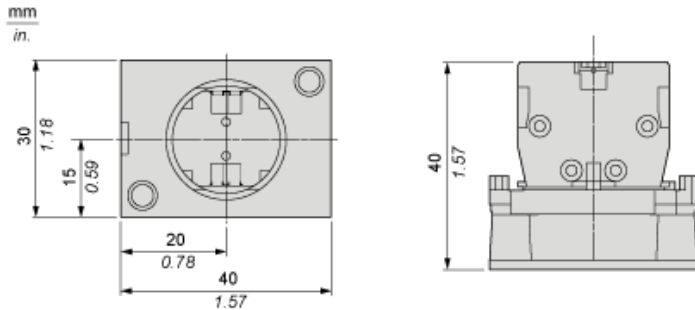

Mounting

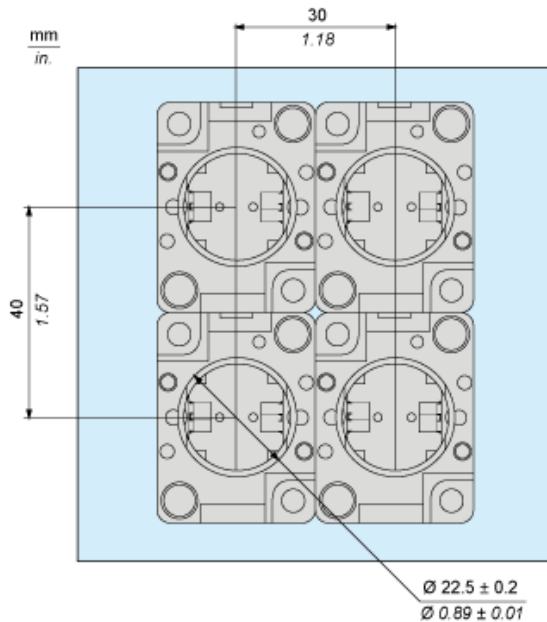

Rated Operational Power

AC Supply 50/60 Hz

Operating rate: 3600 operating cycles/hour. Load factor: 0.5.

Power broken in VA for 1 million operating cycles, AC-15 utilization category

Voltage	V	24	48	127	230
Inductive circuit	W	140	385	525	455

DC Supply

Operating rate: 3600 operating cycles/hour. Load factor: 0.5.

Power broken in W for 1 million operating cycles, DC-13 utilization category

Voltage	V	24	48	120
Inductive circuit	W	60	45	42