



## Main

Range of product	OsiSense XM
Product or component type	Electromechanical pressure sensor
Pressure sensor type	Electromechanical pressure sensor
Device short name	XMLC
Pressure sensor size	20 bar
Controlled fluid	Air (0...160 °C) Fresh water (0...160 °C) Hydraulic oil (0...160 °C)
Fluid connection type	G 1/4 (female) conforming to ISO 228
Electrical connection	Screw-clamps terminals 1 x 0.5...2 x 2.5 mm <sup>2</sup>
AWG gauge	AWG 20...AWG 14
Contacts type and composition	2 C/O
Product specific application	-
Pressure switch type of operation	Regulation between 2 thresholds
Electrical circuit type	Control circuit
Scale type	Adjustable differential
Local display	With
Adjustable range of switching point on rising pressure	1.3...20 bar
Adjustable range of switching point on falling pressure	0.6...19 bar
Possible differential maximum at high setting	11 bar
Maximum permissible accidental pressure	45 bar
Destruction pressure	90 bar
Pressure actuator	Diaphragm
Materials in contact with fluid	Brass FPM, FKM
Enclosure material	Zinc alloy
[In] rated current	3 A, B300, AC-15 (Ue = 120 V) conforming to EN/IEC 60947-5-1 1.5 A, B300, AC-15 (Ue = 240 V) conforming to EN/IEC 60947-5-1 0.1 A, R300, DC-13 (Ue = 250 V) conforming to EN/IEC 60947-5-1

Disclaimer: This documentation is not intended as a substitute for and is not to be used for determining suitability or reliability of these products for specific user applications

## Complementary

Possible differential minimum at low setting	0.7 bar (+/- 0.2 bar)
Possible differential minimum at high setting	1 bar (+/- 0.2 bar)
Maximum permissible pressure - per cycle	25 bar
Terminal block type	8 terminals
Operating rate	120 cyc/mn
Repeat accuracy	< 2 %
[Ui] rated insulation voltage	300 V conforming to CSA C22.2 No 14 500 V conforming to EN/IEC 60947-1 300 V conforming to UL 508
[Uimp] rated impulse withstand voltage	6 kV conforming to EN/IEC 60947-1
Auxiliary contacts operation	Simultaneous, snap action
Contacts material	Silver contacts
Resistance across terminals	< 25 mOhm conforming to IEC 255-7 category 3 < 25 mOhm conforming to NF C 93-050 method A
Short-circuit protection	10 A cartridge fuse type gG (gl)
Mechanical durability	5000000 cycles
Setting	External
Height	113 mm
Depth	85 mm
Width	46 mm
Product weight	0.685 kg

## Environment

Standards	CE EN/IEC 60947-5-1 UL 508 CSA C22.2 No 14
Product certifications	CSA UL EAC
Protective treatment	TC (standard version)
Ambient air temperature for operation	-25...70 °C
Ambient air temperature for storage	-40...70 °C
Operating position	Any position
Vibration resistance	4 gn (f = 30...500 Hz) conforming to IEC 60068-2-6
Shock resistance	50 gn conforming to IEC 60068-2-27
Electrical shock protection class	Class I conforming to IEC 1140 Class I conforming to IEC 536 Class I conforming to NF C 20-030
IP degree of protection	IP66 conforming to EN/IEC 60529

## Offer Sustainability

RoHS (date code: YYWW)	Compliant - since 0928 - Schneider Electric declaration of conformity <a href="#">Schneider Electric declaration of conformity</a>
REACH	Reference not containing SVHC above the threshold <a href="#">Reference not containing SVHC above the threshold</a>
Product end of life instructions	Need no specific recycling operations

## Contractual warranty

Warranty period	18 months
-----------------	-----------

Dimensions

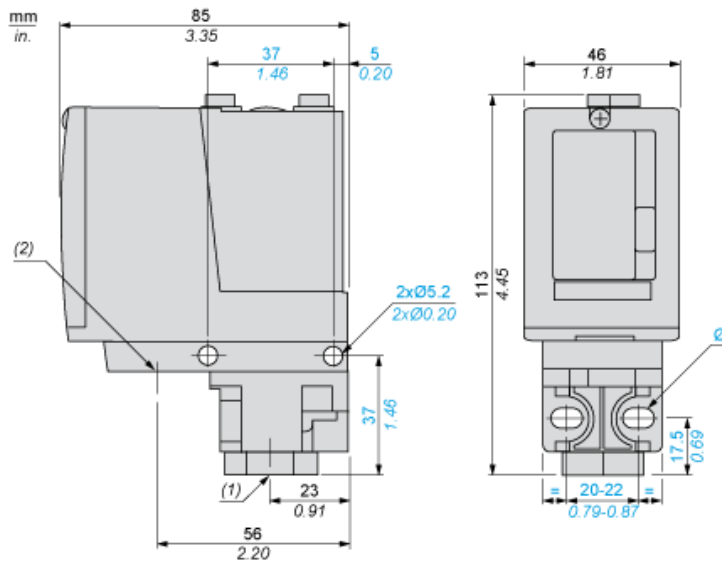

- (1) 1 fluid entry, tapped G1/4 (BSP female)
- (2) 1 electrical connections entry, tapped M20 x 1.5
- Ø : 2 elongated holes Ø 5.2 x 6.7

---

Wiring Diagram

---

Terminal Model

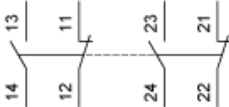

Operating Curves

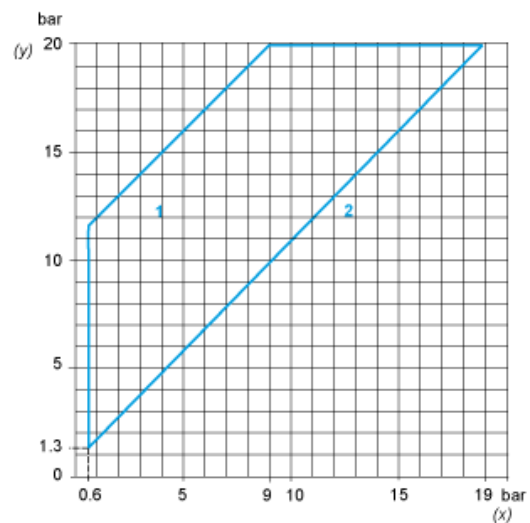

- (y) Rising pressure
- (x) Falling pressure
- 1 : Maximum differential
- 2 : Minimum differential

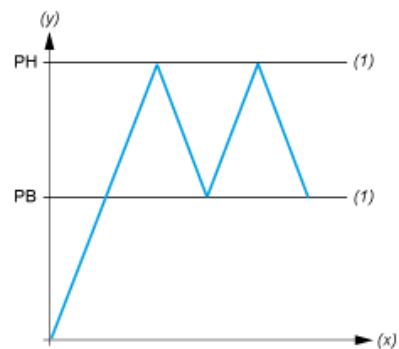

- (y) Pressure
- (x) Time
- (1) Adjustable value
- PH : High point
- PB : Below point