

TMC262-LA 30V BOB Description

Document Revision V1.10 • 2018-Apr-27

Module Top View

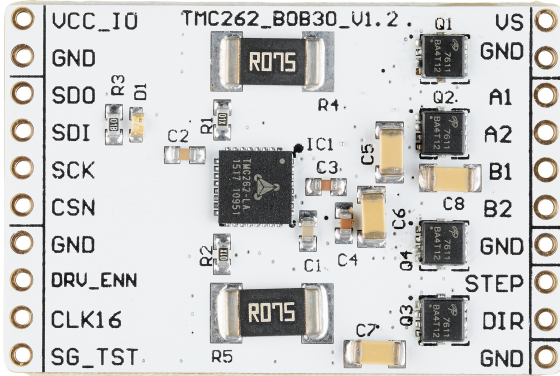

Features and additional Resources

- TMC262-LA stepper predriver & 30V power stage
- Supply voltage 9-26V (30V limit with the onboard FETs)
- $I_{phase,RMS}$ up to 2.8A
- Config via SPI, control via step/direction
- Use off-board electrolyte cap with your supply
- Board width 1.5", board height 1.0"
- 2x10 pin 0.1" header rows for pins/connectors
- Link to [additional information and IC data sheet](#)
- Link to [evaluation kit](#)

Pin List

Left	Signal	Right	Signal
1	VCC_IO (3.3V or 5V)	11	VS
2	GND	12	GND
3	SDO (data out)	13	A1
4	SDI (data in)	14	A2
5	SCK (up to 6MHz with external CLK)	15	B1
6	CSN (active low)	16	B2
7	GND	17	GND
8	DRV_ENN (active low)	18	STEP
9	CLK16 (pull to GND for internal CLK)	19	DIR
10	SG_TST (see datasheet)	20	GND

Bill of Materials

Pcs.	MPN	Value	Footprint	Description
1	MC0603B224K160CT	220nF,16V,10%	0603	Cap, Multicomp
1	MC0603X474K160CT	470nF,16V,10%	0603	Cap, Multicomp
1	MC0603B104K160CT	100nF,16V,10%	0603	Cap, Multicomp
1	GRM188R72A104KA35D	100nF,100V,10%	0603	Cap, Murata
4	CKG45NX752A106M500JH	10uF,100V,20%	CKG45NX752A106M500JH	Cap, TDK
1	LTST-C191TBKT-5A	20mA,2.8V,465nm	0603	LED,Lite-On
1	TMC262-LA	TMC262-LA	QFN32,5x5,0,5	PreDriver, TRINAMIC
2	TLR3A20WR075FTDG	0.075R,2W,1%	2512	Res, TE Connectivity
2	MCWR06X10R0FTL	10R,1%	0603	Res, Multicomp
1	MC0063W060311K	1k,1%	0603	Res, Multicomp
4	AOD603A	AOD603A	SOT114P991X239-6N	FET, Alpha&Omega

BOB Schematics

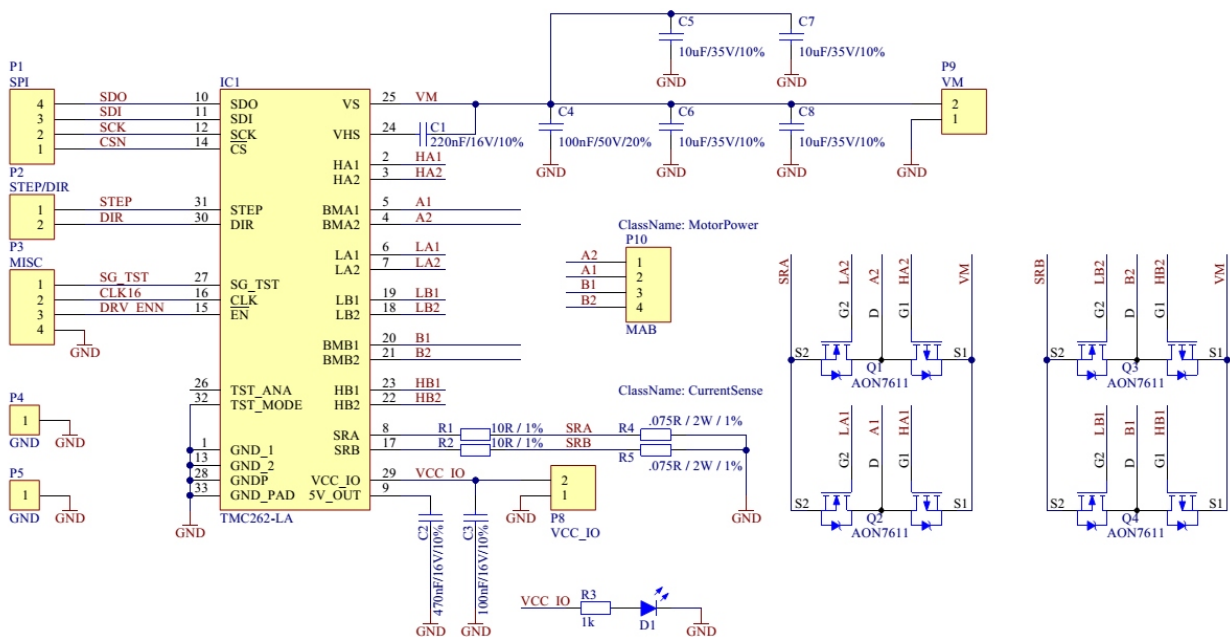

©2018 TRINAMIC Motion Control GmbH & Co. KG, Hamburg, Germany
 Download newest version at: www.trinamic.com

