

Inline terminal - IB IL 24 PWR IN/F-D-PAC - 2861894

Please be informed that the data shown in this PDF Document is generated from our Online Catalog. Please find the complete data in the user's documentation. Our General Terms of Use for Downloads are valid (<http://phoenixcontact.com/download>)



Inline power terminal block, complete with accessories (connector and labeling field), 24 V DC, with fuse (Main voltage) and diagnostics

The figure shows the version IB IL 24 PWR IN-PAC

Your advantages

- ✓ Supply of the 24 V main voltage U_M
- ✓ Main circuit protected by an internal fuse
- ✓ Feed-in or provision of the 24 V segment voltage U_S
- ✓ Diagnostic and status indicators



Key Commercial Data

Packing unit	1 pc
GTIN	 4 017918 894597
GTIN	4017918894597
Weight per Piece (excluding packing)	44.000 g
Custom tariff number	85389091
Country of origin	Germany

Technical data

Note

Utilization restriction	EMC: class A product, see manufacturer's declaration in the download area
-------------------------	---

Dimensions

Width	12.2 mm
Height	119.8 mm
Depth	71.5 mm

Interfaces

Inline terminal - IB IL 24 PWR IN/F-D-PAC - 2861894

Technical data

Interfaces

Connection method	Inline data jumper
Interface	Inline local bus

Power supply

Communications power U_L	7.5 V DC
Typical current consumption	30 mA
I/O voltage range	19.2 V DC ... 30 V DC (including all tolerances, including ripple)
Max. current consumption	4 A

General

Type of protection	Polarity protection, surge protection
--------------------	---------------------------------------

Standards and Regulations

Connection in acc. with standard	CUL
----------------------------------	-----

Environmental Product Compliance

REACH SVHC	Lead 7439-92-1
China RoHS	Environmentally friendly use period: unlimited = EFUP-e
	No hazardous substances above threshold values

Drawings

Inline terminal - IB IL 24 PWR IN/F-D-PAC - 2861894

Block diagram

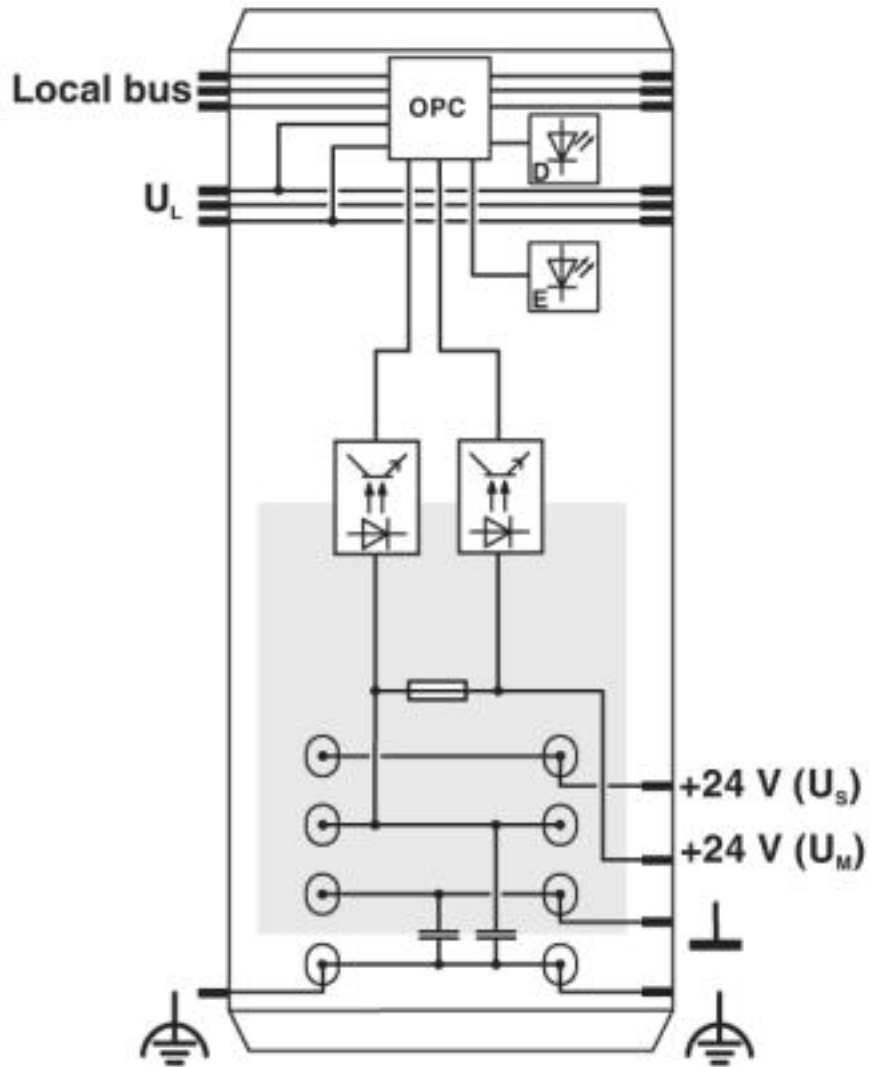

Inline terminal - IB IL 24 PWR IN/F-D-PAC - 2861894

Connection diagram

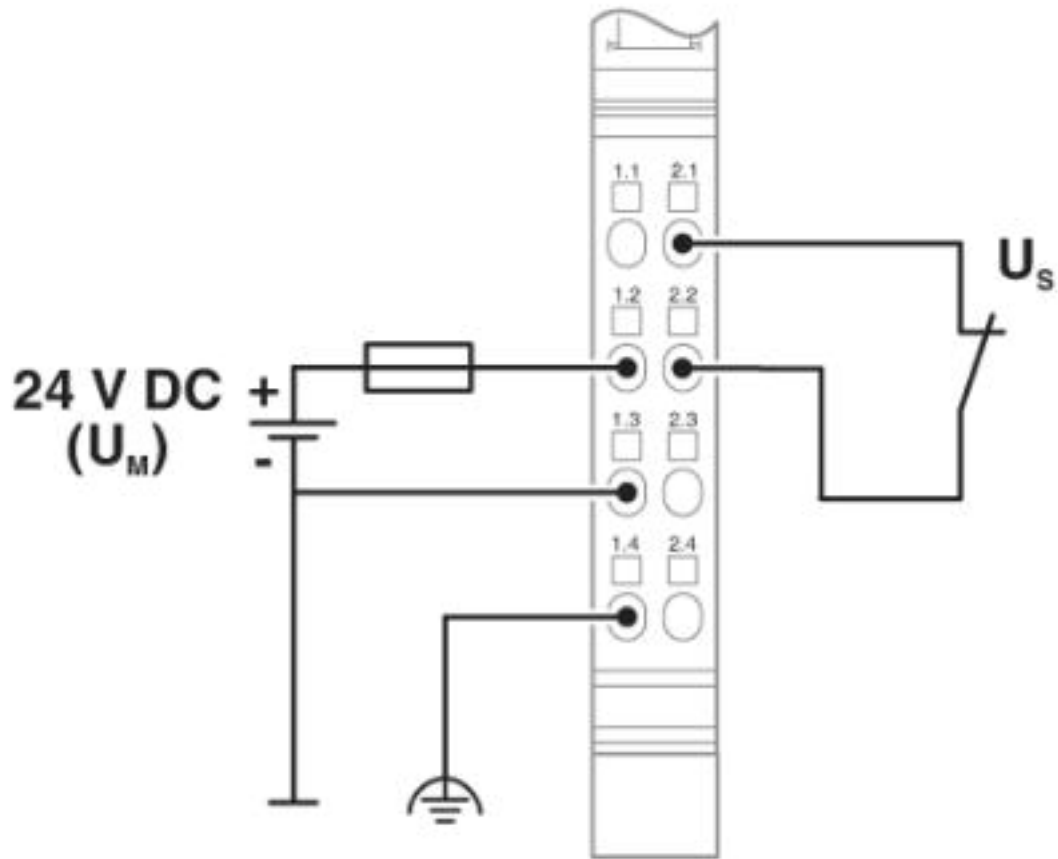

Inline terminal - IB IL 24 PWR IN/F-D-PAC - 2861894

Dimensional drawing

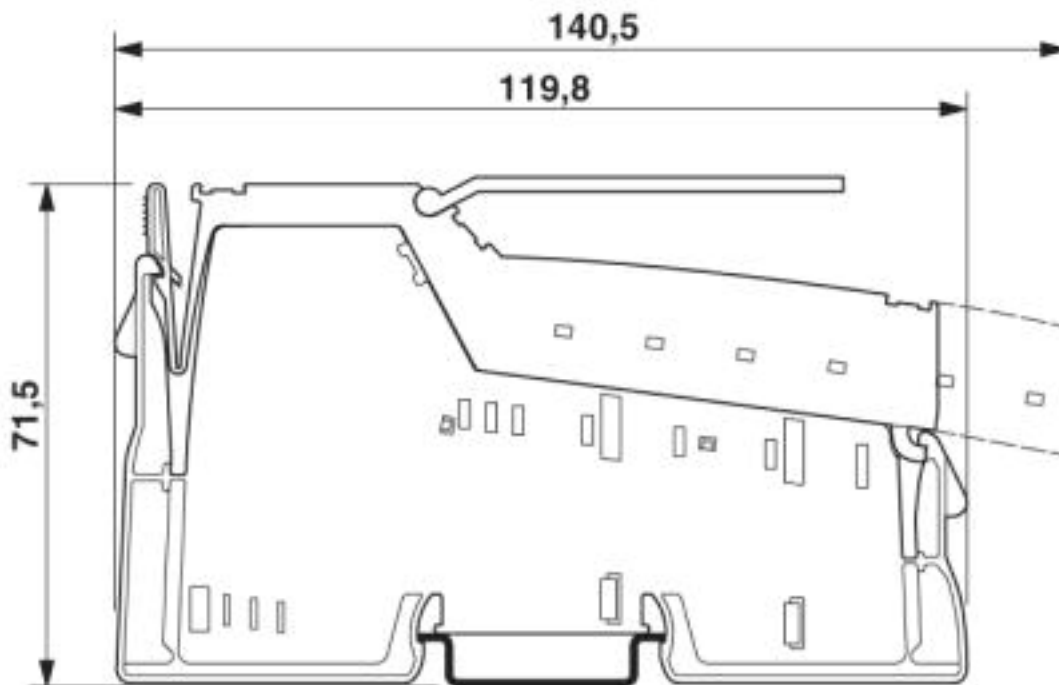

Classifications

eCl@ss

eCl@ss 4.0	27250300
eCl@ss 4.1	27250300
eCl@ss 5.0	27250300
eCl@ss 5.1	27242600
eCl@ss 6.0	27242600
eCl@ss 7.0	27242610
eCl@ss 8.0	27242610
eCl@ss 9.0	27242610

ETIM

ETIM 2.0	EC001433
ETIM 3.0	EC001600
ETIM 4.0	EC001600
ETIM 5.0	EC001600
ETIM 6.0	EC001600
ETIM 7.0	EC001600

UNSPSC

UNSPSC 6.01	43172015
UNSPSC 7.0901	43201404
UNSPSC 11	43172015

Inline terminal - IB IL 24 PWR IN/F-D-PAC - 2861894

Classifications

UNSPSC

UNSPSC 12.01	43201404
UNSPSC 13.2	32151602
UNSPSC 18.0	32151602
UNSPSC 19.0	32151602
UNSPSC 20.0	32151602
UNSPSC 21.0	32151602

Approvals

Approvals

Approvals

UL Recognized / EAC

Ex Approvals

UL Listed / cUL Listed / cULus Listed

Approval details

UL Recognized		http://database.ul.com/cgi-bin/XYV/template/LISEXT/1FRAME/index.htm	FILE E 140324
---------------	---	---	---------------

EAC		EAC-Zulassung
-----	---	---------------

Accessories

Accessories

Labeling panel

Labeling field - IB IL FIELD 2 - 2727501

Labeling field, width: 12.2 mm



Plug

Inline terminal - IB IL 24 PWR IN/F-D-PAC - 2861894

Accessories

Inline connector - IB IL SCN-PWR IN-CP - 2727637



Connector, colored, for Inline power and segment terminal blocks

Inline connector - IB IL SCN-PWR IN - 2727462



Connector, for Inline power and segment terminal blocks

Terminal marking

Insert strip - ESL 62X10 - 0809492



Insert strip, Sheet, white, unlabeled, can be labeled with: Office printing systems: Laser printer, mounting type: insert, lettering field size: 62 x 10 mm, Number of individual labels: 72