

Electronic device circuit breaker - ECP 6 - 0912033

Please be informed that the data shown in this PDF Document is generated from our Online Catalog. Please find the complete data in the user's documentation. Our General Terms of Use for Downloads are valid (<http://phoenixcontact.com/download>)



Electronic device circuit breaker, number of positions: 1, connection method: pluggable, width: 12.5 mm, fuse type: electronic, fuse type: Automatic device, mounting type: on base element, Color: black

Your advantages

- ✔ Can be plugged onto TMCP SOCKET M base
- ✔ Design width of just 12.5 mm
- ✔ Capacitive loads can be switched on and loads are only switched off in the event of an overload or short circuit
- ✔ Operating or error state indicated by LED and integrated signal contacts
- ✔ Selective protection of all 24 V DC load circuits at switched-mode power supply units
- ✔ Combination of active electronic current limitation and proven circuit breaker technology including electrical isolation
- ✔ Residual current always limited to 1.8 times the nominal current



Key Commercial Data

Packing unit	5 pc
Minimum order quantity	5 pc
GTIN	 4 046356 092050
GTIN	4046356092050
Weight per Piece (excluding packing)	69.600 g
Custom tariff number	85362010
Country of origin	Germany
Note	Made to Order (non-returnable)

Technical data

General

Installation instructions	When mounted in rows without convection cooling, the nominal device current should only be led to a maximum of 80 % due to the thermal effect during continuous operation (100 % operating factor). Parallel connection of multiple load outputs is not permitted.
Number of levels	1

Electronic device circuit breaker - ECP 6 - 0912033

Technical data

General

Mounting type	on base element
Color	black
Number of positions	1
Overvoltage category	II
Insulating material	PPS
Flammability rating according to UL 94	V0

Electrical data

Fuse	electronic
Fuse type	Automatic device
Rated surge voltage	0.5 kV
Operating voltage	24 V DC
	18 V DC ... 32 V DC
Nominal current I_N	6 A
Required backup fuse	not required, integrated failsafe element
Dielectric strength	1000 V AC (Actuation area)
	500 V AC (Installation area)
	500 V AC (Load circuit signal contact)
Degree of pollution	2
Overvoltage category	II
Insulating material group	IIIa
Switching capacity I_{CN}	Active current limitation
Closed circuit current I_0	typ. 13 mA

Dimensions

Height	60 mm
Width	12.5 mm
Depth	70 mm
Height NS 35/7,5	144 mm
Height NS 35/15	151.5 mm
Complete module height	115 mm
Complete module width	38 mm
Complete module depth	147.5 mm

Ambient conditions

Degree of protection	IP30 (Actuation area)
Ambient temperature (operation)	0 °C ... 50 °C (non-condensing)

Connection data

Connection method	pluggable
-------------------	-----------

Environmental Product Compliance

REACH SVHC	Lead 7439-92-1
------------	----------------

Electronic device circuit breaker - ECP 6 - 0912033

Technical data

Environmental Product Compliance

China RoHS	Environmentally Friendly Use Period = 50
	For details about hazardous substances go to tab "Downloads", Category "Manufacturer's declaration"

Drawings

Block diagram

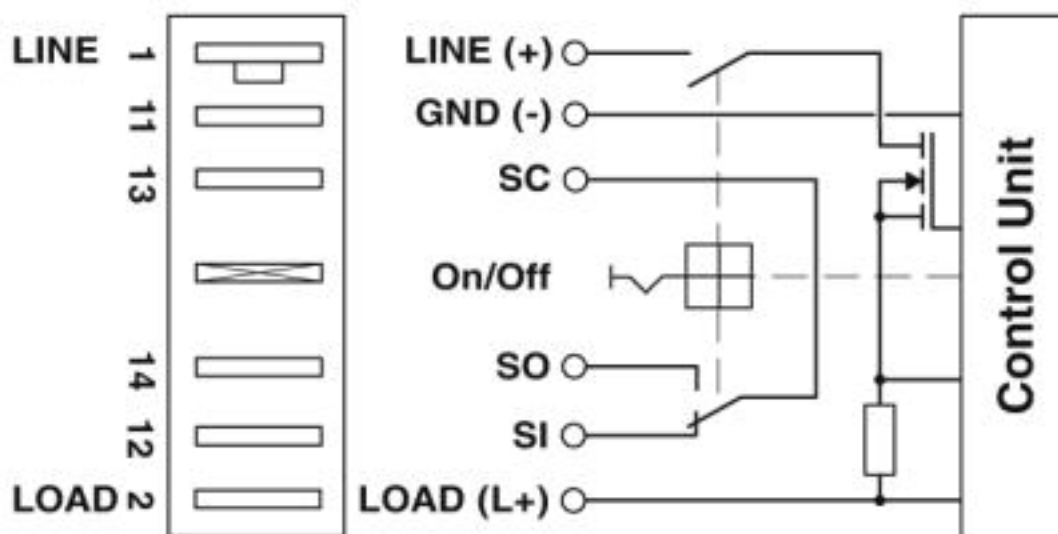

Classifications

eCl@ss

eCl@ss 4.0	27141100
eCl@ss 4.1	27141100
eCl@ss 5.0	27141100
eCl@ss 5.1	27141100
eCl@ss 6.0	27141100
eCl@ss 7.0	27141116
eCl@ss 8.0	27141116
eCl@ss 9.0	27141116

ETIM

ETIM 2.0	EC000899
ETIM 3.0	EC000899
ETIM 4.0	EC000899
ETIM 5.0	EC000899
ETIM 6.0	EC000899
ETIM 7.0	EC000899

Electronic device circuit breaker - ECP 6 - 0912033

Classifications

UNSPSC

UNSPSC 6.01	30211812
UNSPSC 7.0901	39121411
UNSPSC 11	39121411
UNSPSC 12.01	39121411
UNSPSC 13.2	39121410
UNSPSC 18.0	39121410
UNSPSC 19.0	39121410
UNSPSC 20.0	39121410
UNSPSC 21.0	39121410

Approvals

Approvals

Approvals

UL Recognized / VDE Zeichengenehmigung / EAC

Ex Approvals

Approval details

UL Recognized		http://database.ul.com/cgi-bin/XYV/template/LISEXT/1FRAME/index.htm	FILE E 140459
---------------	--	---	---------------

VDE Zeichengenehmigung		http://www2.vde.com/de/Institut/Online-Service/VDE-gepruefteProdukte/Seiten/Online-Suche.aspx	40030007
------------------------	--	---	----------

EAC			RU C-DE.A*30.B01546
-----	--	--	---------------------

Accessories

Additional products

Electronic device circuit breaker - ECP 6 - 0912033

Accessories

Box mounting base - TMCP SOCKET M - 0916589



Modular socket element, 2-position, for holding two circuit breakers, each with a single position

End cover - TMCP CONNECT LR - 0916592



End cover, width: 6 mm, Color: black

Phoenix Contact 2019 © - all rights reserved
<http://www.phoenixcontact.com>