

Electronic device circuit breaker - ECP-E3 12A - 0912052

Please be informed that the data shown in this PDF Document is generated from our Online Catalog. Please find the complete data in the user's documentation. Our General Terms of Use for Downloads are valid (<http://phoenixcontact.com/download>)



Electronic device circuit breaker, number of positions: 1, connection method: Screw connection, width: 12.5 mm, fuse type: electronic, fuse type: Automatic device, mounting type: on base element, Color: black

Your advantages

- ✓ Includes the advantages of current limitation
- ✓ Output voltage of switched-mode power supply unit remains stable
- ✓ Sufficient supply of all error-free load circuits
- ✓ Responds faster than switched-mode power supply unit to overload and short circuit
- ✓ Application - all aspects of the switched-mode power supply unit
- ✓ In addition, the ECP-E2 can be controlled remotely by the control input (12), e.g., by means of a PLC



Key Commercial Data

Packing unit	5 pc
GTIN	
GTIN	4046356144285
Weight per Piece (excluding packing)	44.540 g
Custom tariff number	85362010
Country of origin	Germany
Note	Made to Order (non-returnable)

Technical data

General

Installation instructions	When mounted in rows without convection cooling, the nominal device current should only be led to a maximum of 80% due to the thermal effect during continuous operation (100% operating factor). Special precautionary measures must be taken in systems or machines, to prevent components from restarting (e.g., use of a safety PLC). Parallel connection of multiple circuit breakers is not permitted.
Number of levels	1
Mounting type	on base element

Electronic device circuit breaker - ECP-E3 12A - 0912052

Technical data

General

Color	black
Number of positions	1
Overtoltage category	II
Insulating material	PA66/6
Flammability rating according to UL 94	V0

Electrical data

Fuse	electronic
Fuse type	Automatic device
Rated surge voltage	0.5 kV
Operating voltage	24 V DC
	24 V DC (at 50 °C (UL 2367, UL 508, ANSI/ISA 12.12.01))
	18 V DC ... 32 V DC
Nominal current I _N	12 A
Required backup fuse	not required, integrated failsafe element
Dielectric strength	max. 32 V DC (Load circuit)
Degree of pollution	2
Overtoltage category	II
Insulating material group	I
Switching capacity I _{CN}	Active current limitation
Closed-circuit current range I _O	typ. 25 mA ±5 mA (When switched on)

Dimensions

Height	60 mm
Width	12.5 mm
Depth	70 mm
Height NS 35/7,5	144 mm
Height NS 35/15	151.5 mm
Complete module height	115 mm
Complete module width	38 mm
Complete module depth	112.5 mm

Ambient conditions

Degree of protection	IP30 (Actuation area)
Ambient temperature (operation)	0 °C ... 50 °C (non-condensing)

Connection data

Connection method	Screw connection
-------------------	------------------

Standards and Regulations

Standards/specifications	UL 2367
	UL 508
	CSA 22.2 No. 14

Electronic device circuit breaker - ECP-E3 12A - 0912052

Technical data

Environmental Product Compliance

REACH SVHC	Lead 7439-92-1
China RoHS	Environmentally Friendly Use Period = 50
	For details about hazardous substances go to tab "Downloads", Category "Manufacturer's declaration"

Drawings

Block diagram

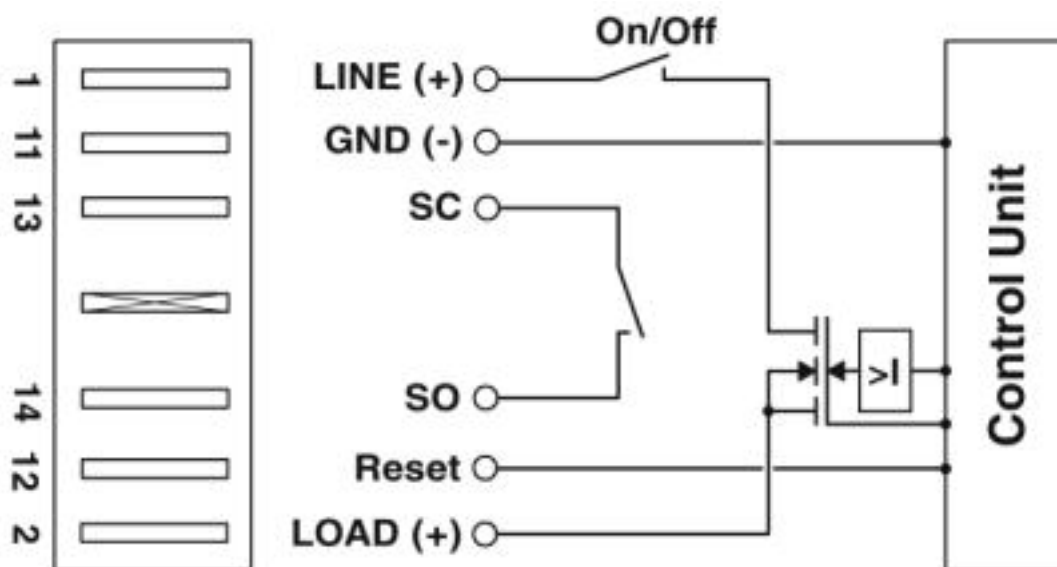

Classifications

eCl@ss

eCl@ss 4.0	27141100
eCl@ss 4.1	27141100
eCl@ss 5.0	27141100
eCl@ss 5.1	27141100
eCl@ss 6.0	27141100
eCl@ss 7.0	27141116
eCl@ss 8.0	27141116
eCl@ss 9.0	27141116

ETIM

ETIM 2.0	EC000899
ETIM 3.0	EC000899
ETIM 4.0	EC000899
ETIM 5.0	EC000899
ETIM 6.0	EC000899

Electronic device circuit breaker - ECP-E3 12A - 0912052

Classifications

ETIM

ETIM 7.0	EC000899
----------	----------

UNSPSC

UNSPSC 6.01	30211812
UNSPSC 7.0901	39121411
UNSPSC 11	39121411
UNSPSC 12.01	39121411
UNSPSC 13.2	39121410
UNSPSC 18.0	39121410
UNSPSC 19.0	39121410
UNSPSC 20.0	39121410
UNSPSC 21.0	39121410

Approvals

Approvals



Approvals

UL Recognized / EAC



Ex Approvals

UL Recognized / CSA



Approval details

UL Recognized		http://database.ul.com/cgi-bin/XYV/template/LISEXT/1FRAME/index.htm	FILE E 317172
---------------	--	---	---------------

EAC		RU C- DE.A*30.B01546
-----	--	-------------------------

