

1 Watt

- Single unregulated output
- $\pm 10\%$ input range
- SMD DIP8 package
- 1.5kVDC isolation, 3kVDC option
- Industry standard pinout
- EN\UL 62368-1 safety approvals
- Continuous short circuit protection
- Tape & reel package available
- Operating temperature -40°C to $+105^{\circ}\text{C}$
- Full load to 100°C
- 3 year warranty

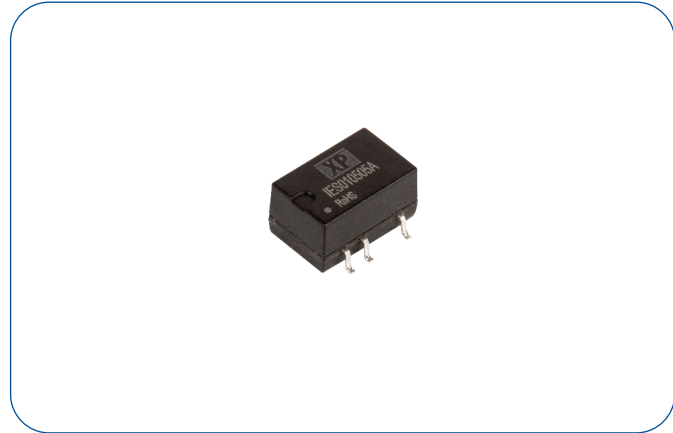

Dimensions:

IES01:
0.52 x 0.335 x 0.285" (13.2 x 8.5 x 7.25 mm)

The single output IES01 series is an ideal solution for isolating voltage rails in a distributed power supply architecture such as analog, digital, data and relay circuits. This product family offers a compact design with high efficiency, 1.5kV isolation with 3.0kV optional, short circuit protection and high operating temperature.

Models & Ratings

Input Voltage	Output Voltage	Output Current		Input Current ⁽¹⁾		Maximum Capacitive Load	Efficiency ⁽²⁾	Model Number ^(3,5)
		Minimum	Maximum	No Load	Full Load			
5V (4.5-5.5 V)	3.3V	30mA	303mA	5mA	270mA	2400 μF	74%	IES0105S03
	5V	20mA	200mA	5mA	270mA	2400 μF	82%	IES0105S05
	9V	12mA	111mA	12mA	241mA	1000 μF	83%	IES0105S09
	12V	9mA	84mA	12mA	241mA	560 μF	83%	IES0105S12
	15V	7mA	67mA	18mA	241mA	560 μF	83%	IES0105S15
	24V	4mA	42mA	18mA	241mA	220 μF	85%	IES0105S24

Notes

1. Typical input currents measured at nominal input voltage.
2. Typical value at full load.
3. Optional 3kVDC isolation add suffix '-H'
4. Standard tube quantity = 38
5. For tape & reel option add suffix '-TR'. Reel quantity = 500

Mechanical Details

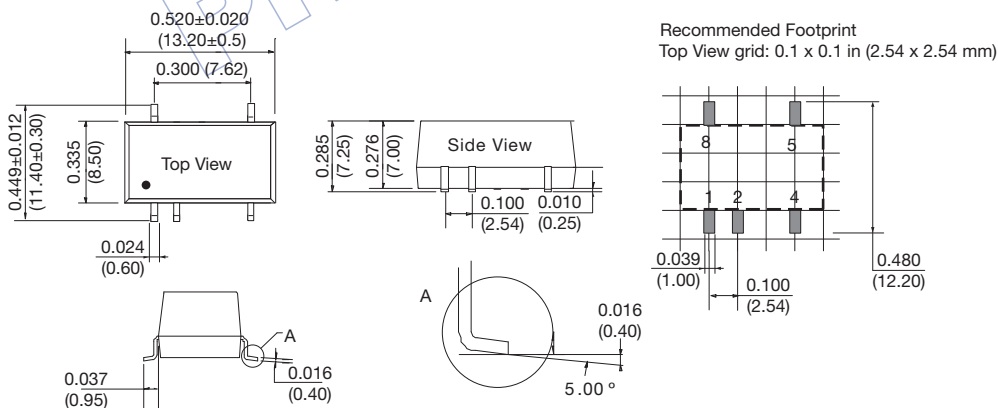

PIN CONNECTIONS	
Pin	Function
1	-Vin
2	+Vin
4	-Vout
5	+Vout
8	No Connection

Notes

1. All dimensions are in inches (mm)
2. Weight: 0.003lbs (1.4g) typical.
3. Pin pitch and length tolerance: ± 0.004 (± 0.10)
4. Case tolerance: ± 0.02 (± 0.5)

Input

Characteristic	Minimum	Typical	Maximum	Units	Notes & Conditions
Input Voltage Range	4.50		5.50	VDC	5 V nominal
Input Current					See Models and Ratings table
Input Reflected Ripple		15		mA pk-pk	Through 12 μ H inductor and 47 μ F capacitor
Input Surge			9	VDC for 1 s	5 V models
Input Filter	Capacitor				

Output

Characteristic	Minimum	Typical	Maximum	Units	Notes & Conditions
Output Voltage	3.3		24	VDC	See Models and Ratings table
Initial Set Accuracy				%	See Load Regulation Curves
Minimum Load	10			%	
Line Regulation			± 1.2	%	Per 1% change of input voltage ($\pm 1.5\%$ for 3V3 output)
Load Regulation		15/8	20/10	%	10% to 100% load, 3V3/Others
Ripple and Noise		30/50	75/100	mV pk-pk	For models ≤ 15 V/24 V models, 20 MHz bandwidth, measured using 0.1 μ F capacitor
Short Circuit Protection					Continuous, with auto recovery
Maximum Capacitive Load				μ F	See Models and Ratings table
Temperature Coefficient			± 0.02	%/°C	

General

Characteristic	Minimum	Typical	Maximum	Units	Notes & Conditions
Efficiency					See Models and Ratings table
Isolation: Input to Output	1500/3000			VDC	IES/IES-H
Switching Frequency	270		278	kHz	Full load, nominal input
Isolation Resistance	10^9			Ω	Input to output, tested at 500 VDC
Isolation Capacitance		20		pF	Input to output
Power Density			20.8	W/in ³	
Mean Time Between Failure	3500			kHrs	MIL-HDBK-217F, +25 °C GB
Weight		0.003 (1.4)		lb (g)	
Moisture Sensitivity Level (MSL)	Level 1				
Case Material	Black plastic, flame retardant UL94 V-0				
Recommended Solder Profile	IPC/JEDEC J-STD-020D.1				Peak temp ≤ 245 °C, max duration, ≤ 60 s at 217 °C

Environmental

Characteristic	Minimum	Typical	Maximum	Units	Notes & Conditions
Operating Temperature	-40		+105	°C	Derate from 100% load at +100 °C to 80% load at 105 °C
Storage Temperature	-55		+125	°C	
Case Temperature			+105	°C	
Case Temperature Rise		25/15		°C	Ambient 25°C, 3V3 output/others
Operating Humidity			95	% RH	Non-condensing
Cooling					Natural convection

Safety Approvals

Safety Agency	Safety Standard	Notes & Conditions
UL/CE	UL62368	
TUV	IEC/EN62368	

EMC: Emissions

Phenomenon	Standard	Test Level	Notes & Conditions
Conducted	EN55032	Class B	See Application Note for Class B filter
Radiated	EN55032	Class B	See Application Note for Class B filter

EMC: Immunity

Phenomenon	Standard	Test Level	Criteria	Notes & Conditions
ESD Immunity	EN61000-4-2	Air $\pm 8kV$, Contact $\pm 4kV$	B	

Load Regulation

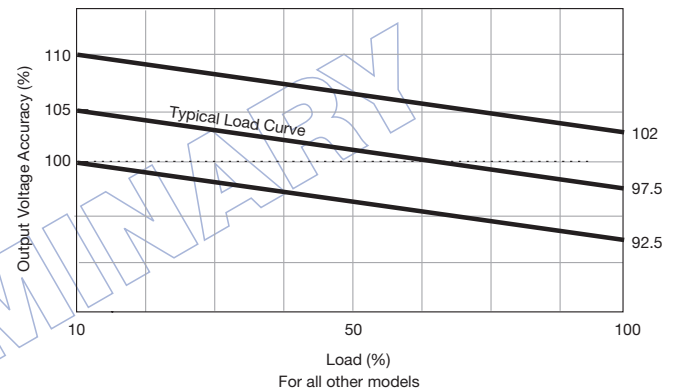
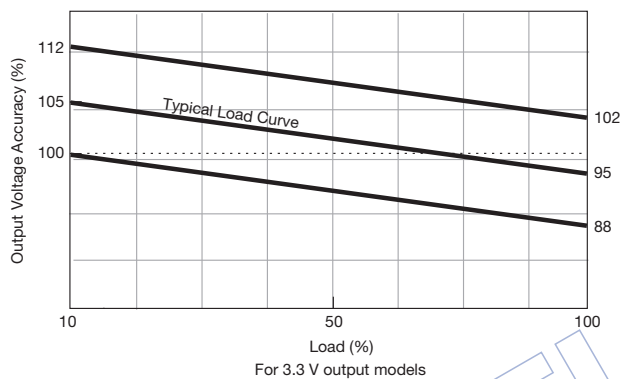

Application Note

EMI Filter for Class B Emissions

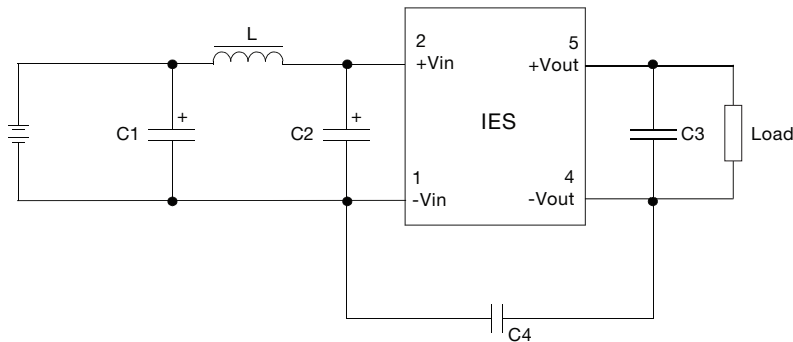

Component	Output Voltage						Notes
	3.3V	5V	9V	12V	15V	24V	
C1, C2	4.7 μ F	4.7 μ F	4.7 μ F	4.7 μ F	4.7 μ F	4.7 μ F	25V rated
C3	10 μ F	10 μ F	4.7 μ F	2.2 μ F	1 μ F	0.47 μ F	25V rated
C4				1nF	1nF	1nF	2kV rated, ML Ceramic
L	6.8 μ F	6.8 μ F	6.8 μ H	6.8 μ H	6.8 μ H	6.8 μ H	

Application Note

Temperature Derating Curve

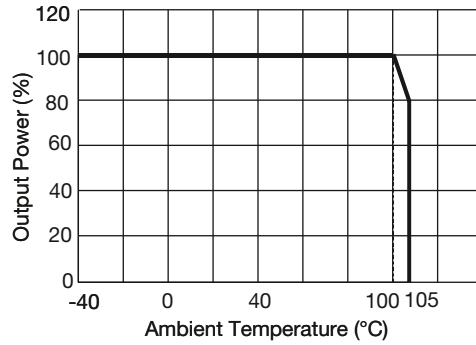

Efficiency vs Input Voltage (example IES0105S05)

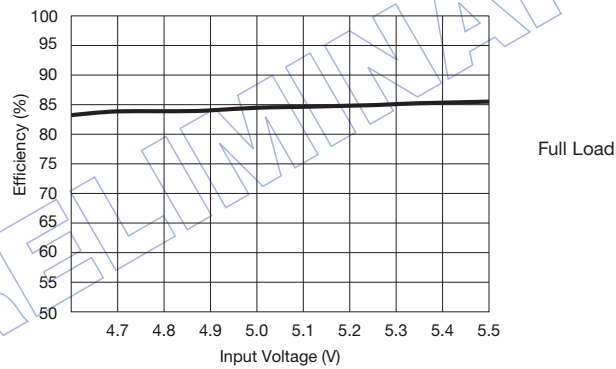

Efficiency vs Output Load (example IES0105S05)

