

Electronic housing - UEGH 27,5-SMD - 2757128

Please be informed that the data shown in this PDF Document is generated from our Online Catalog. Please find the complete data in the user's documentation. Our General Terms of Use for Downloads are valid (<http://phoenixcontact.com/download>)



Electronic housing, double level, fully equipped with 6 screw connections per side for one printed circuit board, for mounting of SMD components

The figure shows version UEGH 22,5

Your advantages

- ✓ Can accommodate up to two PCBs
- ✓ Can be snapped onto standard NS 35/7,5 and NS 35/15 DIN rails
- ✓ Efficient assembly thanks to overlapping housing parts
- ✓ Increased number of positions thanks to optional UEGM-MT FS slip-on connections

Key Commercial Data

| | |
|--------------------------------------|--------------------------------|
| Packing unit | 10 pc |
| Minimum order quantity | 10 pc |
| GTIN | |
| GTIN | 4017918139520 |
| Weight per Piece (excluding packing) | 66.610 g |
| Custom tariff number | 85369010 |
| Country of origin | Germany |
| Note | Made to Order (non-returnable) |

Technical data

General

| | |
|------------------|--------------------|
| Housing type | Complete housing |
| Housing material | Polyamide (PA 6.6) |
| Color (RAL) | green |

Ambient conditions

| | |
|---------------------------------|-------------------|
| Ambient temperature (operation) | -40 °C ... 105 °C |
|---------------------------------|-------------------|

Electronic housing - UEGH 27,5-SMD - 2757128

Technical data

Dimensions

| | |
|--------|----------|
| Length | 79 mm |
| Height | 106.7 mm |
| Width | 27.5 mm |
| Pitch | 5 mm |
| Depth | 79 mm |

Technical data

| | |
|----------------------------------|-------|
| Connection in acc. with standard | CUL |
| Nominal voltage U_N | 300 V |
| Nominal current I_N | 10 A |
| AWG/kcmil | 30-12 |
| Indicator1 | CUL1 |
| Power dissipation without gap | 5 W |
| Power dissipation with 20 mm gap | 7.5 W |
| Number of positions | 12 |

Connection data

| | |
|---------------------------------------|---------------------|
| Conductor cross section solid min. | 0.2 mm ² |
| Conductor cross section solid max. | 4 mm ² |
| Conductor cross section flexible min. | 0.2 mm ² |
| Conductor cross section flexible max. | 2.5 mm ² |
| Conductor cross section AWG min. | 24 |
| Conductor cross section AWG max. | 12 |
| Stripping length | 8 mm |

Standards and Regulations

| | |
|----------------------------------------|-----|
| Connection in acc. with standard | CUL |
| Flammability rating according to UL 94 | V2 |

Environmental Product Compliance

| | |
|------------|-----------------------------------------------------------------------------------------------------|
| | Lead 7439-92-1 |
| China RoHS | Environmentally Friendly Use Period = 50 |
| | For details about hazardous substances go to tab "Downloads", Category "Manufacturer's declaration" |

Drawings

Electronic housing - UEGH 27,5-SMD - 2757128

Dimensional drawing

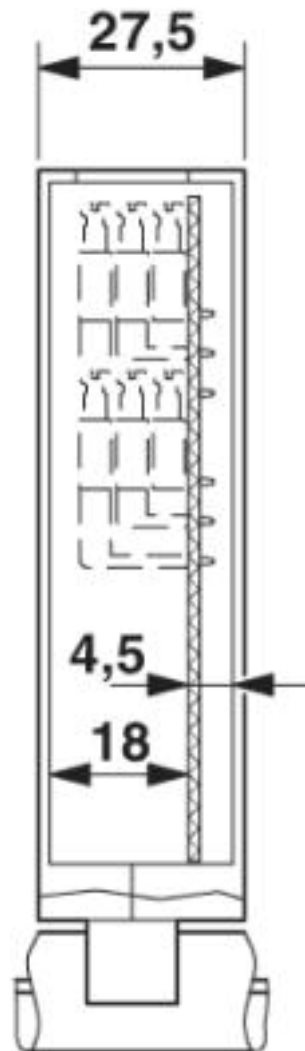

For 1 PCB, for SMD assembly of reverse side of PCB, 12 pos.

Electronic housing - UEGH 27,5-SMD - 2757128

Schematic diagram

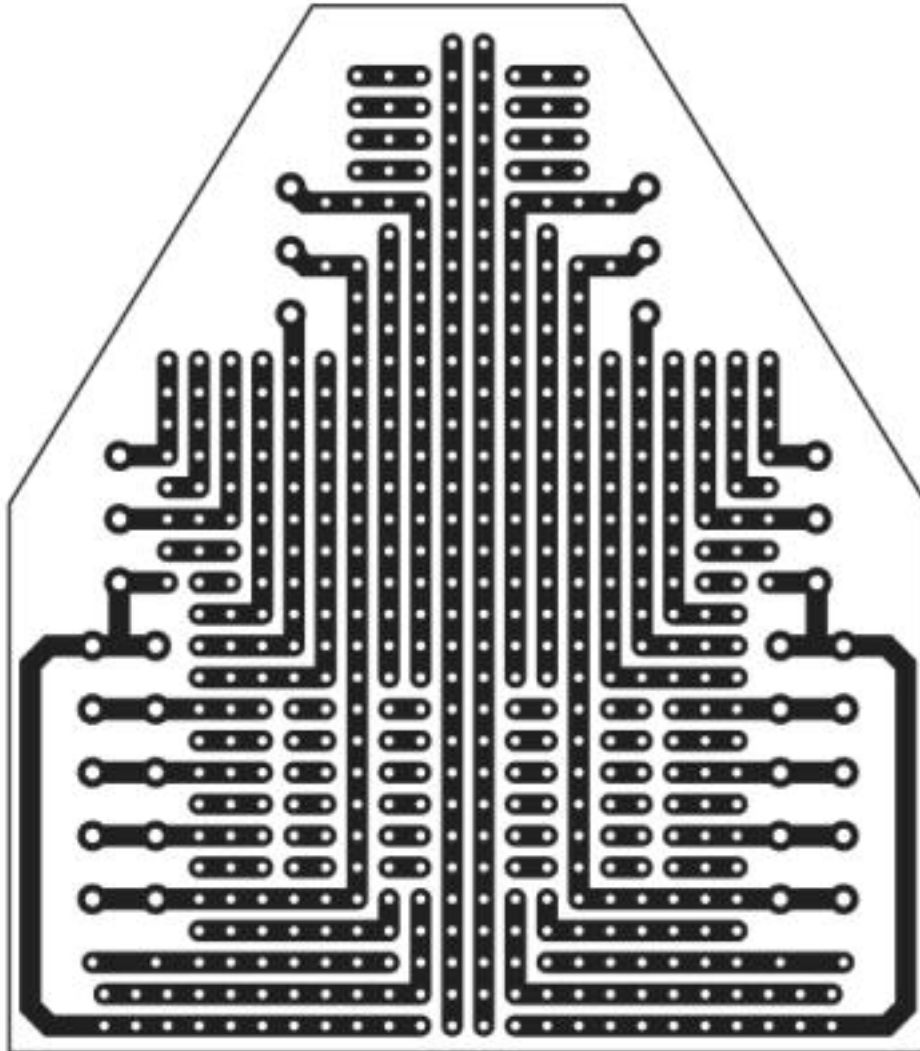

Electronic housing - UEGH 27,5-SMD - 2757128

Dimensional drawing

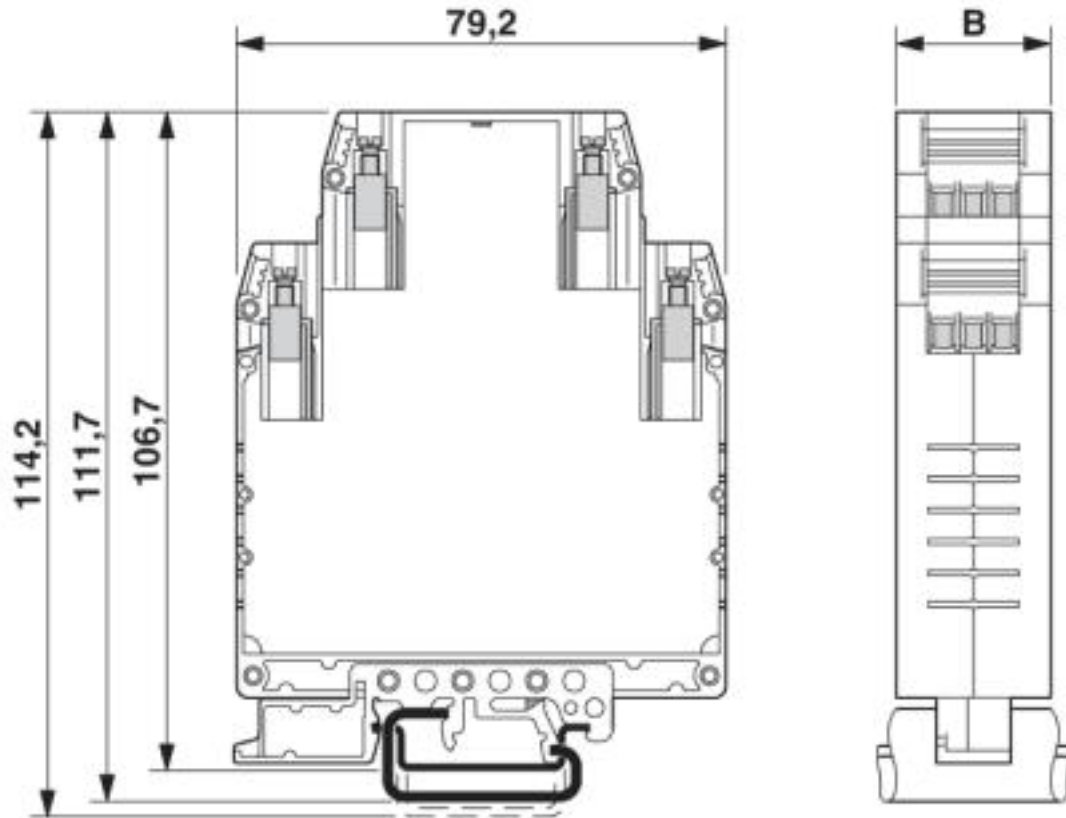

Electronic housing - UEGH 27,5-SMD - 2757128

Dimensional drawing

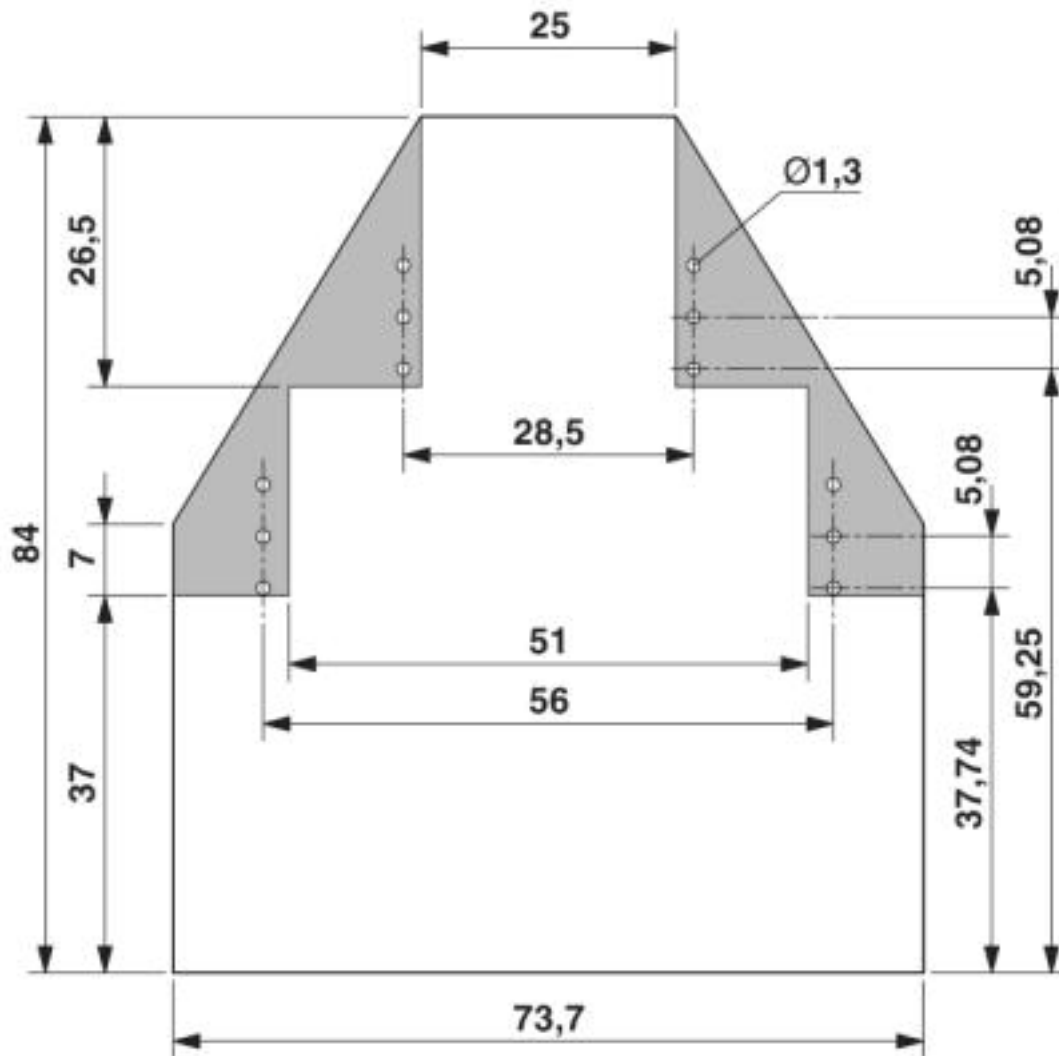

Classifications

eCl@ss

| | |
|------------|----------|
| eCl@ss 4.0 | 27180400 |
| eCl@ss 4.1 | 27180400 |
| eCl@ss 5.0 | 27180500 |
| eCl@ss 5.1 | 27180500 |
| eCl@ss 6.0 | 27180800 |
| eCl@ss 7.0 | 27182702 |
| eCl@ss 8.0 | 27182702 |
| eCl@ss 9.0 | 27182702 |

ETIM

| | |
|----------|----------|
| ETIM 2.0 | EC001031 |
|----------|----------|

Electronic housing - UEGH 27,5-SMD - 2757128

Classifications

ETIM

| | |
|----------|----------|
| ETIM 3.0 | EC001031 |
| ETIM 4.0 | EC001031 |
| ETIM 5.0 | EC001031 |
| ETIM 6.0 | EC001031 |
| ETIM 7.0 | EC001031 |

UNSPSC

| | |
|---------------|----------|
| UNSPSC 6.01 | 31261501 |
| UNSPSC 7.0901 | 31261501 |
| UNSPSC 11 | 31261501 |
| UNSPSC 12.01 | 31261501 |
| UNSPSC 13.2 | 31261501 |
| UNSPSC 18.0 | 31261501 |
| UNSPSC 19.0 | 31261501 |
| UNSPSC 20.0 | 31261501 |
| UNSPSC 21.0 | 31261501 |

Approvals

Approvals

Approvals

UL Recognized / EAC

Ex Approvals

Approval details

| | | | |
|---------------|--|-------------------------------------------------------------------------------------------------------------------------------------------------------|---------------|
| UL Recognized | | http://database.ul.com/cgi-bin/XYV/template/LISEXT/1FRAME/index.htm | FILE E 240868 |
|---------------|--|-------------------------------------------------------------------------------------------------------------------------------------------------------|---------------|

| | | |
|-----|--|---------|
| EAC | | B.01742 |
|-----|--|---------|

Accessories

Accessories

Bridge

Electronic housing - UEGH 27,5-SMD - 2757128

Accessories

Wire bridge - DB 50- 90 GY - 2820929

Wire bridge, color: gray



Phoenix Contact 2020 © - all rights reserved
<http://www.phoenixcontact.com>