

## Electronic housing - UEGM 27,5-SMD - 2757063

Please be informed that the data shown in this PDF Document is generated from our Online Catalog. Please find the complete data in the user's documentation. Our General Terms of Use for Downloads are valid (<http://phoenixcontact.com/download>)



Electronic housing, for PCB insertion, fully equipped with 3 screw connections per side, for mounting of SMD components

The figure shows version UEGM 22.5

### Your advantages

- ✓ Cost-effective series production, since the base element and the assembled PCB are soldered by machine
- ✓ Efficient assembly thanks to overlapping housing parts
- ✓ Can be snapped onto standard NS 35/7,5 and NS 35/15 DIN rails
- ✓ Complex electronic circuits can be integrated, with up to 24 connections on two levels



### Key Commercial Data

Packing unit	10 pc
Minimum order quantity	10 pc
GTIN	 4 017918 139537
GTIN	4017918139537
Weight per Piece (excluding packing)	57.750 g
Custom tariff number	85369010
Country of origin	Germany

### Technical data

#### General

Housing type	Complete housing
Housing material	Polyamide (PA 6.6)
Color (RAL)	green

#### Ambient conditions

Ambient temperature (operation)	-40 °C ... 105 °C
---------------------------------	-------------------

#### Dimensions

# Electronic housing - UEGM 27,5-SMD - 2757063

## Technical data

### Dimensions

Length	79 mm
Height	85.5 mm
Width	27.5 mm
Pitch	5 mm
Depth	79 mm

### Technical data

Number of positions	6
---------------------	---

### Connection data

Conductor cross section solid min.	0.2 mm <sup>2</sup>
Conductor cross section solid max.	4 mm <sup>2</sup>
Conductor cross section flexible min.	0.2 mm <sup>2</sup>
Conductor cross section flexible max.	2.5 mm <sup>2</sup>
Conductor cross section AWG min.	24
Conductor cross section AWG max.	12
Stripping length	8 mm

### Standards and Regulations

Flammability rating according to UL 94	V2
--	----

### Environmental Product Compliance

	Lead 7439-92-1
China RoHS	Environmentally Friendly Use Period = 50
	For details about hazardous substances go to tab "Downloads", Category "Manufacturer's declaration"

## Drawings

## Electronic housing - UEGM 27,5-SMD - 2757063

Dimensional drawing

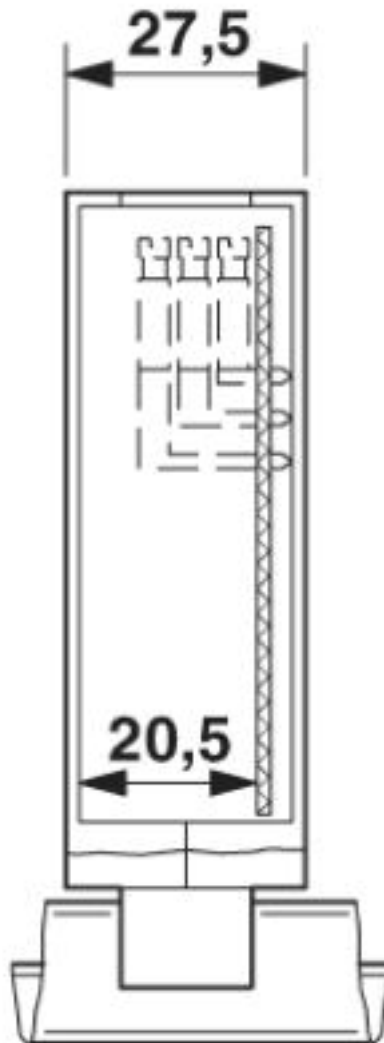

UEGM 25... und UEGM 27,5-SMD with 1 PCB, 6 positions or 12 positions (FS/FS)

## Electronic housing - UEGM 27,5-SMD - 2757063

Exploded view

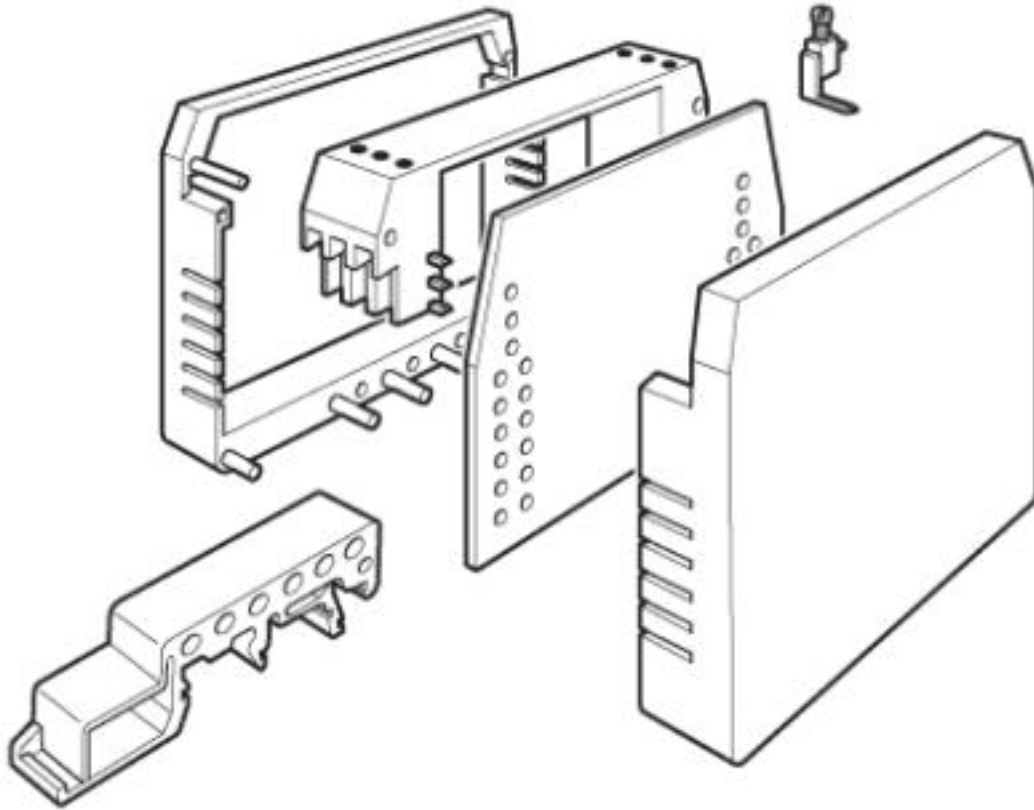

# Electronic housing - UEGM 27,5-SMD - 2757063

Dimensional drawing

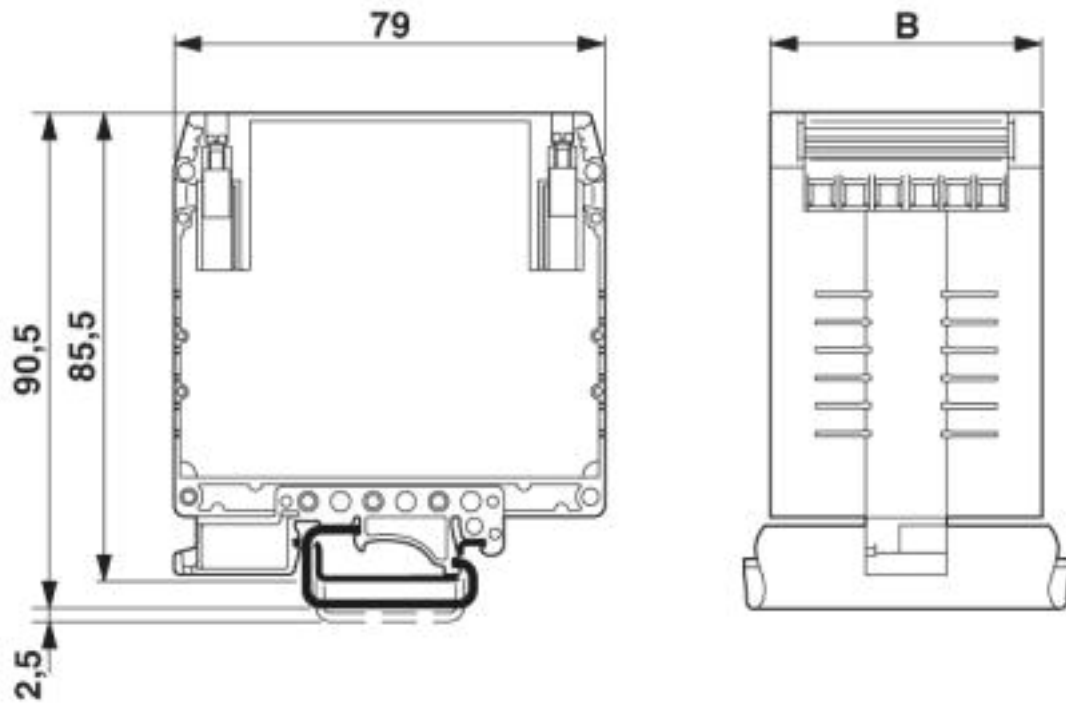

# Electronic housing - UEGM 27,5-SMD - 2757063

Dimensional drawing

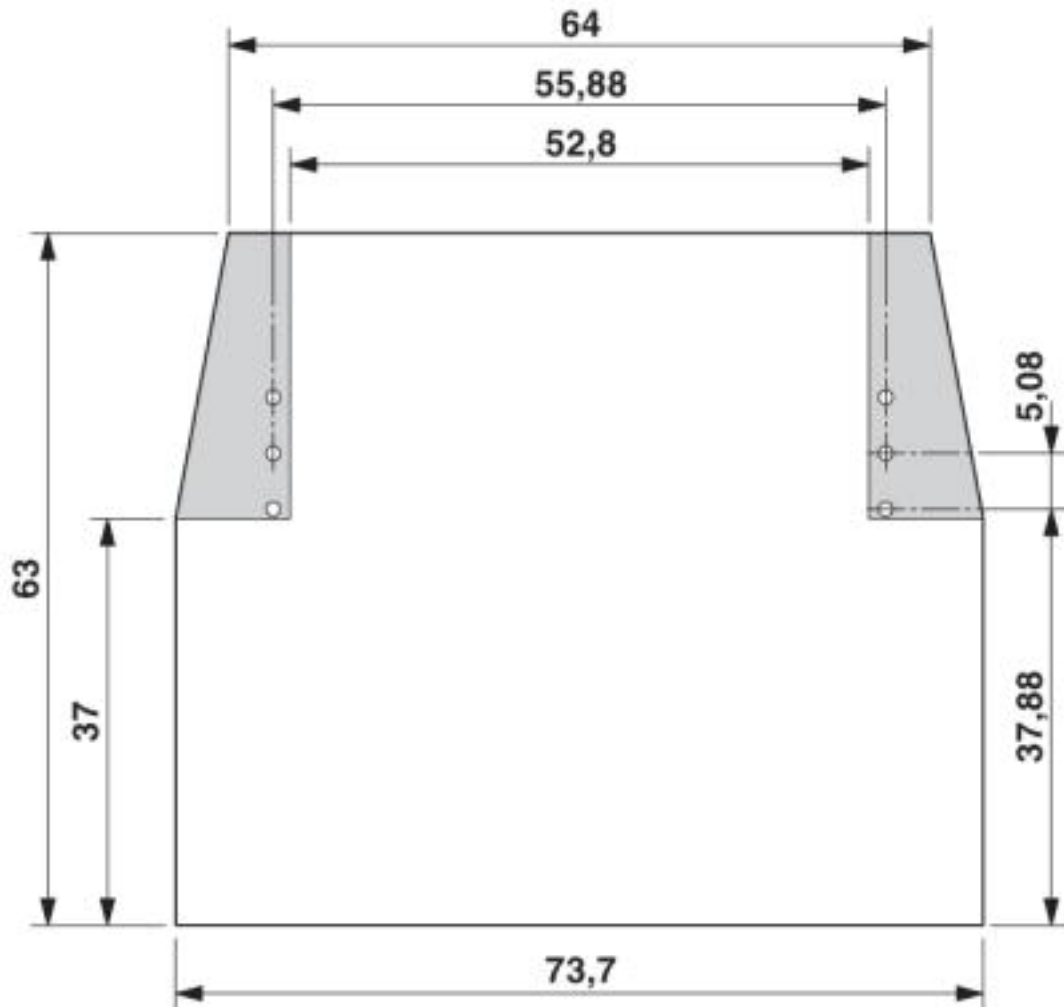

# Electronic housing - UEGM 27,5-SMD - 2757063

Schematic diagram

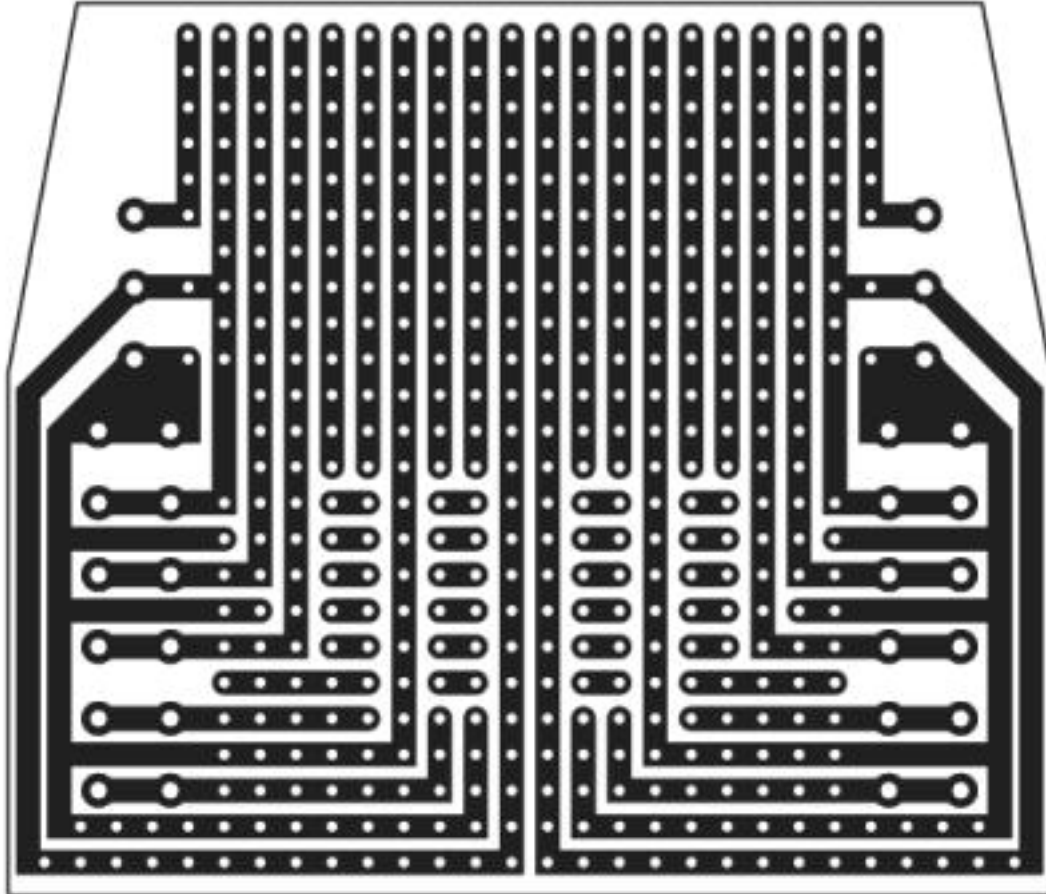

## Classifications

### eCl@ss

eCl@ss 4.0	27180400
eCl@ss 4.1	27180400
eCl@ss 5.0	27180500
eCl@ss 5.1	27180500
eCl@ss 6.0	27180800
eCl@ss 7.0	27182702
eCl@ss 8.0	27182702
eCl@ss 9.0	27182702

### ETIM

ETIM 2.0	EC001031
ETIM 3.0	EC001031
ETIM 4.0	EC001031
ETIM 5.0	EC001031

# Electronic housing - UEGM 27,5-SMD - 2757063

## Classifications

### ETIM

ETIM 6.0	EC001031
ETIM 7.0	EC001031

### UNSPSC

UNSPSC 6.01	31261501
UNSPSC 7.0901	31261501
UNSPSC 11	31261501
UNSPSC 12.01	31261501
UNSPSC 13.2	31261501
UNSPSC 18.0	31261501
UNSPSC 19.0	31261501
UNSPSC 20.0	31261501
UNSPSC 21.0	31261501

## Approvals

### Approvals

Approvals

UL Recognized / EAC

Ex Approvals

### Approval details

UL Recognized		<a href="http://database.ul.com/cgi-bin/XYV/template/LISEXT/1FRAME/index.htm">http://database.ul.com/cgi-bin/XYV/template/LISEXT/1FRAME/index.htm</a>	FILE E 240868
---------------	--	---	---------------

EAC		B.01742
-----	--	---------

## Accessories

Accessories

Bridge



## Electronic housing - UEGM 27,5-SMD - 2757063

### Accessories

Wire bridge - DB 50- 90 GY - 2820929

Wire bridge, color: gray



---

Phoenix Contact 2020 © - all rights reserved  
<http://www.phoenixcontact.com>