

Electronic housing - UEGM 40/2 BU - 2792604

Please be informed that the data shown in this PDF Document is generated from our Online Catalog. Please find the complete data in the user's documentation. Our General Terms of Use for Downloads are valid (<http://phoenixcontact.com/download>)



Electronic housing, fully equipped with 6 screw connections per side for two PCBs

The figure shows a green version



Key Commercial Data

Packing unit	10 pc
GTIN	 4 017918 365318
GTIN	4017918365318
Weight per Piece (excluding packing)	71.090 g
Custom tariff number	85369010
Country of origin	Germany

Technical data

General

Housing type	Complete housing
Housing material	Polyamide (PA 6.6)
Color (RAL)	blue (5015)

Ambient conditions

Ambient temperature (operation)	-40 °C ... 105 °C
---------------------------------	-------------------

Dimensions

Length	79 mm
Width	40 mm
Pitch	5 mm
Depth	79 mm

Technical data

Connection in acc. with standard	CUL
----------------------------------	-----

Electronic housing - UEGM 40/2 BU - 2792604

Technical data

Technical data

Nominal voltage U_N	300 V
Nominal current I_N	10 A
AWG/kcmil	30-12
Indicator1	CUL1
Power dissipation without gap	5.2 W
Power dissipation with 20 mm gap	11.2 W
Number of positions	12

Connection data

Conductor cross section solid min.	0.2 mm ²
Conductor cross section solid max.	4 mm ²
Conductor cross section flexible min.	0.2 mm ²
Conductor cross section flexible max.	2.5 mm ²
Conductor cross section AWG min.	24
Conductor cross section AWG max.	12
Stripping length	8 mm

Standards and Regulations

Connection in acc. with standard	CUL
Flammability rating according to UL 94	V2

Environmental Product Compliance

	Lead 7439-92-1
China RoHS	Environmentally Friendly Use Period = 50
	For details about hazardous substances go to tab "Downloads", Category "Manufacturer's declaration"

Drawings

Electronic housing - UEGM 40/2 BU - 2792604

Dimensional drawing

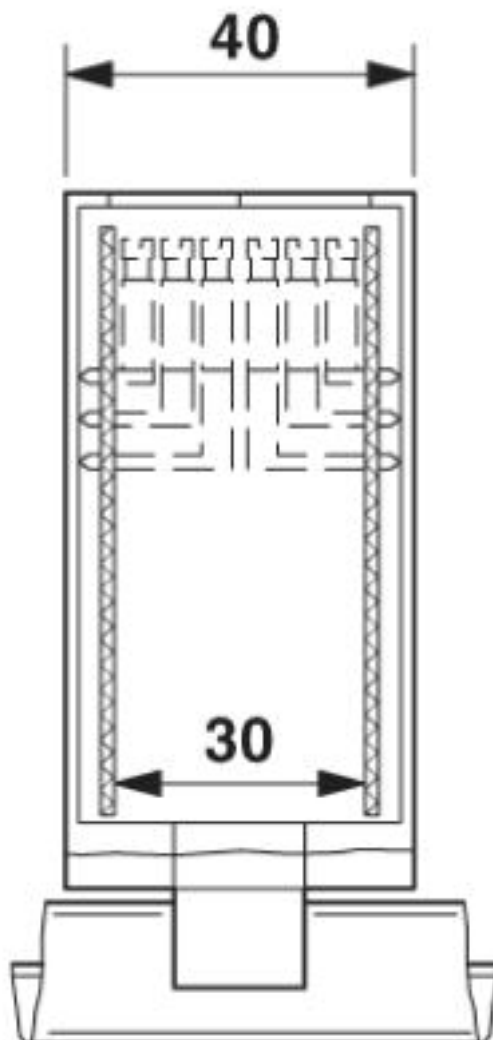

Electronic housing - UEGM 40/2 BU - 2792604

Exploded view

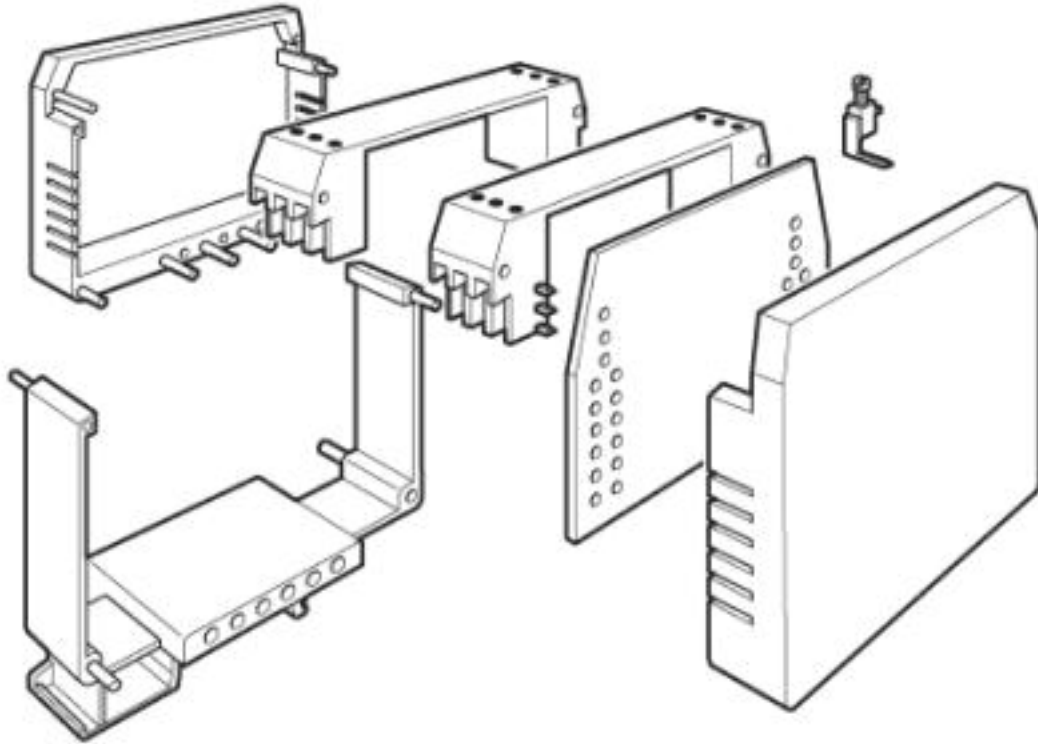

Dimensional drawing

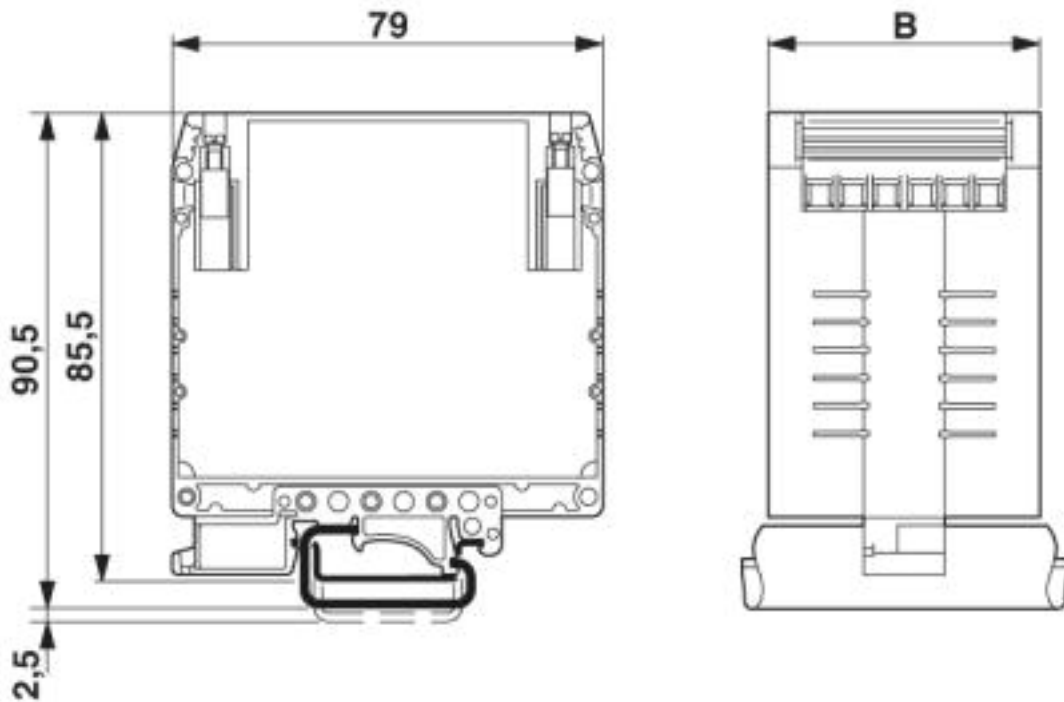

Electronic housing - UEGM 40/2 BU - 2792604

Dimensional drawing

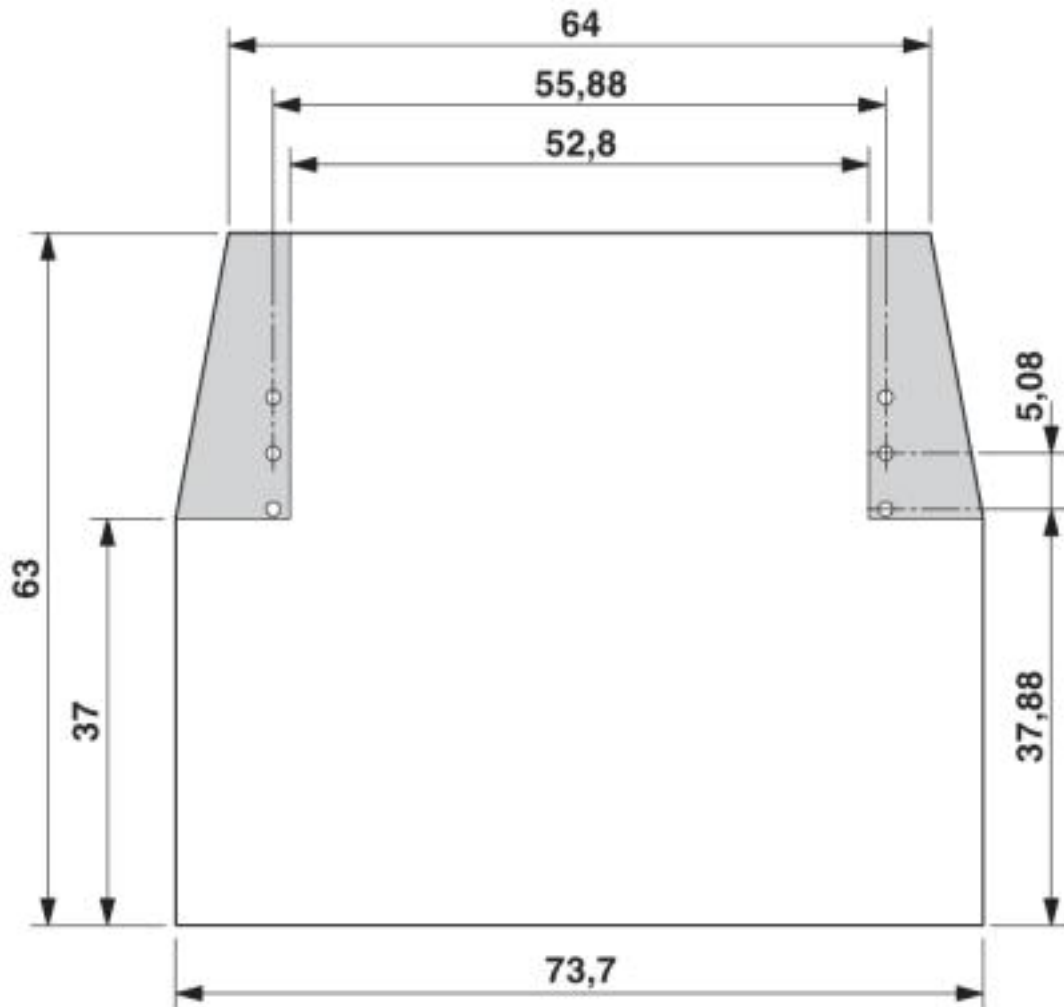

Electronic housing - UEGM 40/2 BU - 2792604

Schematic diagram

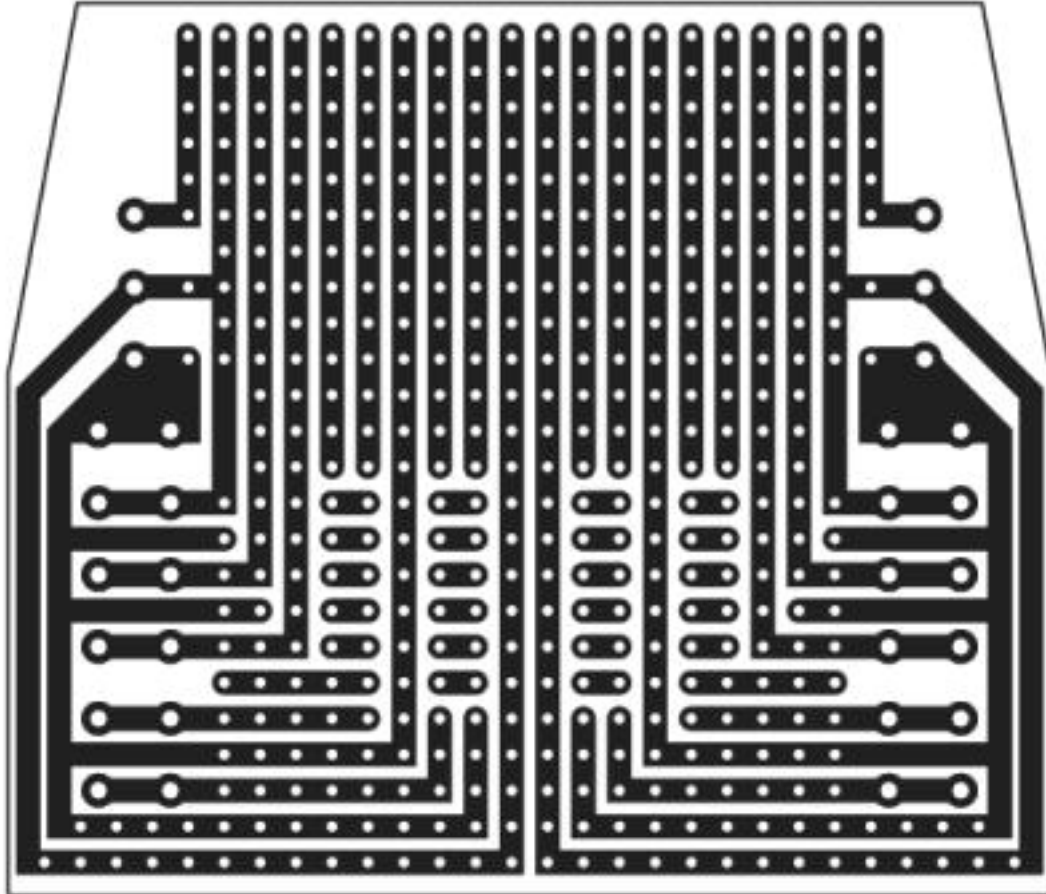

Classifications

eCl@ss

eCl@ss 4.0	27180400
eCl@ss 4.1	27180400
eCl@ss 5.0	27180500
eCl@ss 5.1	27180500
eCl@ss 6.0	27180800
eCl@ss 7.0	27182702
eCl@ss 8.0	27182702
eCl@ss 9.0	27182702

ETIM

ETIM 2.0	EC001031
ETIM 3.0	EC001031
ETIM 4.0	EC001031
ETIM 5.0	EC001031

Electronic housing - UEGM 40/2 BU - 2792604

Classifications

ETIM

ETIM 6.0	EC001031
ETIM 7.0	EC001031

UNSPSC

UNSPSC 6.01	31261501
UNSPSC 7.0901	31261501
UNSPSC 11	31261501
UNSPSC 12.01	31261501
UNSPSC 13.2	31261501
UNSPSC 18.0	31261501
UNSPSC 19.0	31261501
UNSPSC 20.0	31261501
UNSPSC 21.0	31261501

Approvals

Approvals

Approvals

UL Recognized / EAC / cULus Recognized

Ex Approvals

Approval details

UL Recognized		http://database.ul.com/cgi-bin/XYV/template/LISEXT/1FRAME/index.htm	FILE E 240868
---------------	---	---	---------------

EAC		B.01742
-----	---	---------

cULus Recognized		http://database.ul.com/cgi-bin/XYV/template/LISEXT/1FRAME/index.htm	E60425-19770427
Nominal voltage UN	300 V		
Nominal current IN	10 A		
mm²/AWG/kcmil	30-12		

Electronic housing - UEGM 40/2 BU - 2792604

Accessories

Accessories

Bridge

Wire bridge - DB 50- 90 GY - 2820929

Wire bridge, color: gray

