

# DIN rail mounting frame - HC-CIF-B24-HFWL-PL - 1424337

Please be informed that the data shown in this PDF Document is generated from our Online Catalog. Please find the complete data in the user's documentation. Our General Terms of Use for Downloads are valid (<http://phoenixcontact.com/download>)



HEAVYCON DIN rail mounting frame, for type B24 contact inserts



## Key Commercial Data

Packing unit	1 pc
GTIN	
GTIN	4055626370750
Weight per Piece (excluding packing)	51.400 g
Custom tariff number	85389099
Country of origin	China

## Technical data

### Dimensions

Length	170 mm
Width	42 mm
Height	61 mm

### Ambient conditions

Ambient temperature (operation)	-40 °C ... 125 °C
---------------------------------	-------------------

### General

Size	B24
Material	PC
Flammability rating according to UL 94	V0
Color	traffic grey
Note	for B24, BB48, DD108, HV10 contact inserts and B24 module frame

### Standards and Regulations

Flammability rating according to UL 94	V0
--	----

# DIN rail mounting frame - HC-CIF-B24-HFWL-PL - 1424337

## Technical data

### Environmental Product Compliance

REACH SVHC	Lead 7439-92-1
China RoHS	Environmentally Friendly Use Period = 50
	For details about hazardous substances go to tab "Downloads", Category "Manufacturer's declaration"

## Drawings

Dimensional drawing

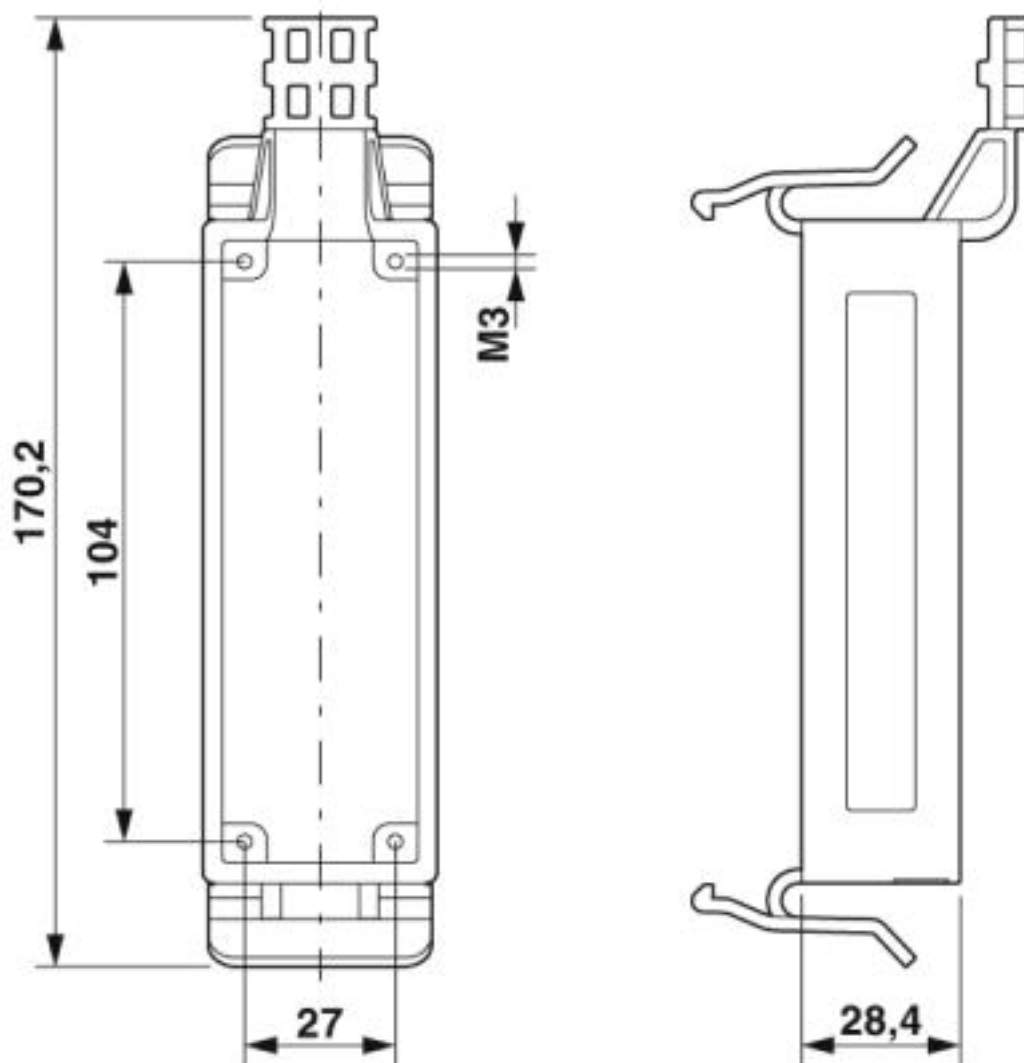

Dimensional drawing

# DIN rail mounting frame - HC-CIF-B24-HFWL-PL - 1424337

## Classifications

### eCl@ss

eCl@ss 5.1	27143424
eCl@ss 6.0	27261200
eCl@ss 7.0	27440206
eCl@ss 8.0	27440206
eCl@ss 9.0	27440210

### ETIM

ETIM 5.0	EC002310
ETIM 6.0	EC002310
ETIM 7.0	EC002310

## Approvals

### Approvals

#### Approvals

UL Recognized / cUL Recognized / EAC / cULus Recognized

#### Ex Approvals

### Approval details

UL Recognized		<a href="http://database.ul.com/cgi-bin/XYV/template/LISEXT/1FRAME/index.htm">http://database.ul.com/cgi-bin/XYV/template/LISEXT/1FRAME/index.htm</a>	E118976
---------------	--	---	---------

cUL Recognized		<a href="http://database.ul.com/cgi-bin/XYV/template/LISEXT/1FRAME/index.htm">http://database.ul.com/cgi-bin/XYV/template/LISEXT/1FRAME/index.htm</a>	E118976
----------------	--	---	---------

EAC		EAC-Zulassung
-----	--	---------------

cULus Recognized	
------------------	--

## Accessories

### Accessories

## DIN rail mounting frame - HC-CIF-B24-HFWL-PL - 1424337

### Accessories

#### Adapter

Adapter insert - HC-CIF-D25-AIWS-SM-NI - 1424341



Adapter insert, type: D25

---

### Additional products

DIN rail mounting frame - HC-CIF-B06-24-BFAFL-PL - 1424338



DIN rail mounting frame, type: B6 - B24, for contact inserts