

## Panel feed-through - Q 0,75/3FL/ 9-M16KU-ESA BK - 1641497

Please be informed that the data shown in this PDF Document is generated from our Online Catalog. Please find the complete data in the user's documentation. Our General Terms of Use for Downloads are valid (<http://phoenixcontact.com/download>)



QUICKON panel feed-through, for external wall mounting with manual solder/slip-on connection, 2.8 x 0.8 mm, 3-pos.



### Key Commercial Data

Packing unit	10 pc
Minimum order quantity	10 pc
GTIN	 4 017918 219581
GTIN	4017918219581
Weight per Piece (excluding packing)	16.200 g
Custom tariff number	85369010
Country of origin	Poland
Note	Made to Order (non-returnable)

### Technical data

#### General

Connection	If the conductor is reconnected, it must be cut off above the last contact point. QUICKON components may only be operated when under no load.
Color	black
Connection method	QUICKON connection Manual solder/slip-on connection; 2.8 x 0.8 mm
Number of positions	3
Wrench size, union nut	19 mm
Tightening torque, union nut	2.5 Nm
Wrench size, contact carrier	19 mm
Tightening torque contact carrier	3.75 Nm
Tightening torque, counter nut	3.75 Nm
Number of connections	3

# Panel feed-through - Q 0,75/3FL/ 9-M16KU-ESA BK - 1641497

## Technical data

### General

Conductor cross section flexible min.	0.34 mm <sup>2</sup>
Conductor cross section flexible max.	0.75 mm <sup>2</sup>
Conductor cross section solid min.	0.75 mm <sup>2</sup>
Conductor cross section solid max.	1 mm <sup>2</sup>
Conductor cross section AWG min.	18
Conductor cross section AWG max.	16

### Cabel

Structure of individual litz in acc. with VDE 0295 / smallest wire diameter	Class 2-6 // 0.34 mm <sup>2</sup> : 0.1 mm; 0.5 - 0.75 mm <sup>2</sup> : 0.15 mm
Wire insulation material	PVC / PE
Wire diameter including insulation	>= 2.5 mm
External cable diameter	5 mm ... 6.8 mm
Position marking	1, 2, 3

### Ambient conditions

Degree of protection	IP65
	IP67
Ambient temperature (operation)	-25 °C ... 80 °C (Specifications of the cable manufacturer must be observed.)
	-25 °C ... 50 °C (when the conductor is connected. Specifications of the cable manufacturer must also be observed.)
Temperature when conductor connected	-5 °C ... 50 °C (specifications of the cable manufacturer must also be observed)

### Electrical characteristics

Nominal current I <sub>N</sub>	9 A
Rated current	9 A
Rated voltage (III/3)	160 V
Note on the rated voltage (III/3)	with insulating sleeve
Rated voltage (III/2)	160 V
Note on the rated voltage (III/2)	with insulating sleeve
Rated voltage (II/2)	320 V
Note on the rated voltage (II/2)	with insulating sleeve
Rated surge voltage (III/3)	4 kV
Rated surge voltage (III/2)	4 kV
Rated surge voltage (II/2)	4 kV

### Mechanical characteristics

QUICKON connectability	max. 10 (if the conductor is connected more than once, seal and cap may need to be replaced.)
PC QUICKON thread type	M16 x 1.5
Impact category	3
Category of shock impact	IK07

### Material data

# Panel feed-through - Q 0,75/3FL/ 9-M16KU-ESA BK - 1641497

## Technical data

### Material data

Contact material	CuZn
Contact surface material	Tin-plated
Contact carrier material	PA
Insulating material	PA
Flammability rating according to UL 94	V0
Overvoltage category	III
Degree of pollution	3
Suitable for outdoor use	f1 (UL 746C)

### Standards and Regulations

Connection in acc. with standard	CUL
Flammability rating according to UL 94	V0

### Environmental Product Compliance

China RoHS	Environmentally Friendly Use Period = 50
	For details about hazardous substances go to tab "Downloads", Category "Manufacturer's declaration"

## Drawings

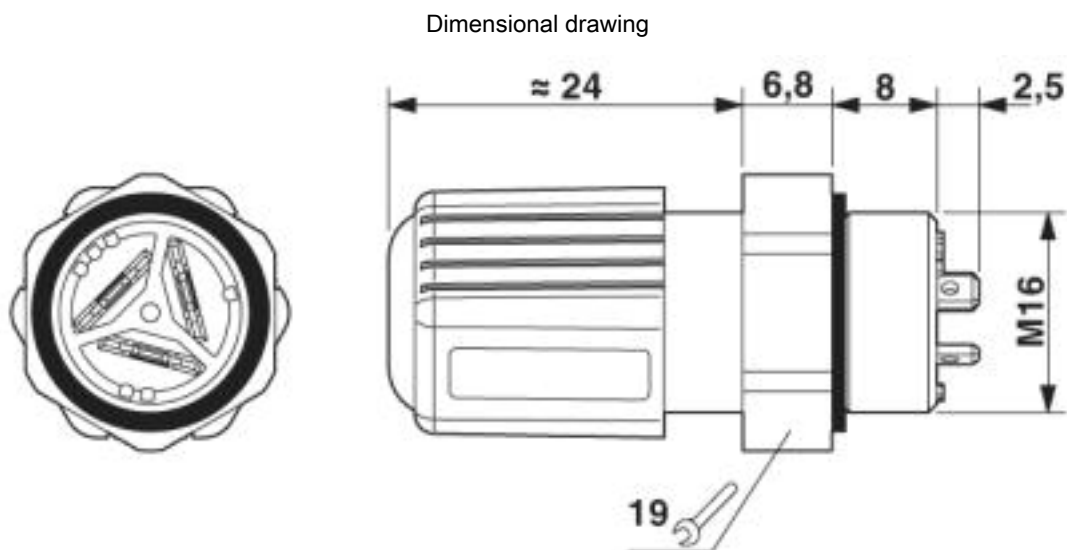

## Classifications

### eCl@ss

eCl@ss 4.0	27140800
eCl@ss 4.1	27140800
eCl@ss 5.0	27143400
eCl@ss 5.1	27143400

# Panel feed-through - Q 0,75/3FL/ 9-M16KU-ESA BK - 1641497

## Classifications

### eCl@ss

eCl@ss 6.0	27143400
eCl@ss 7.0	27440602
eCl@ss 8.0	27440602
eCl@ss 9.0	27440602

### ETIM

ETIM 2.0	EC001297
ETIM 3.0	EC000516
ETIM 4.0	EC000516
ETIM 5.0	EC002566
ETIM 6.0	EC002566
ETIM 7.0	EC002566

### UNSPSC

UNSPSC 6.01	30211923
UNSPSC 7.0901	39121522
UNSPSC 11	39121522
UNSPSC 12.01	39121522
UNSPSC 13.2	39121413
UNSPSC 18.0	39121522
UNSPSC 19.0	39121522
UNSPSC 20.0	39121522
UNSPSC 21.0	39121522

## Approvals

### Approvals

#### Approvals

UL Recognized / cUL Recognized / EAC / EAC / EAC / cULus Recognized

#### Ex Approvals

### Approval details

UL Recognized		<a href="http://database.ul.com/cgi-bin/XYV/template/LISEXT/1FRAME/index.htm">http://database.ul.com/cgi-bin/XYV/template/LISEXT/1FRAME/index.htm</a>	FILE E 118976
Nominal voltage UN	250 V		

# Panel feed-through - Q 0,75/3FL/ 9-M16KU-ESA BK - 1641497

## Approvals

Nominal current IN	9 A
--------------------	-----

cUL Recognized		<a href="http://database.ul.com/cgi-bin/XYV/template/LISEXT/1FRAME/index.htm">http://database.ul.com/cgi-bin/XYV/template/LISEXT/1FRAME/index.htm</a>	FILE E 118976
Nominal voltage UN	250 V		
Nominal current IN	6 A		

EAC		RU C-DE.AI30.B.01102
-----	--	----------------------

EAC		RU C-DE.A*30.B.01102
-----	--	----------------------

EAC		RU C-DE.BL08.B.00511
-----	--	----------------------

cULus Recognized	
------------------	--

## Accessories

### Accessories

#### Electronics pliers

Diagonal cutter - MICROFOX-SB - 1212489



Electronic diagonal cutter, round head, without chamfer, with opening spring, mirror-polished and oiled, 2-component grip, cutting capacity: soft 0.2 - 2.0 mm; medium hard 1.2 mm; hard 0.5 mm diameter

#### Insulating sleeve

## Panel feed-through - Q 0,75/3FL/ 9-M16KU-ESA BK - 1641497

### Accessories

Insulating sleeve - PT/FS 2,8 - 1406700

Insulating sleeve, as touch protection, slide onto the conductor before for 2.8 slip-on sleeves



---

### Mounting material

Nut - Q-MU M16 - 1640692



Nut (plastic) to lock the contact carrier from the inside of the device

---

Mounting material - Q SET- 9 DI/KR - 1640362



Seal/Collar replacement set Pg9

---

### Sealing plugs

Filler plugs - Q-PROT 9/11 - 1670235



Closing cap for Pg9/Pg11 to close unoccupied connections

---

### Socket spanner

Socket wrench - QSS 19 - 1670895



Socket wrench, for tightening and unscrewing the QUICKON union nut, wrench size 19 mm

