

Electronic housing - HC-ALU 6-100,5 PROFILE 150 - 2200898

Please be informed that the data shown in this PDF Document is generated from our Online Catalog. Please find the complete data in the user's documentation. Our General Terms of Use for Downloads are valid (<http://phoenixcontact.com/download>)

Profile housing, length: 150 mm, Lower part, color: aluminum color, width: 121 mm, height: 32.8 mm



Your advantages

- ✔ Item is from the HC-ALU product range
- ✔ Aluminum press-drawn section
- ✔ Available in lengths from 100 mm ... 1000 mm, can be individually cut to any length
- ✔ Available in overall widths 53.5 mm ... 161 mm
- ✔ Degree of protection up to IP65
- ✔ Usable as handheld and wall housing
- ✔ Optional EMC seals available

Key Commercial Data

Packing unit	1 pc
GTIN	
GTIN	4046356715850
Weight per Piece (excluding packing)	304.400 g
Custom tariff number	76042100
Country of origin	Hungary
Note	Made to Order (non-returnable)

Technical data

General

Housing type	Profile housing
Housing material	Aluminum
Color (RAL)	aluminum color

Ambient conditions

Ambient temperature (operation)	-40 °C ... 85 °C
---------------------------------	------------------

Electronic housing - HC-ALU 6-100,5 PROFILE 150 - 2200898

Technical data

Dimensions

Length	150 mm
Height	32.8 mm
Width	121 mm
Depth	100.5 mm

Drawings

Dimensional drawing

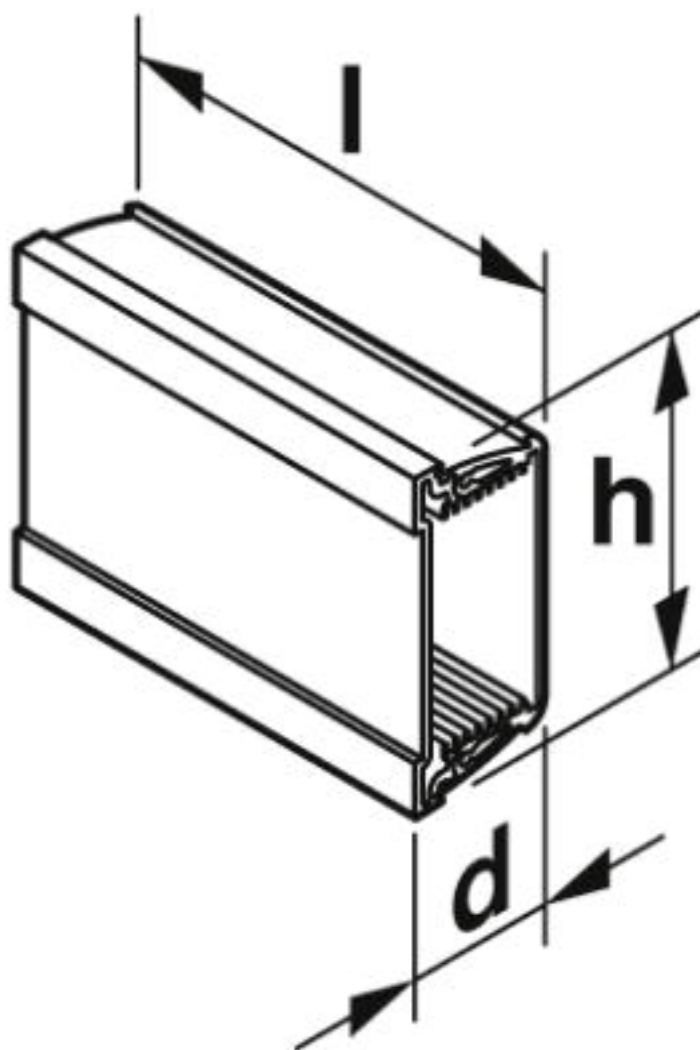

Electronic housing - HC-ALU 6-100,5 PROFILE 150 - 2200898

Dimensional drawing

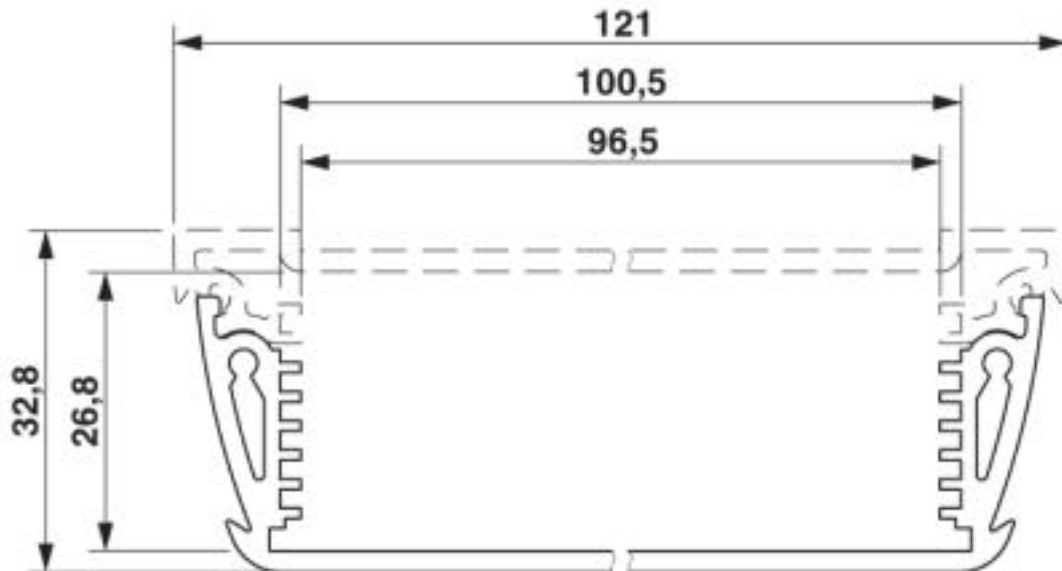

Classifications

eCl@ss

eCl@ss 10.0.1	27182701
eCl@ss 4.0	27180400
eCl@ss 4.1	27180400
eCl@ss 5.0	27180500
eCl@ss 5.1	27180500
eCl@ss 6.0	27182000
eCl@ss 7.0	27182701
eCl@ss 8.0	27182701
eCl@ss 9.0	27182701

ETIM

ETIM 3.0	EC001031
ETIM 4.0	EC000721
ETIM 5.0	EC002779
ETIM 6.0	EC002779
ETIM 7.0	EC002779

UNSPSC

UNSPSC 6.01	31261501
UNSPSC 7.0901	31261501
UNSPSC 11	31261501
UNSPSC 12.01	31261501
UNSPSC 13.2	31261501

Electronic housing - HC-ALU 6-100,5 PROFILE 150 - 2200898

Classifications

UNSPSC

UNSPSC 18.0	31261501
UNSPSC 19.0	31261501
UNSPSC 20.0	31261501
UNSPSC 21.0	31261501

Accessories

Accessories

Mounting material

Mounting material - HC-ALU 6 DECO 150 GY - 2200915



Decorative strip for HC-ALU panel mounting base

Mounting material - HC-ALU 6 MOUNT 150 GY - 2200912



Mounting foot for panel mounting the HC-ALU panel mounting base

Tool set

Tool set - SF-TXH SET - 1212538



Screwdriver set, Torx[®] with drill bit, 6-part, incl. rack, contents: TX 8 x 60; TX 10 x 80; TX 15 x 80; TX 20 x 100; TX 25 x 100; TX 30 x 115

Tool set - SF-M SET - 1212543



Bit screwdriver set with quick-action chuck, 89 mm long slotted/crosshead (PZ and PH)/hex/Torx[®] bits, 17-part, in folding belt pouch, contents: PH 1,2,3 x 89; PZ 1,2,3 x 89; SL 1.5 x 5.5 x 89; TX 10-30 x 89; SW 3,4,5,6 x 89

Necessary add-on products

Electronic housing - HC-ALU 6-100,5 PROFILE 150 - 2200898

Accessories

End cover - HC-ALU 6-100,5 COVER GY - 2200901



Profile housing, length: 15 mm, Side part, color: gray, width: 124.4 mm, height: 36.2 mm

End cover - HC-ALU 6-100,5 DKL-COVER GY - 2201123



Profile housing, length: 15 mm, Side part, color: gray, width: 124.4 mm, height: 36.2 mm

Seal - HC-ALU 6-100,5 SEAL EMC - 2200909



EMC seal for HC-ALU panel mounting base
