

Side element - UM 45-SEK - 2959311

Please be informed that the data shown in this PDF Document is generated from our Online Catalog. Please find the complete data in the user's documentation. Our General Terms of Use for Downloads are valid (<http://phoenixcontact.com/download>)



Side element, with cable fixture, 6 mm wide, cables fixed with cable ties, these are not included in the scope of delivery.

The figure shows version UM 25-SEK

Your advantages

- UM ...-SES lateral element offers options for labeling with Phoenix Contact marking material
- Fast mounting
- Inexpensive as a result of reducing the number of separate housing parts
- Flexible size and shape
- High degree of mechanical stability by screwing the lateral elements to the profile
- Cable fixing by means of UM ...-SEK lateral element (fixed using cable binders, not supplied as standard)
- The UMK-BF mounting flange enables modules to be mounted directly on the wall



Key Commercial Data

Packing unit	10 pc
Minimum order quantity	10 pc
GTIN	
GTIN	4017918104443
Weight per Piece (excluding packing)	4.990 g
Custom tariff number	39269097
Country of origin	Poland
Note	Made to Order (non-returnable)

Technical data

Product properties

Brief article description	Side element
Type	UM 45-SEK
Order No.	2959311

Side element - UM 45-SEK - 2959311

Technical data

Product properties

Housing type	Press-drawn section housings
Type	Lateral element

Dimensions

Depth [d]	45 mm
-------------	-------

Material specifications

Housing material	PA
Color (RAL)	green
Flammability rating according to UL 94	V0

Packaging specifications

Pieces per package	10
Denomination packing units	Pcs.

Environmental Product Compliance

China RoHS	Environmentally friendly use period: unlimited = EFUP-e
	No hazardous substances above threshold values

Drawings

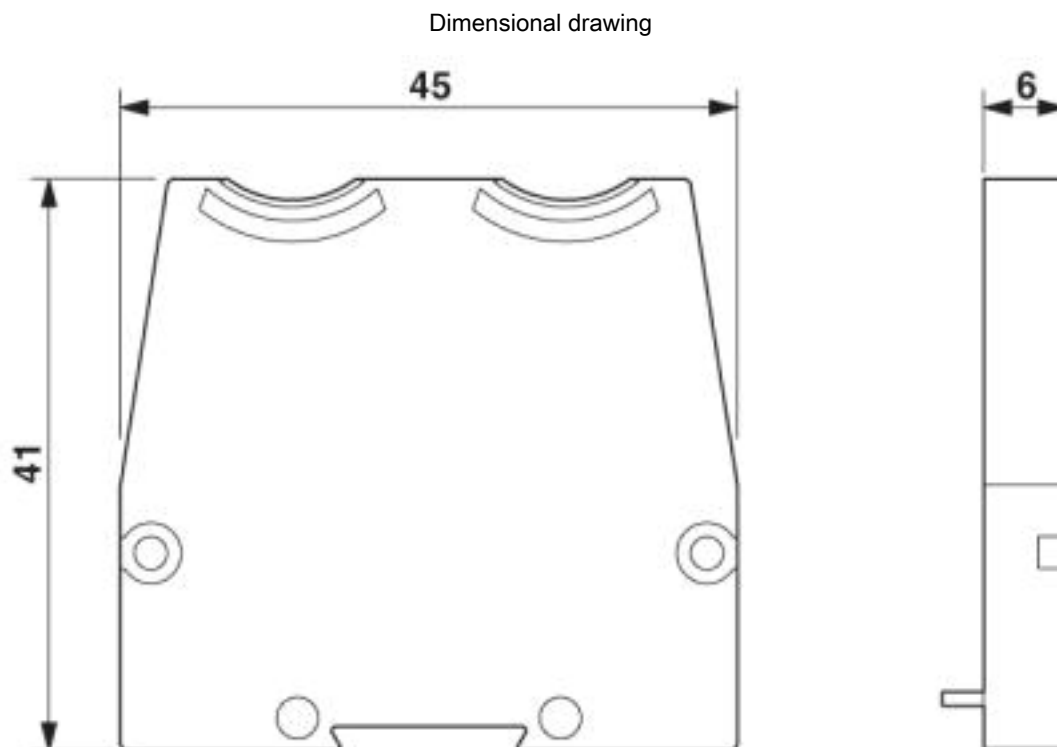

Side element - UM 45-SEK - 2959311

Classifications

eCl@ss

eCl@ss 10.0.1	27182701
eCl@ss 4.0	27180400
eCl@ss 4.1	27180400
eCl@ss 5.0	27180500
eCl@ss 5.1	27180500
eCl@ss 6.0	27180800
eCl@ss 7.0	27182701
eCl@ss 8.0	27182701
eCl@ss 9.0	27182701

ETIM

ETIM 2.0	EC001031
ETIM 3.0	EC001031
ETIM 4.0	EC001031
ETIM 5.0	EC002779
ETIM 6.0	EC002779
ETIM 7.0	EC002779

UNSPSC

UNSPSC 6.01	31261501
UNSPSC 7.0901	31261501
UNSPSC 11	31261501
UNSPSC 12.01	31261501
UNSPSC 13.2	31261501
UNSPSC 18.0	31261501
UNSPSC 19.0	31261501
UNSPSC 20.0	31261501
UNSPSC 21.0	31261501

Approvals

Approvals

Approvals

UL Recognized

Ex Approvals

Approval details

Side element - UM 45-SEK - 2959311

Approvals

UL Recognized



<http://database.ul.com/cgi-bin/XYV/template/LISEXT/1FRAME/index.htm>

FILE E 240868