

Extension module - PLC-APT-PT100-IN - 2906919

Please be informed that the data shown in this PDF Document is generated from our Online Catalog. Please find the complete data in the user's documentation. Our General Terms of Use for Downloads are valid (<http://phoenixcontact.com/download>)



Pt 100/Pt1000 temperature transducer for PLC logic logic modules (Generation 2 only), single-channel, signal type (Pt 100, Pt 1000) can be configured via DIP switch, Push-in connection



Key Commercial Data

Packing unit	1 pc
GTIN	 4 055626 155500
GTIN	4055626155500
Weight per Piece (excluding packing)	50.300 g
Custom tariff number	85389099
Country of origin	Germany

Technical data

Dimensions

Width	6.2 mm
Height	80 mm
Depth	86 mm

Ambient conditions

Ambient temperature (operation)	-20 °C ... 50 °C
Ambient temperature (storage/transport)	-20 °C ... 70 °C
Degree of protection	IP20

Supply

Rated control circuit supply voltage U_s	24 V DC
Rated control supply voltage range with reference to U_s	0.8 ... 1.1
Rated control supply current I_s	14 mA
Type of protection	Reverse polarity protection
	Surge protection

Extension module - PLC-APT-PT100-IN - 2906919

Technical data

Supply

Operating voltage display	Green LED
Indication	Red LED

Input data

Input name	Analog input resistance
Sensor types (RTD) that can be used	Pt 100 (IEC 60751, $\alpha = 0,00385$)
Connection technology	2-wire
Sensor input current	~ 900 μ A
Maximum temperature coefficient	0.01 %/K
Temperature measuring range	-50 °C ... 200 °C
Maximum transmission error	1 %
Surge voltage protection	> 33 V
Input name	Analog input resistance
Sensor types (RTD) that can be used	Pt 1000 (IEC 60751, $\alpha = 0,00385$)
Connection technology	2-wire
Sensor input current	~ 900 μ A
Maximum temperature coefficient	0.01 %/K
Temperature measuring range	-50 °C ... 200 °C
Maximum transmission error	1 %
Surge voltage protection	> 33 V

Output data

Output name	Digital output
-------------	----------------

General

Operating mode	100% operating factor
Degree of protection	IP20
Mounting position	any
Assembly instructions	In rows with zero spacing

Connection data

Connection method	Push-in connection
Stripping length	8 mm
Number of connections	4
Conductor cross section solid	0.14 mm ² ... 2.5 mm ²
Conductor cross section flexible	0.14 mm ² ... 2.5 mm ²
Conductor cross section AWG	26 ... 14

Standards and Regulations

Designation	Air clearances and creepage distances
Standards/regulations	DIN EN 50178
Rated insulation voltage	50 V
Rated surge voltage	0.5 kV

Extension module - PLC-APT-PT100-IN - 2906919

Technical data

Standards and Regulations

Insulation	Basic insulation
Pollution degree	2
Overvoltage category	III
Conformance	CE-compliant
UL, USA/Canada	UL 508 Listed

Environmental Product Compliance

REACH SVHC	Lead 7439-92-1
China RoHS	Environmentally Friendly Use Period = 50
	For details about hazardous substances go to tab "Downloads", Category "Manufacturer's declaration"

Drawings

Block diagram

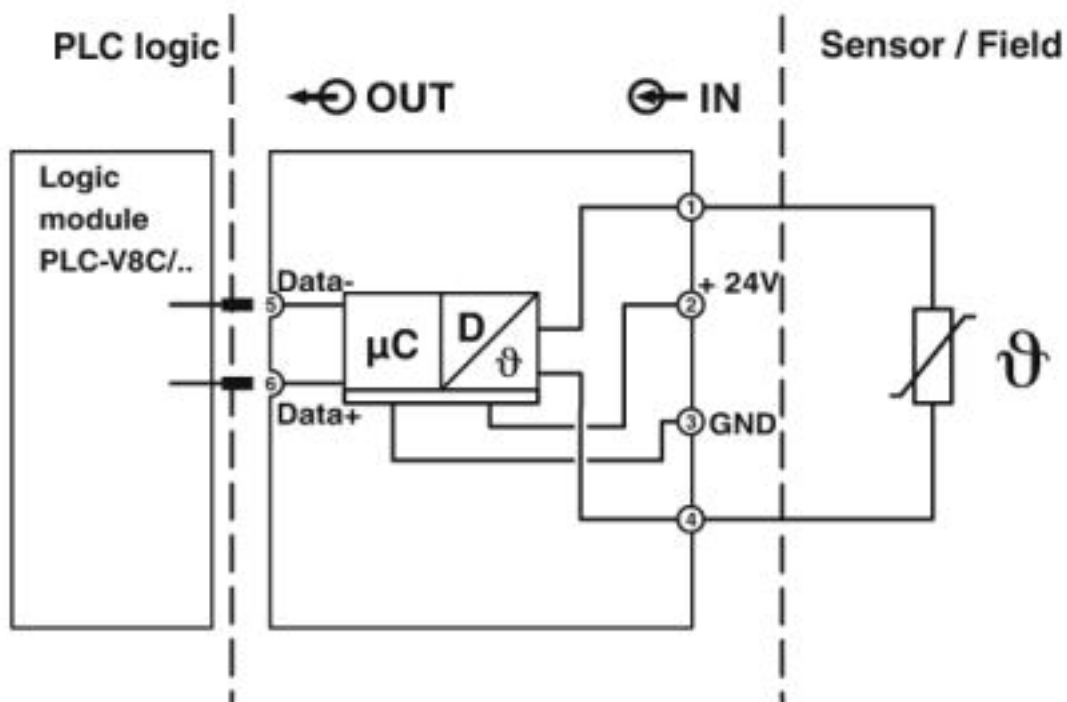

Classifications

eCl@ss

eCl@ss 5.0	27242700
eCl@ss 5.1	27242700
eCl@ss 6.0	27242200
eCl@ss 7.0	27242201

Extension module - PLC-APT-PT100-IN - 2906919

Classifications

eCl@ss

eCl@ss 8.0	27242201
eCl@ss 9.0	27242201

ETIM

ETIM 4.0	EC001420
ETIM 5.0	EC001420
ETIM 6.0	EC001420
ETIM 7.0	EC001420

Approvals

Approvals

Approvals

UL Listed / cUL Listed / EAC / cULus Listed

Ex Approvals

Approval details

UL Listed		http://database.ul.com/cgi-bin/XYV/template/LISEXT/1FRAME/index.htm	FILE E 238705
-----------	--	---	---------------

cUL Listed		http://database.ul.com/cgi-bin/XYV/template/LISEXT/1FRAME/index.htm	FILE E 238705
------------	--	---	---------------

EAC			RU*DE.*08.B.01517/19
-----	--	--	----------------------

cULus Listed			
--------------	--	--	--