



[2412PS]

AC Axial Fan Motor



Features

- Size: 60mm sq x 30mm
- Airflow: 12 - 15 m³/hr
- Noise: 28 - 29 dBA
- Weight: 140 g
- Impeller: UL94V-0 Reinforced plastic
- Venturi: Alluminium Alloy
- Lead Wire: AWG 22, Black/UL3266, CSA CL 1252
- Motor: Shaded Pole Induction Motor, Impedance protected

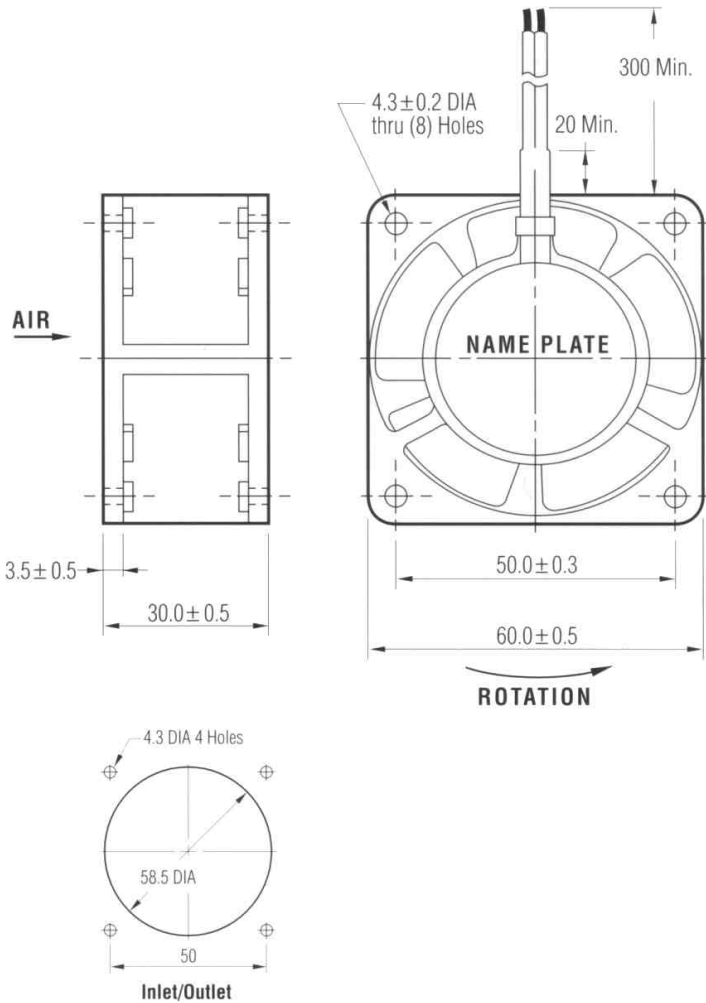

Model	Voltage (V)	Frequency (Hz)	Power (W)	Current (mA)	Speed (RPM)	Noise (dBA)	Pressure (mm H ₂ O)	Airflow	
								m ³ /hr	(CFM)
2412PS-12W-B30-A00	115	50	4,5	70	2250	28,0	1,4	12	7
		60	4,0	60	2850	29,0	1,3	15	9

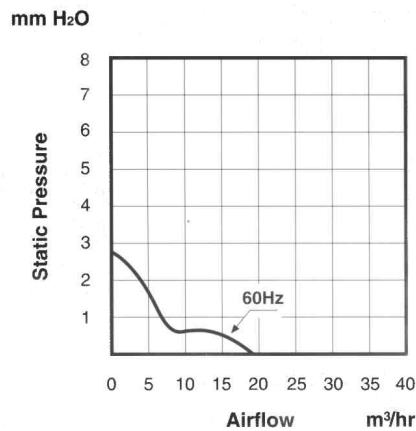
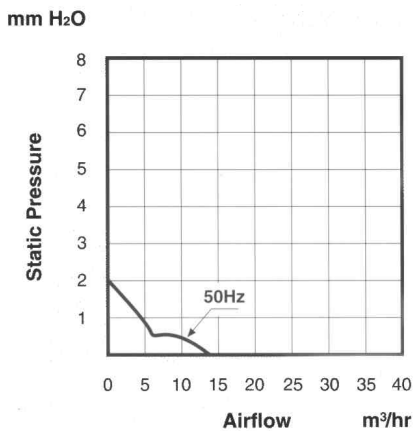

The information contained in this data sheet represents typical performance of the product, and is subject to change without notice. Product performance may be varied or enhanced to meet individual requirements. For further information please contact your local sales office



NMB (U.K.) Ltd.
NMB Minebea GmbH,
NMB Minebea Sarl,
NMB Italy Srl,
NMB Technologies Inc.,
Minebea Technologies Pte. Ltd.

1, Sterling Centre, Eastern Road, Bracknell, Berkshire RG12 2PW, England Tel (44) 1344 42 6611 Fax (44) 1344 48 5522
 Siemenstrasse 30, 63225 Langen, Germany Tel (49) 6103-913-0 Fax (49) 6103-913-220
 5 Av. Des Bosquets, 9550 Baillet en France, France Tel (33)1-34083939 Fax (33)1-34083930
 Via A Grandi 39/41, 20017 Mazzo di Rho, Milan Italy Tel (39) 2-939711 Fax (39) 2-93901154
 9730 Independence Avenue, Chatsworth, California USA Tel: (818) 341 3355 Fax: (818) 341 8207
 PSA Building, 460 Alexandra Road, #34-02, Singapore 119963 Tel (65) 278 8522 Fax (65) 444 6527

AC Axial Fan Motor

[2412PS]