

DESCRIPTION

The MP2187 is a monolithic, step-down, switch-mode dual converter with internal power MOSFETs. It can achieve up to 3A continuous output current from a 2.5V-to-5.5V input voltage with excellent load and line regulation. The output voltages of two channels are 1.1V and 1.8V respectively.

The constant-on-time control scheme provides fast transient response and eases loop stabilization. Fault condition protections include cycle-by-cycle current limiting, input voltage failure indicator and thermal shutdown.

The MP2187 is available in small 2.2mmx2.6mm QFN16 package and requires only a minimal number of readily available standard external components.

The MP2187 is ideal for a wide range of applications including high-performance DSPs, FPGAs, smart phones, portable instruments, and DVD drivers.

FEATURES

- Wide 2.5V-to-5.5V Operating Input Range
- Fixed Output Voltages: 1.1V & 1.8V
- 100% Duty Cycle in Dropout
- Up to 3A Output Current
- Low IQ: 80µA
- 60mΩ and 30mΩ Internal Power MOSFET Switches
- Input Voltage Failure Indicator
- Default 1.2MHz Switching Frequency
- EN and Power-Good for Power Sequencing
- Cycle-by-Cycle Over-Current Protection
- Auto Discharge at Power-Off
- Short-Circuit Protect with Hiccup Mode
- Stable with Low-ESR Output Ceramic Capacitors
- Available in a 2.2mm x 2.6mm QFN16 Package

APPLICATIONS

- Low Voltage I/O System Power
- Handheld/Battery-powered Systems
- Wireless/Networking Cards

All MPS parts are lead-free and adhere to the RoHS directive. For MPS green status, please visit MPS website under Products, Quality Assurance page. "MPS" and "The Future of Analog IC Technology" are registered trademarks of Monolithic Power Systems, Inc.

TYPICAL APPLICATION

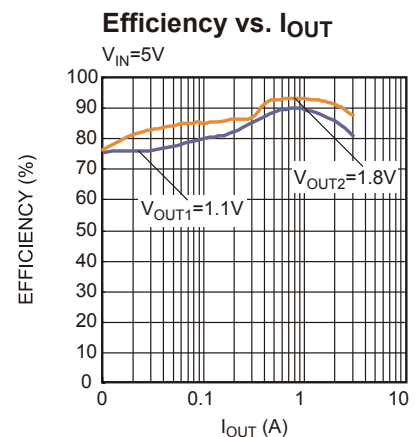
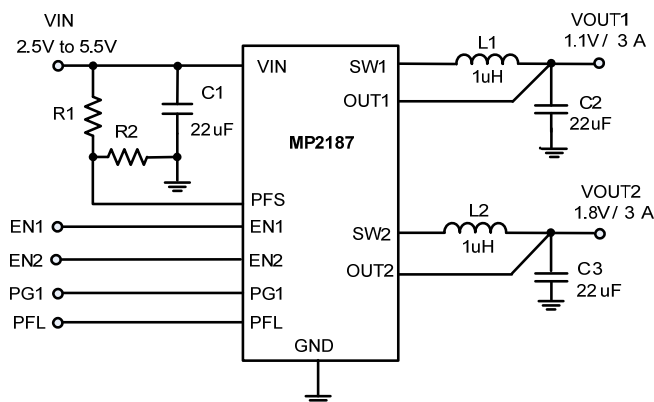

ORDERING INFORMATION

Part Number*	Package	Top Marking
MP2187GQA	QFN-16(2.2mmx2.6mm)	See Below

* For Tape & Reel, add suffix -Z (e.g. MP2187GQA-Z);

TOP MARKING

ALE
YWW
LLL

ALE: product code of MP2187GQA;
 Y: year code;
 WW: week code;
 LLL: lot number;

PACKAGE REFERENCE

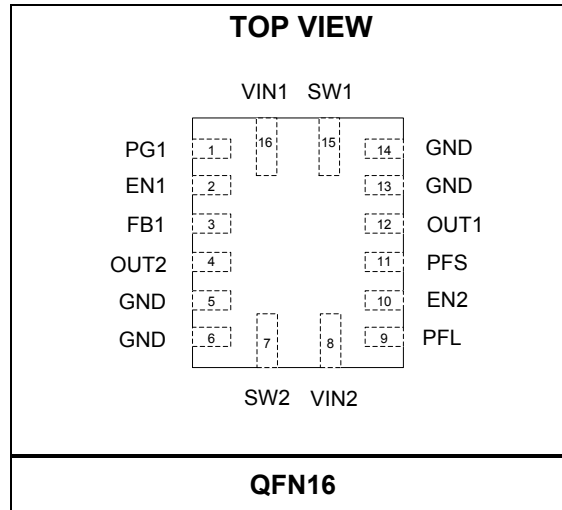

ABSOLUTE MAXIMUM RATINGS ⁽¹⁾

Supply Voltage V_{IN}	6V
V_{SW}	-0.3V (-3V for < 10ns) to 6.5V (9V<10ns)
All Other Pins	-0.3V to +6 V
Junction Temperature	150°C
Lead Temperature	260°C
Continuous Power Dissipation ($T_A = 25^\circ\text{C}$) ⁽²⁾	1.67W
Storage Temperature.....	-65°C to +150°C

Recommended Operating Conditions ⁽³⁾

Supply Voltage V_{IN}	2.5V to 5.5V
Output Voltage V_{OUT}	0.6V to $V_{IN} - 0.5V$
Operating Junction Temp. (T_J).	-40°C to +125°C

Thermal Resistance ⁽⁴⁾	θ_{JA}	θ_{JC}	
QFN-16 (2.2mm x 2.6mm).....	75.....	16...	°C/W

Notes:

- 1) Exceeding these ratings may damage the device.
- 2) The maximum allowable power dissipation is a function of the maximum junction temperature T_J (MAX), the junction-to-ambient thermal resistance θ_{JA} , and the ambient temperature T_A . The maximum allowable continuous power dissipation at any ambient temperature is calculated by P_D (MAX) = $(T_J$ (MAX) - T_A) / θ_{JA} . Exceeding the maximum allowable power dissipation will cause excessive die temperature, and the regulator will go into thermal shutdown. Internal thermal shutdown circuitry protects the device from permanent damage.
- 3) The device is not guaranteed to function outside of its operating conditions.
- 4) Measured on JESD51-7, 4-layer PCB.

ELECTRICAL CHARACTERISTICS

$V_{IN} = 5V$, $T_J = -40^{\circ}C$ to $+125^{\circ}C$, typical value is tested at $T_J = 25^{\circ}C$, unless otherwise noted.

Parameter	Symbol	Condition	Min	Typ	Max	Units
Input Voltage Range						
Input Voltage	V_{IN}		2.5		5.5	V
Supply Current						
Supply Current (Shutdown)		$V_{EN1 \text{ or } 2} = 0V$		0.1		μA
Supply Current (Quiescent)		$V_{EN} = 2V$, $V_{IN} = 3.6V$, Both channel on		80		μA
Output Voltage						
Fixed Output Voltage	V_O	1.1V rail, $T_J = 25^{\circ}C$	-1.5%	1.1	+1.5%	V/%
		1.8V rail, $T_J = 25^{\circ}C$	-1.5%	1.8	+1.5%	
Internal Feedback Voltage of 1.1V Output Channel						
Internal Feedback Voltage	V_{FB}	$2.5V \leq V_{IN} \leq 5.5V$, $T_J = 25^{\circ}C$	-1.5%	0.600	+1.5%	V/%
		$T_J = -40^{\circ}C$ to $125^{\circ}C^{(5)}$	-2%		+2%	
Power FET						
PFET Switch ON Resistance	R_{DSON_P}			60		m Ω
NFET Switch ON Resistance	R_{DSON_N}			30		m Ω
Switch Leakage		$V_{EN1 \text{ or } 2} = 0V$, $V_{IN} = 5V$ $V_{SW \ 1 \text{ or } 2} = 0V$ and $5V$, $T_J = 25^{\circ}C$		0.1	2	μA
PFET Current Limit ⁽⁶⁾			4.7	5.3		A
ON Time	T_{ON}	$V_{IN} = 5V$, $V_{OUT1} = 1.1V$		183		ns
		$V_{IN} = 5V$, $V_{OUT2} = 1.8V$		300		
Switching Frequency	F_s	$V_{IN} = 5V$, $V_{OUT1} = 1.1V$, $I_{OUT1} = 1A$ $V_{IN} = 5V$, $V_{OUT2} = 1.8V$, $I_{OUT2} = 1A$, $T_J = 25^{\circ}C$	-20%	1200	+20%	kHz
		$T_J = -40^{\circ}C$ to $125^{\circ}C^{(5)}$	-25%	1200	+25%	
Minimum OFF Time	$T_{MIN-OFF}$			50		ns
Soft Start and Soft Off						
Soft-Start Time	T_{SS-ON}	10% to 90% output voltage		0.6		ms
Soft-Stop Time	T_{SS-OFF}			1		ms
Power Good						
Power-Good Upper Trip Threshold	PG_H	FB voltage with respect to the regulation		+10		%
Power-Good Lower Trip Threshold	PG_L			-10		%
Power-Good Delay	PG_{DL}	High to low		100		μs
	PG_{DH}	Low to high		100		μs
Power-Good Sink Current Capability	V_{PG-L}	Sink 1mA			0.4	V
Power Good Logic High Voltage	V_{PG-H}	$V_{IN} = 5V$	4.9			V
Power Good Internal Pull-Up Resistor	R_{PG}			500		k Ω

ELECTRICAL CHARACTERISTICS (continued)
 $V_{IN} = 5V$, $T_J = -40^{\circ}C$ to $+125^{\circ}C$, typical value is tested at $T_J = 25^{\circ}C$, unless otherwise noted.

Parameter	Symbol	Condition	Min	Typ	Max	Units
Power Fail						
Power-Fail Threshold Rising	V_{PF}	$T_J = -40^{\circ}C$ to $125^{\circ}C$ ⁽⁵⁾	0.588	0.6	0.612	V
Power-Fail Hysteresis	V_{HYS}			12		mV
Power-Fail Delay	PF_{DL}	High to low		10		μs
	PF_{DH}	Low to high		100		μs
Power-Fail Sink Current Capability	V_{PG-L}	Sink 1mA			0.4	V
Power-Fail Logic High Voltage	V_{PG-H}	$V_{IN} = 5V$	4.9			V
Power Fail Internal Pull-Up Resistor	R_{PF}			500		k Ω
Enable						
EN Input Logic Low Voltage					0.4	V
EN Input Logic High Voltage			1.2			V
EN Input Current		$V_{EN1 \text{ or } 2} = 2V$		2		μA
		$V_{EN1 \text{ or } 2} = 0V$		0.1		μA
UVLO						
Under-Voltage Lockout Threshold Rising			2.0	2.2	2.4	V
Under-Voltage Lockout Threshold Hysteresis				150		mV
OTP						
Thermal Shutdown ⁽⁷⁾				150		$^{\circ}C$
Thermal Hysteresis ⁽⁷⁾				30		$^{\circ}C$

Notes:

- 5) Not test in production and guaranteed by over-temperature correlation
- 6) Guaranteed by engineering sample characterization.
- 7) Guaranteed by design.

TYPICAL PERFORMANCE CHARACTERISTICS

$V_{IN} = 5V$, $V_{OUT1} = 1.1V$, $V_{OUT2} = 1.8V$, $L = 1.0\mu H$, $C_{OUT} = 22\mu F$, $T_A = 25^\circ C$, unless otherwise noted.

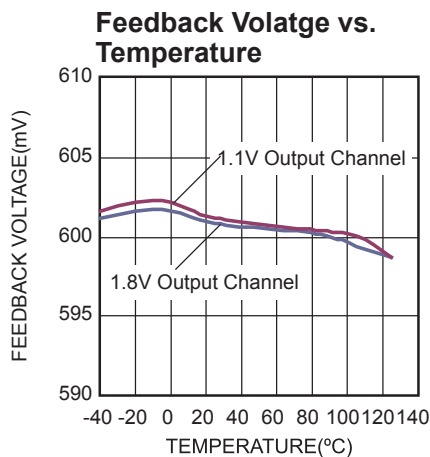
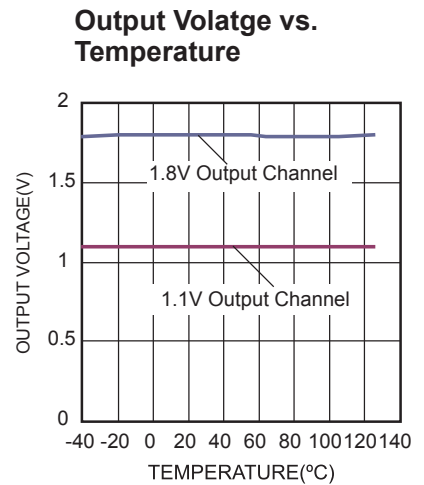
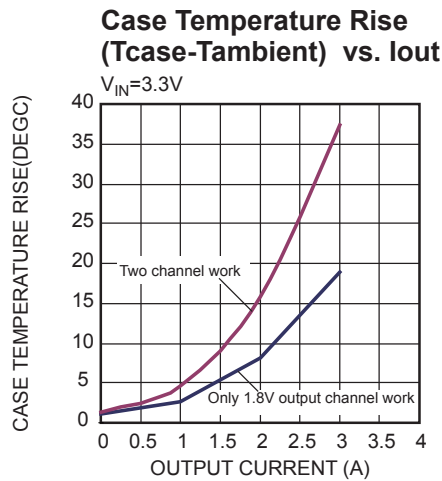
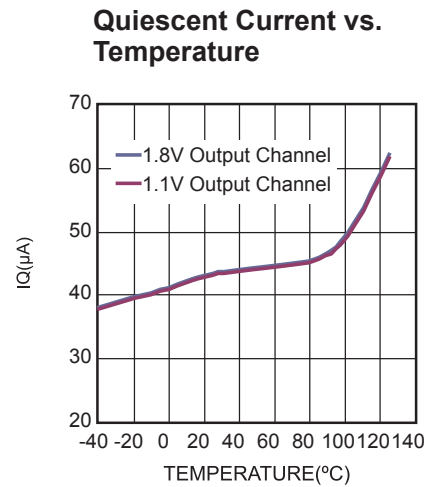
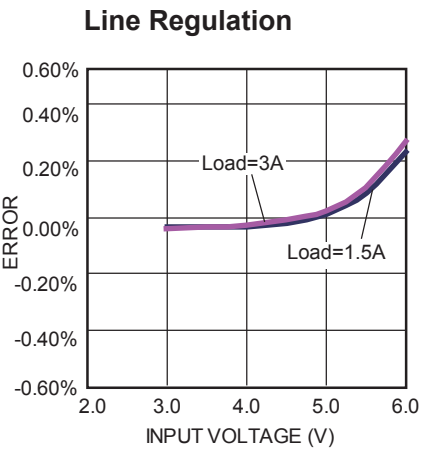
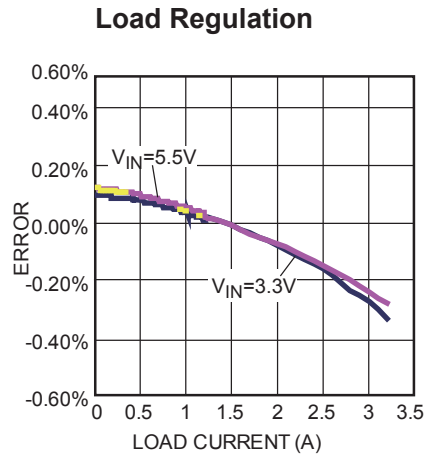
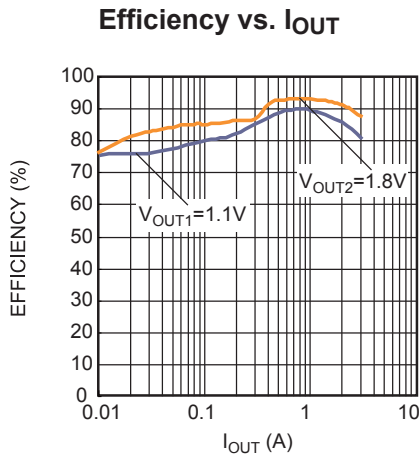

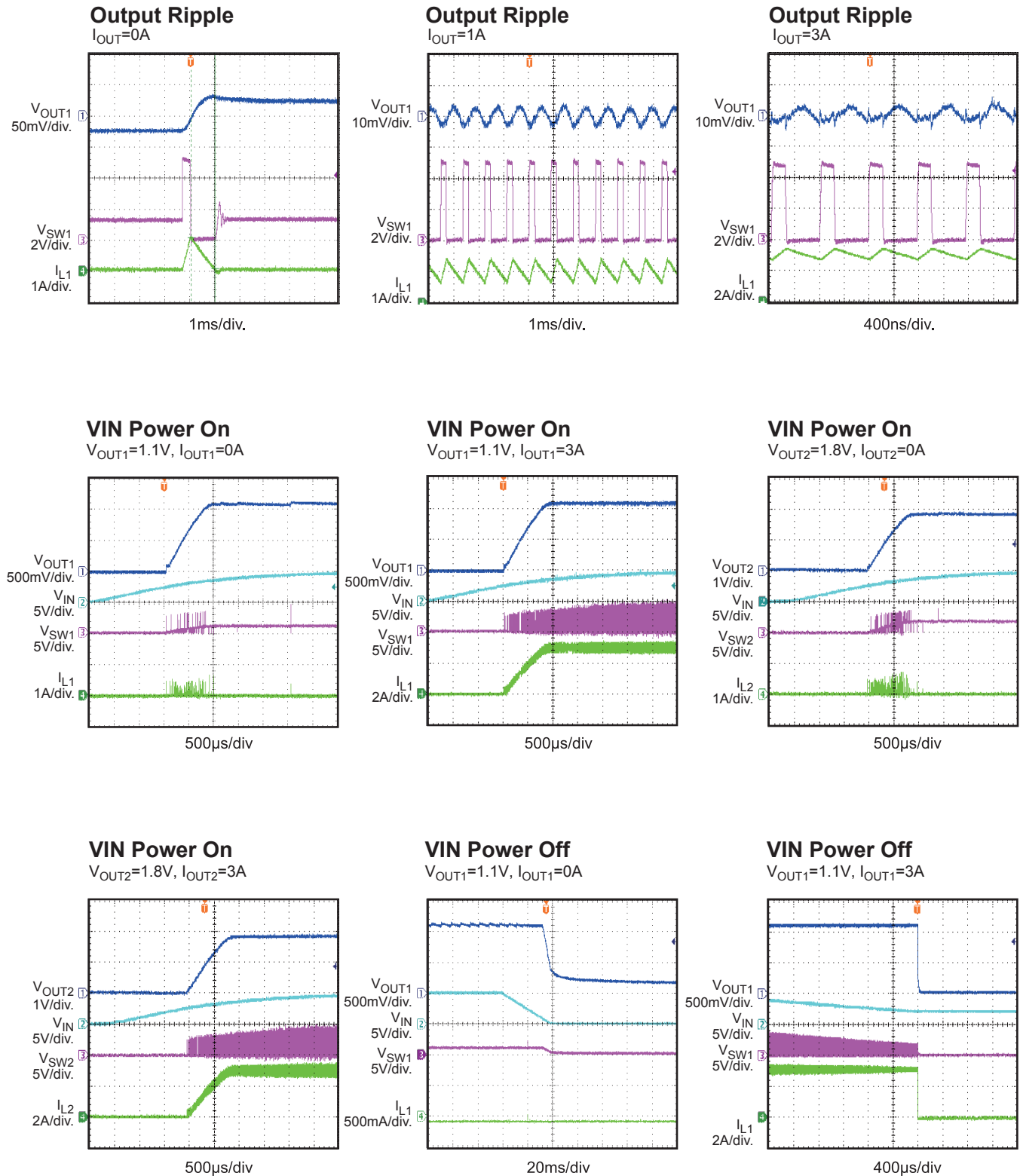
TYPICAL PERFORMANCE CHARACTERISTICS (continued)
 $V_{IN} = 5V$, $V_{OUT1} = 1.1V$, $V_{OUT2} = 1.8V$, $L = 1.0\mu H$, $C_{OUT} = 22\mu F$, $T_A = 25^\circ C$, unless otherwise noted.

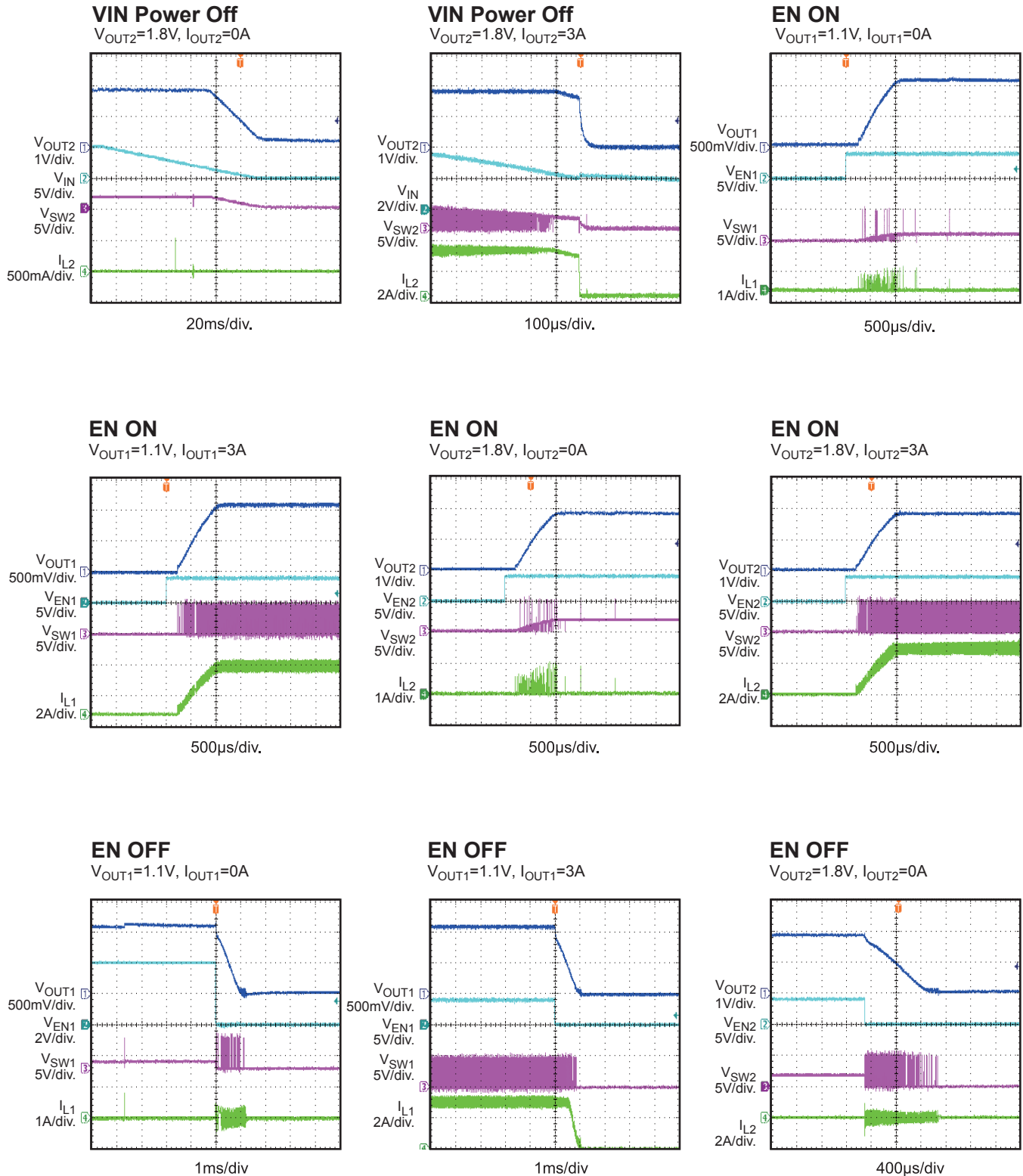
TYPICAL PERFORMANCE CHARACTERISTICS (continued)
 $V_{IN} = 5V$, $V_{OUT1} = 1.1V$, $V_{OUT2} = 1.8V$, $L = 1.0\mu H$, $C_{OUT} = 22\mu F$, $T_A = 25^\circ C$, unless otherwise noted.

TYPICAL PERFORMANCE CHARACTERISTICS (continued)

$V_{IN} = 5V$, $V_{OUT1} = 1.1V$, $V_{OUT2} = 1.8V$, $L = 1.0\mu H$, $C_{OUT} = 22\mu F$, $T_A = 25^\circ C$, unless otherwise noted.

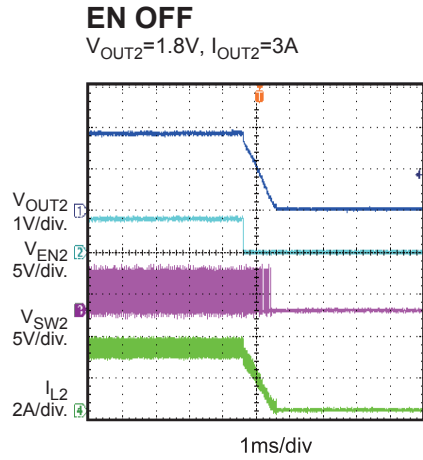

PIN FUNCTION

QFN16 Pin #	Name	Description
1	PG1	Power Good Indicator of channel 1. The output of this pin is an open drain with an internal pull up resistor to IN. PG is pulled up to VIN when the FB voltage is within 10% of the regulation level. If the FB voltage is out of that regulation range, it is LOW.
2	EN1	On/Off Control of channel 1.
3	FB1	Internal FB point of channel 1. For fixed output application, FB pin must float. For adjustable output application, it is FB pin and used to set output voltage.
4	OUT2	Output Voltage Sense pin of channel 2. For output voltage sense.
5, 6, 13, 14	GND	Power Ground.
7	SW2	Switch Output of channel 2.
8	VIN2	Supply Voltage of channel 2. The MP2187 operates from a +2.5V-to-+5.5V input.
9	PFL	Power Fails Logic. It is an open drain signal which will be pulled low When PFS voltage is lower than desired threshold.
10	EN2	On/Off Control of channel 2.
11	PFS	Power Fails sense. Using an external resistor network connect PFS from VIN to indicate the input voltage. When indicated voltage is below desired threshold, PFL is pulled down.
12	OUT1	Output Voltage Sense pin of channel 1. For output voltage sense.
15	SW1	Switch Output of channel 1.
16	VIN1	Supply Voltage of channel 1. The MP2187 operates from a +2.5V-to-+5.5V input.

FUNCTIONAL BLOCK DIAGRAM

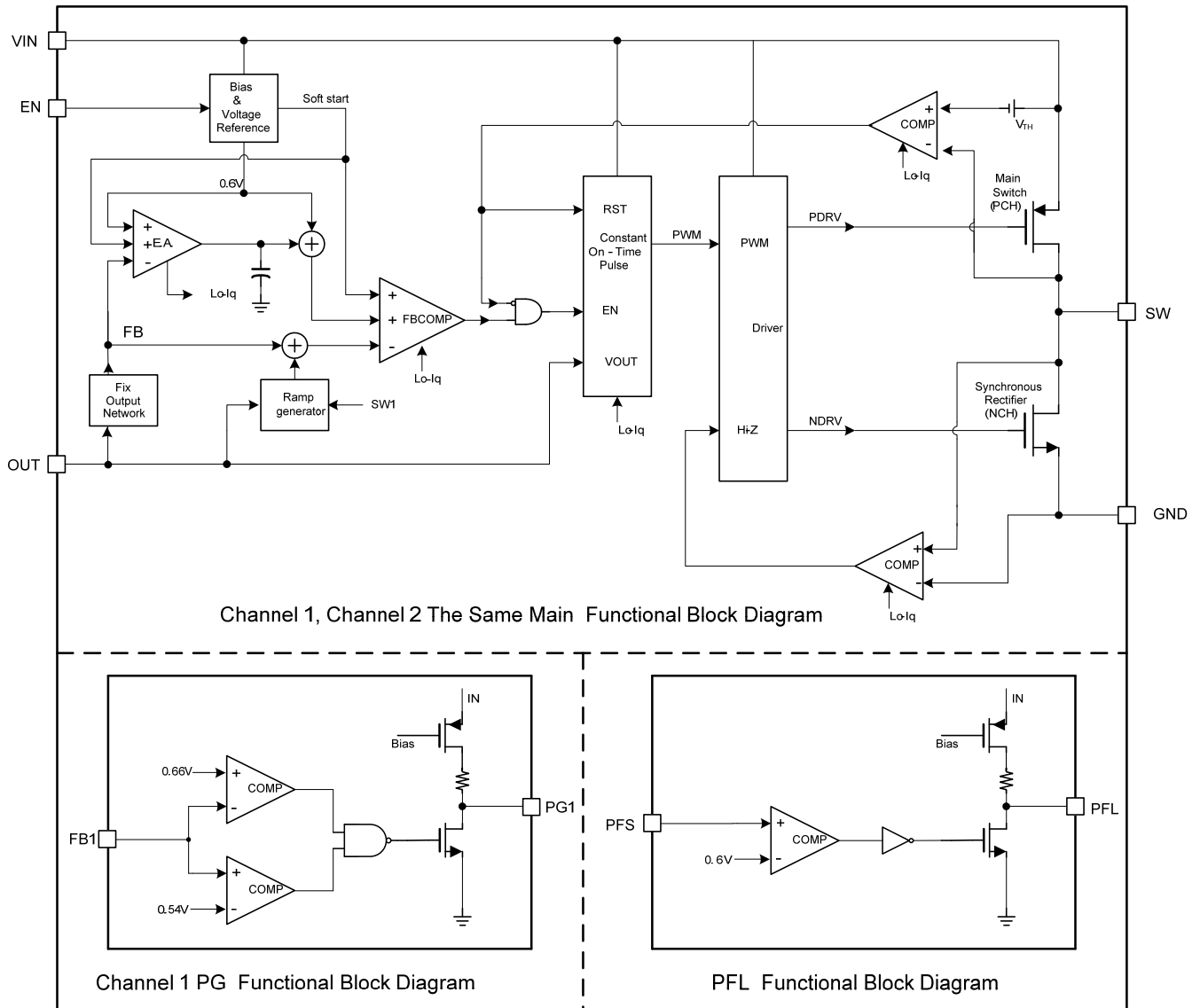

Figure 1: Functional Block Diagram

OPERATION

The MP2187 uses constant on-time control with input voltage feed-forward to stabilize the switching frequency over its full input range. At light load, the MP2187 employs proprietary control over the low-side MOSFET (LS-FET) and inductor current to eliminate ringing on switching node and improve efficiency. The output voltages are fixed. The output voltages of two channels are 1.1V and 1.8V respectively.

Constant-On-Time Control

When compared to fixed-frequency PWM control, constant-on-time control offers advantages including simpler control loop and faster transient response. By using input voltage feed-forward, the MP2187 maintains a nearly constant switching frequency across the entire input and output voltage range. The on-time of the switching pulse can be estimated as:

$$t_{ON} = \frac{V_{OUT}}{V_{IN}} \cdot 0.833\mu s$$

To prevent inductor current runaway during the load transient, the MP2187 has a fixed minimum off time of 50ns. However, this minimum off time limit does not affect the operation of the MP2187 in steady state in any way.

Light-Load Operation

Under light-load conditions, the MP2187 uses a proprietary control scheme to save power and improve efficiency: it gradually ramps down the LS-FET current to its minimum instead of turning off the LS-FET immediately when the inductor current starts to reverse. The gradual current drop avoids ringing at the switching node that always occurs in discontinuous conduction mode (DCM) operation.

There is a zero current cross detect circuit (ZCD) to judge if the inductor current starts to reverse. When the inductor current touch ZCD threshold, the low side switch will start to be turned off.

The DCM mode happens only after low side switch turned off by ZCD circuit. Considering the ZCD circuit propagation time, the typical

delay is 30ns. It means the inductor current still fall after the ZCD is trigger during this delay. If the inductor current falling slew rate is fast (Output voltage is high or close to input Voltage), the low side MOSFET is turned off at the moment inductor current may be negative. This phenomena will cause PM2187 cannot enter DCM operation. If the DCM mode is required, the off time of low side MOSFET in CCM should be longer than 60ns. It means the maximum duty is 92% to guarantee DCM mode at light load. For example, V_{in} is 3.4V and V_o is 3.3V, the off time in CCM is 24.5ns. It is difficult to enter DCM at light load. And using smaller inductor can improve it and make it enter DCM easily.

Enable

When the input voltage exceeds the under-voltage lockout (UVLO) threshold—typically 2.2V—the MP2187 can be enabled by pulling the EN pin higher than 1.2V. Leaving EN pin floating or grounded will disable the MP2187. There is an internal 1M Ω resistor from the EN pin to ground.

Soft-Start/Stop

MP2187 has a built-in soft-start that ramps up the output voltage at a constant slew rate that avoids overshooting at startup. The soft-start time is typically about 0.6ms. When disabled, the MP2187 ramps down the internal reference voltage to allow the load to linearly discharge the output.

Power GOOD Indicator

MP2187 has an open drain with a 500k Ω pull-up resistor pin for power good (PG) indication, and the power good indication is only for channel 1. When the FB pin is within $\pm 10\%$ of the regulatory voltage (0.6V), the PG pin is pulled up to V_{IN} by the internal resistor. If the FB pin voltage is outside the $\pm 10\%$ window, the PG pin is pulled to ground by an internal MOSFET. The MOSFET has a maximum R_{dson} of less than 100 Ω .

Input Voltage Failure Indicator

MP2187 has input voltage failure indicator function. There is an external resistor network connect PFS (power fail sense) from VIN, when PFS is lower than Power-Fail Falling threshold (typically 0.588V), the PFL will be pulled to ground by an internal MOSFET.

Current limit

The MP2187 has a 5.3A current limit for the high side switch (HS-FET). When the HS-FET hits its current limit, MP2187 enters hiccup mode until the current drops to prevent the

inductor current from rising and possibly damaging the components.

Short Circuit and Recovery

The MP2187 also enters short-circuit protection (SCP) mode when it hits the current limit, and tries to recover from the short circuit by entering hiccup mode. In SCP, the MP2187 disables the output power stage, discharges a soft-start capacitor, and then enacts a soft-start procedure. If the short-circuit condition still holds after soft-start ends, the MP2187 repeats this operation until the short circuit ceases and output rises back to regulation level.

APPLICATION INFORMATION

COMPONENT SELECTION

Selecting the Channel 1 Output Voltage

The 1.1V output voltage can be changed with external feedback resistors. The feedback resistor R1 and R2 cannot be too large considering the internal divider resistors. Choose R1 +R2 <20kΩ:

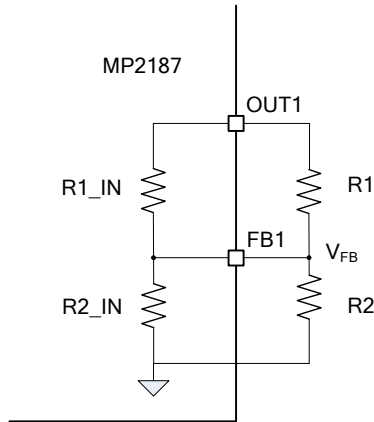

Using below formulas to set the new output voltages:

$$R_1 = \frac{V_O - V_{FB}}{V_{FB}} \times R_2$$

Where VFB=0.6V.

Table 1 lists the recommended resistors values for common output voltage.

Table 1: Resistor Values for Common Channel 1 Output Voltages

V _{O1} (V)	R ₁ (kΩ)	R ₂ (kΩ)
1.2	3	3
1.5	4.7	3
1.8	6.2	3
2.5	9.53	3
3.3	13.7	3

Selecting the Input Voltage Failure Threshold

MP2187 can set input voltage failure threshold with external resistors network. Below is the input voltage failure circuit:

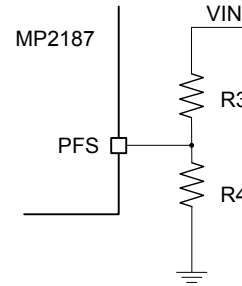

R3 is given by:

$$R_3 = \frac{V_{IN} - 0.6}{0.6} \times R_4$$

The divider resistors R3 and R4 cannot be too small considering the leakage from VIN to GND. Choose R3+R4>1MΩ.

Selecting the Inductor

A 0.82μH to 4.7μH inductor is recommended for most applications. For highest efficiency, choose an inductor with a DC resistance less than 15mΩ. For most designs, the inductance value can be derived from the following equation.

$$L_1 = \frac{V_{OUT} \times (V_{IN} - V_{OUT})}{V_{IN} \times \Delta I_L \times f_{OSC}}$$

Where ΔI_L is the inductor ripple current.

Choose an inductor current to be approximately 30% of the maximum load current. The maximum inductor peak current is:

$$I_{L(MAX)} = I_{LOAD} + \frac{\Delta I_L}{2}$$

Selecting the Input Capacitor

The input current to the step-down converter is discontinuous, and requires a capacitor to supply the AC current to the step-down converter while maintaining the DC input voltage. Use low-ESR capacitors for the best performance. Ceramic capacitors with X5R or X7R dielectrics are highly recommended because of their low ESR values and small temperature coefficients. For most applications, a 10μF capacitor is sufficient. For higher output voltage, use 47μF to improve system stability.

Since the input capacitor absorbs the input switching current it requires an adequate ripple current rating. The RMS current in the input capacitor can be estimated by:

$$I_{C1} = I_{LOAD} \times \sqrt{\frac{V_{OUT}}{V_{IN}} \times \left(1 - \frac{V_{OUT}}{V_{IN}}\right)}$$

The worse case condition occurs at $V_{IN} = 2V_{OUT}$, where:

$$I_{C1} = \frac{I_{LOAD}}{2}$$

For simplification, choose an input capacitor whose RMS current rating greater than half of the maximum load current.

The input capacitor can be electrolytic, tantalum or ceramic. When using electrolytic or tantalum capacitors, use a small high-quality ceramic capacitor (0.1 μ F), placed as close to the IC as possible. When using ceramic capacitors, make sure that they have enough capacitance to prevent excessive voltage ripple at input. The input voltage ripple caused by capacitance can be estimated by:

$$\Delta V_{IN} = \frac{I_{LOAD}}{f_s \times C1} \times \frac{V_{OUT}}{V_{IN}} \times \left(1 - \frac{V_{OUT}}{V_{IN}}\right)$$

Selecting the Output Capacitor

The output capacitor (C2) maintains the output DC voltage. Use ceramic capacitors. Low-ESR capacitors keep the output voltage ripple low. The output voltage ripple can be estimated by:

$$\Delta V_{OUT} = \frac{V_{OUT}}{f_s \times L_1} \times \left(1 - \frac{V_{OUT}}{V_{IN}}\right) \times \left(R_{ESR} + \frac{1}{8 \times f_s \times C2}\right)$$

Where L_1 is the inductor value and R_{ESR} is the equivalent series resistance of the output capacitor.

Using ceramic capacitors, the impedance at the switching frequency is dominated by the capacitance. The output voltage ripple is mainly caused by the capacitance. For simplification, the output voltage ripple can be estimated by:

$$\Delta V_{OUT} = \frac{V_{OUT}}{8 \times f_s^2 \times L_1 \times C2} \times \left(1 - \frac{V_{OUT}}{V_{IN}}\right)$$

For tantalum or electrolytic capacitors, the ESR dominates the impedance at the switching

frequency. For simplification, the output ripple can be approximated as:

$$\Delta V_{OUT} = \frac{V_{OUT}}{f_s \times L_1} \times \left(1 - \frac{V_{OUT}}{V_{IN}}\right) \times R_{ESR}$$

The characteristics of the output capacitor also affect the stability of the regulation system.

PCB Recommendation of MP2187

Proper layout of the switching power supplies is very important, and sometimes critical for proper operation. For high-frequency switching converters, poor layout could lead to poor line or load regulation and stability issues.

The high current paths (GND, IN, and SW) should be placed very close to the device using short, direct, and wide traces. The input capacitor needs to be as close as possible to the IN and GND pins. The external feedback resistors should be placed next to the FB pin. Keep the switching node SW short and away from the feedback network.

For MP2187 PCB layout, there are two recommended layouts for selecting. Figure 2 (refer to schematic figure 4) shows symmetric PCB layout. If the layout is space limited, and has to be asymmetric, a ferrite bead (The Impedance should >220m Ω @100MHz) is suggested to separate the two input of each channel. Figure 3 (refer to schematic figure 5) shows asymmetric PCB layout.

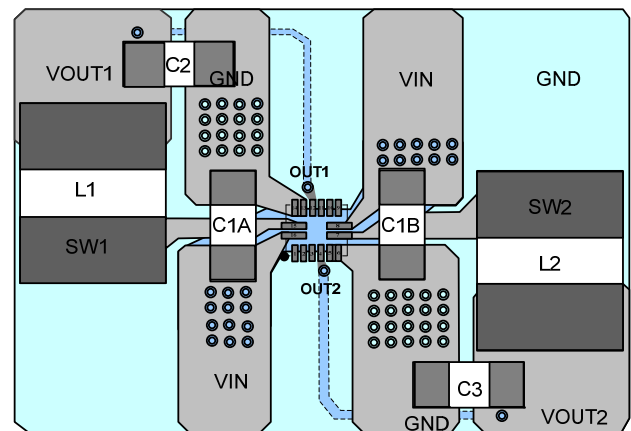

Figure 2: Symmetric PCB Layout

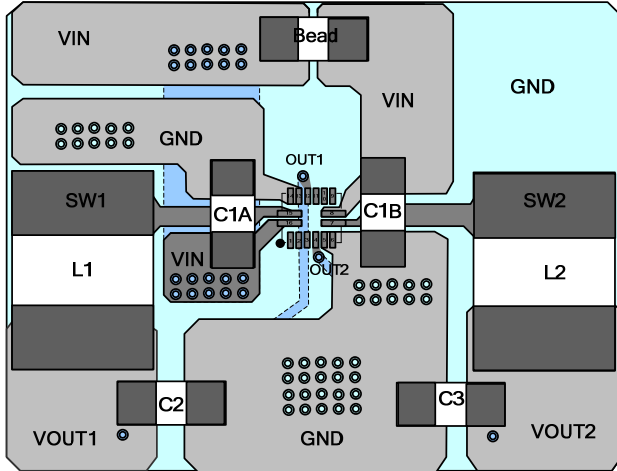

Figure 3: Asymmetric PCB Layout

Design Example

Below is a design example following the application guidelines for the specifications:

Table 2: Design Example

V_{IN}	5V
V_{OUT1}	1.1V
V_{OUT2}	1.8V
$I_{OUT1}=I_{OUT2}$	3A

The detailed application schematic is shown in Figure 4 and Figure 5. The typical performance and circuit waveforms have been shown in the Typical Performance Characteristics section. For more device applications, please refer to the related Evaluation Board Datasheets.

TYPICAL APPLICATION CIRCUITS

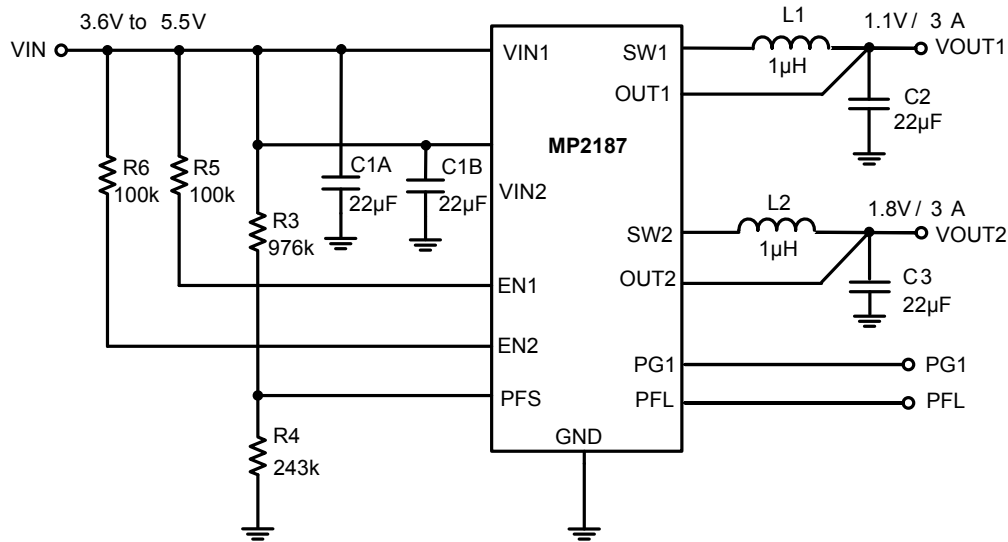

Figure4: MP2187 Typical Application Circuit for Symmetric PCB Layout

Note: Low V_{IN} application may need more input capacitors

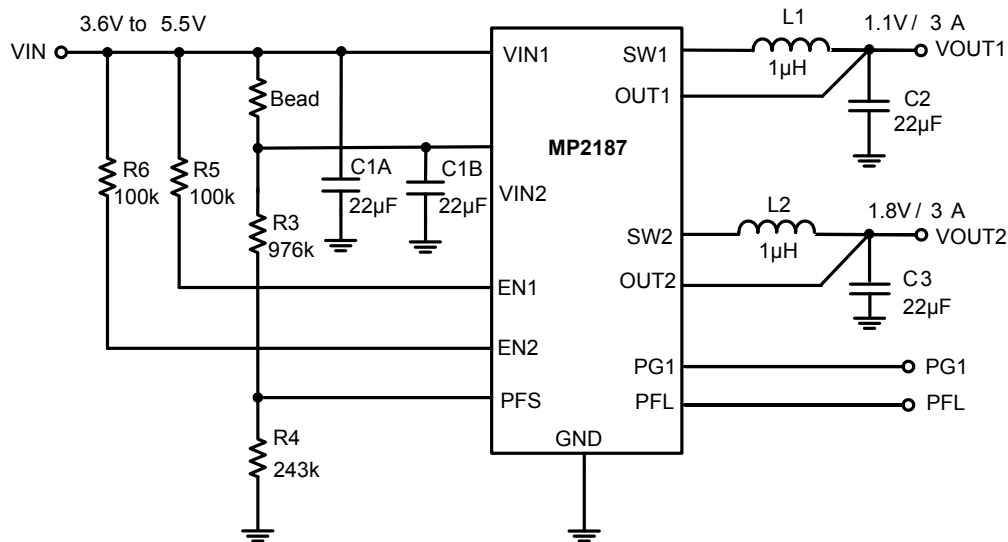
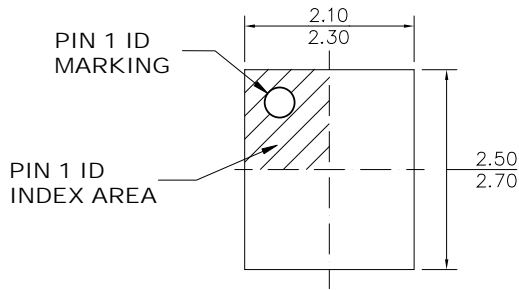
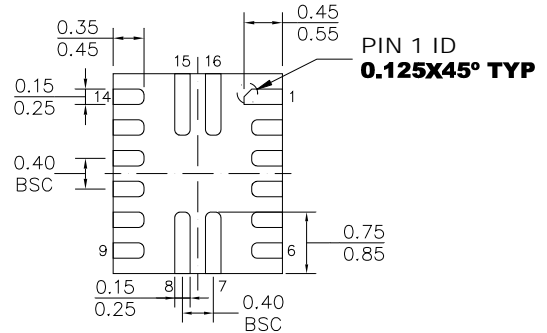
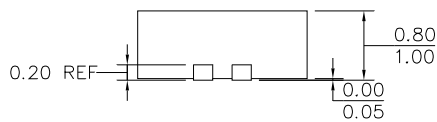
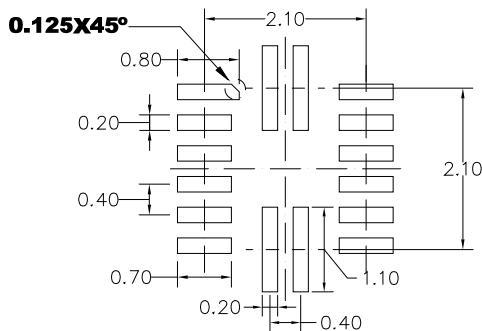

Figure 5: MP2187 Typical Application Circuit for Asymmetric PCB Layout

Note: Low V_{IN} application may need more input capacitors

PACKAGE INFORMATION
QFN-16 (2.2mm x 2.6mm)

TOP VIEW

BOTTOM VIEW

SIDE VIEW

NOTE:

- 1) ALL DIMENSIONS ARE IN MILLIMETERS.
- 2) EXPOSED PADDLE SIZE DOES NOT INCLUDE MOLD FLASH.
- 3) LEAD COPLANARITY SHALL BE 0.10 MILLIMETERS MAX.
- 4) JEDEC REFERENCE IS MO-220.
- 5) DRAWING IS NOT TO SCALE.

NOTICE: The information in this document is subject to change without notice. Please contact MPS for current specifications. Users should warrant and guarantee that third party Intellectual Property rights are not infringed upon when integrating MPS products into any application. MPS will not assume any legal responsibility for any said applications.