

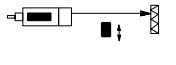



Sensing	Supply Voltage	Output
 30 cm, 1 m	12 to 24 VDC	 80 mA, 24 VDC with 1.5 to 4 mA constant current source; 100 mA, 24 VDC

Transparent Object Detection Sensor

E3S-R





Transparent Object Sensor with Built-in DC Amplifier

- Detects clear glass or plastic bottles, and transparent films with simple setup
- Fast, 1 ms maximum response time
- Choose PNP or NPN output models
- Light-on/dark-on operation, wire selectable
- Vertical and horizontal mounting styles
- Ready-to-use: prewired with 2 m (6.56 ft) cable, includes mounting bracket







Ordering Information

■ PLASTIC-HOUSING COMPACT MODELS

Connection	Appearance	Sensing method	Sensing distance	Light source color	Operating modes	Part Number		Recommended application (see note 1)	
						NPN	PNP	Flat object	Cylindrical object
Pre-wired	 Horizontal	Retro-reflective	10 to 30 cm	Infrared	Light-ON Dark-ON (selectable)	E3S-R12	E3S-R32	Ideal	Ideal
			0.1 to 1 m	Red		E3S-R11	E3S-R31	Ideal	---
	 Vertical		10 to 30 cm	Infrared		E3S-R62	E3S-R82	Ideal	Ideal
			0.1 to 1 m	Red		E3S-R61	E3S-R81	Ideal	---
Plug-in connector (see note 2)	 Horizontal	Retro-reflective	10 to 30 cm	Infrared	Light-ON Dark-ON (selectable)	E3S-R17	E3S-R37	Ideal	Ideal
			0.1 to 1 m	Red		E3S-R16	E3S-R36	Ideal	---
	 Vertical		10 to 30 cm	Infrared		E3S-R67	E3S-R87	Ideal	Ideal
			0.1 to 1 m	Red		E3S-R66	E3S-R86	Ideal	---

- Note:
1. The E3S-R may not easily sense some glass wafers (due to their materials) or plastic bottles (due to their shapes). Before using the E3S-R for the sensing of glass wafers or plastic bottles, be sure to use test examples of the glass wafers or plastic bottles to check if the E3S-R senses the examples easily.
 2. Refer to connector information provided later in this data sheet.
 3. Consult your OMRON representative before using the product under conditions not described in the manual or applying the product to nuclear control systems, and other systems, machines, and equipment that may have a serious influence on lives and property. Make sure that the ratings and performance characteristics of the product are correct for the systems, machines, and equipment and provide double safety mechanisms.

■ METAL-HOUSING MODELS

Method of detection		Retroreflective			
Sensing distance		30 cm (11.81 in)		1 m (3.28 ft)	
Mounting style		Horizontal 	Vertical 	Horizontal 	Vertical 
Part Number	NPN Output	E3S-RS30E4-30	E3S-RS30E42-30	E3S-R1E4	E3S-R1E42
	PNP Output	E3S-RS30B4-30	E3S-RS30B42-30	E3S-R1B4	E3S-R1B42

Application Examples

■ TYPICAL APPLICATIONS

Sensing of Glass Wafers and LCD Glass Circuit Bottles

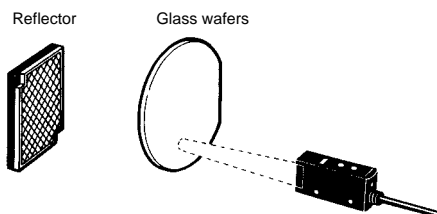

Sensing of Plastic Bottles and Other Transparent Bottles

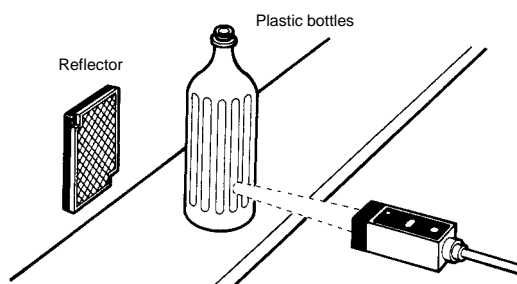

Detecting Clear Glass Bottles on a Conveyor

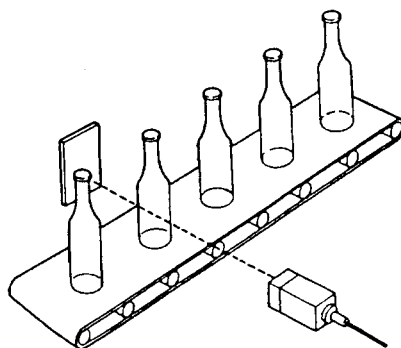

Detecting Clear Plastic Film

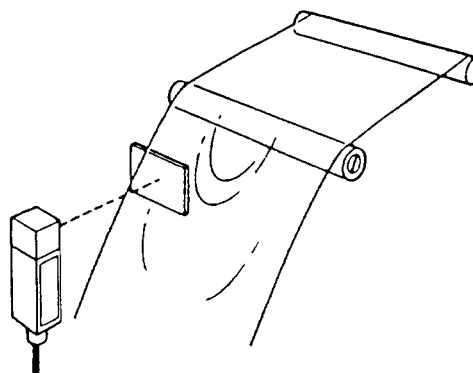

Specifications

Part Number	E3S-R12/-R62/-R17/ -R67/-R32/-R82/-R37/ -R87	E3S-R11/-R61/-R16/ -R66/-R31/-R81/-R36/ -R86	E3S-RS30□4/ -RS30□42	E3S-R1□4/-R1□42
LED for emitter	Infrared LED	Red LED	Infrared LED	
Indicator	Light indicator (red), excess gain indicator (green)		Light indicator (red)	Light indicator (red), stability indicator (green)
Sensitivity adjustment	Two-turn adjustor with an indicator		One-turn adjustor	
Connection method	See note		Pre-wired	
Materials	Case	Polybutylene terephthalate		Zinc die-cast
	Lens	Denatured polyallylate		Polycarbonate

Note: The E3S-R11/-R12/-R61/-R62/-R31/-R32/-R81/-R82 each have a pre-wired cord.
The E3S-R16/-R17/-R66/-R67/-R36/-R37/-R86/-R87 each have a plug-in connector.

■ RATINGS/CHARACTERISTICS

Item	E3S-R12/-R62/ -R17/-R67	E3S-R11/-R61/ -R16/-R66	E3S-R32/-R82/ -R37/-R87	E3S-R31/-R81/ -R36/-R86	E3S-RS30□4/ -RS30□42	E3S-R1□4/ -R1□42
Power supply voltage	10 to 30 VDC; ripple: 10% max.				12 to 24 VDC±10%; ripple: 10% max.	
Current consumption	30 mA max.				40 mA max.	
Sensing distance	10 to 30 cm	0.1 to 1 m	10 to 30 cm	0.1 to 1 m	30 cm	1 m
Sensing method	Retroreflective	Retroreflective with polarized function	Retroreflective	Retroreflective with polarized function	Retroreflective	
Standard sensing object	0.7-mm-thick LCD glass boards; 10-mm-dia., 1.0-mm-thick, 30-mm-long cylindrical glass objects	0.7-mm-thick LCD glass boards	0.7-mm-thick LCD glass boards; 10-mm-dia., 1.0-mm-thick, 30-mm-long cylindrical glass objects	0.7-mm-thick LCD glass boards	10-mm-dia., 1.0-mm-thick, 30-mm-long cylindrical glass objects	
Response time	1 ms max. for both operation and release					
Control output (no-contact output)	NPN open collector, 30 VDC, 100 mA max.		PNP open collector, 30 VDC, 100 mA max.		Output current: 1.5 to 4 mA at 24 VDC; NPN output (with suffix -E): 80 mA PNP output (with suffix -B): 100 mA	
Ambient illumination	Incandescent lamp	5,000 lx max.			Illumination on optical spot: 3,000 lx max.	
	Sunlight	10,000 lx max.			Illumination on optical spot: 10,000 lx max.	
Ambient temperature	Operating: 0°C to 40°C (32°F to 104°F) with no icing					Operating: -25°C to 55°C (-13°F to 131°F) with no icing
Ambient humidity	Operating: 35% to 85%					
Insulation resistance	20 MΩ min. (at 500 VDC)					
Dielectric strength	1,000 VAC, 50/60 Hz for 1 min					
Vibration resistance	Destruction: 10 to 55 Hz, 1.5-mm double amplitude for 2 h each in X, Y, and Z directions					
Shock resistance	Destruction: 500 m/s ² (approx. 50G) for 3 times each in X, Y, and Z directions					
Protection	Load short-circuit protection, reverse polarity protection, mutual interference prevention				Load short-circuit protection, mutual interference prevention	
Enclosure rating	IEC: IP67					

- Note: 1. The above sensing distances are possible when the E39-R1 Reflector is used. The E39-R1 Reflector is provided with the E3S-R.
2. Even though the excess gain indicator of the E3S-R is dimly lit during sensitivity adjustment of the E3S-R, the E3S-R will provide stable operation if the ambient temperature does not rise or fall by more than 5°C while the E3S-R is operating.

■ CHARACTERISTIC DATA (REFERENCE VALUES)

Light Level Change Rates with Various Transparent Objects (See Note 1)

The following are the permeation rates of a various transparent objects on condition that a permeation rate of 100 means that there is no object within the sensing distance of the E3S-R. The permeation rate of any type of object sensed by the E3S-R must be as low as possible for the stable sensing of the object. Before using the E3S-R to sense objects, use samples of the objects to check if the E3S-R can sense the samples easily.

Sensing Object		E3S-R12/-R62/-R17/ -R67/-R32/-R82/ -R37/-R87	E3S-R11/-R61/-R16/ -R66/-R31/-R81/ -R36/-R86	E3S-RS30□□	E3S-R1□□
		Center	Center	Center	Center
Cylindrical glass object	10-dia. x 30, t = 1.0	27	---	20	33
	15-dia. x 30, t = 1.25	27	---	20	13
	20-dia. x 30, t = 1.7	22	---	28	13
	30-dia. x 30, t = 1.9	41	---	43	23
	100-dia. x 30, t = 2.5	58	---	55	50
	200-dia. x 30, t = 5.0	55	---	58	58
Glass plate	50 x 50, t = 0.5	82	91.5	78	---
	50 x 50, t = 1	74	82.5	70	75
	50 x 50, t = 2	73	81	70	75
	50 x 50, t = 3	62	69	58	65
	50 x 50, t = 5	53	59	50	55
	50 x 50, t = 10	38	42	35	40
Liquid crystal glass	t = 0.5 (permeability of 98%) (see note 2)	86	96	---	---
	t = 0.7 (permeability of 95%) (see note 2)	81	90	---	---
	t = 1.1 (permeability of 91%) (see note 2)	75	83	---	---
Operating range		95 max.	95 max.	90 max.	80 max.
Stable operating range		90 max.	90 max.	70 max.	60 max.

Note: 1. The sensing distance of each model was set to the rated sensing distance.
2. The permeability values were checked with light with a wavelength of 700 μm.

Engineering Data

■ REFLECTOR OPERATING RANGE (TYPICAL)

E3S-R11/-R61/-R16/-R66/-R31/-R81/
-R36/-R86

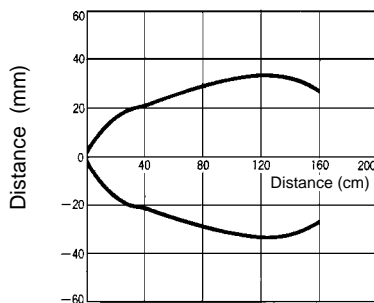

E3S-R12/-R62/-R17/-R67/-R32/-R82/
-R37/-R87

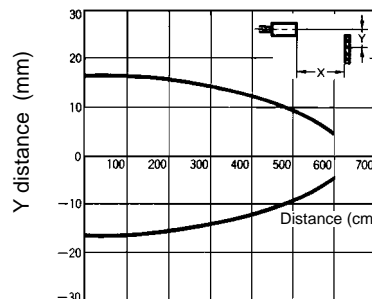

■ EXCESS GAIN VS. SET DISTANCE
(TYPICAL)

E3S-R11/-R61/-R16/-R66/-R31/-R81/-R36/-R86
with E39-R1

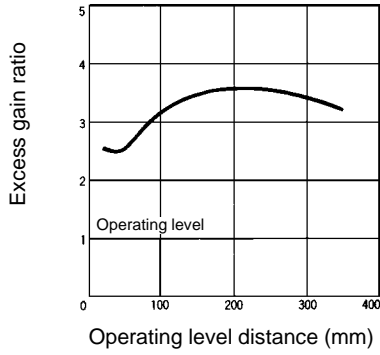

E3S-R12/-R62/-R17/-R67/-R32/-R82/
-R37/-R87

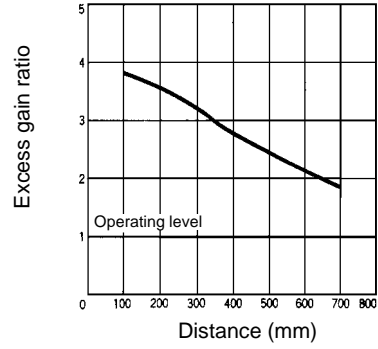

Operation

■ OUTPUT CIRCUITS

E3S-R11/-R12/-R61/-R62/-R16/-R17/-R66/-R67

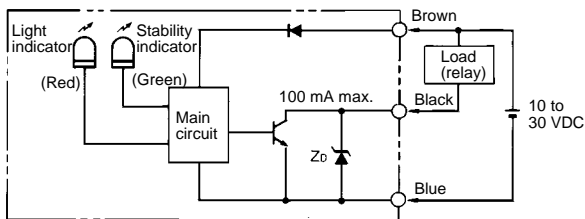

E3S-R31/-R32/-R81/-R82/-R36/-R37/-R86/-R87

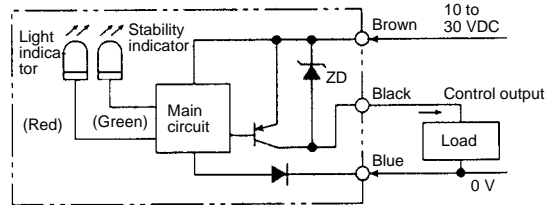

E3S-RS30□4/-RS30□42/-R1□4/-R1□42

Color of Code	Polarity of Power Supply	Output Configuration	Output Circuit
Brown (see note 1)	+	Light-ON	
Blue (see note 1)	0 V		
Brown (see note 1)	0 V	Dark-ON	
Blue (see note 1)	+		

- Note:
- Reverse the polarity of the power supply to change the output mode.
 - The E3S-RS30□ and E3S-RS30□42 do not have a stability indicator.
 - This load is needed when voltage output to connect a transistor circuit is required.

■ TIMING CHARTS

E3S-R11/-R12/-R61/-R62/-R16/-R17/-R66/-R67/-R31/-R32/-R81/-R82/-R36/-R37/-R86/-R87

Output Transistor	Timing Charts
ON when light is received	<p>Light received Light not received</p> <p>Light indicator (red) ON OFF</p> <p>Output transistor ON OFF</p> <p>Load (relay) Operate Release (Between brown and black)</p>
ON when light is not received	<p>Light received Light not received</p> <p>Light indicator (Orange) ON OFF</p> <p>Output transistor ON OFF</p> <p>Load (relay) Operate Release (Between brown and black)</p>

E3S-RS30□4/-RS30□42/-R1E□/-R1□42

Color of Code	Polarity of Power Supply	Output Transistor	Timing Charts
Brown (see note)	+	ON when light is received.	<p>Light received Light not received</p> <p>Light indicator (red) ON OFF</p> <p>Output transistor ON OFF</p> <p>Load (relay) Operate Release (Between brown and black)</p> <p>Output voltage (logic, etc.) H L (Between blue and black)</p>
Blue (see note)	0 V		
Brown (see note)	0 V	ON when light is not received.	<p>Light received Light not received</p> <p>Light indicator (red) ON OFF</p> <p>Output transistor ON OFF</p> <p>Load (relay) Operate Release (Between blue and black)</p> <p>Output voltage (logic, etc.) H L (Between brown and black)</p>
Blue (see note)	+		

Note: Reverse the polarity of the power supply to change the output mode of the E3S-R.

Dimensions

Unit: mm (inch)

E3S-R11/-R12/-R31/-R32

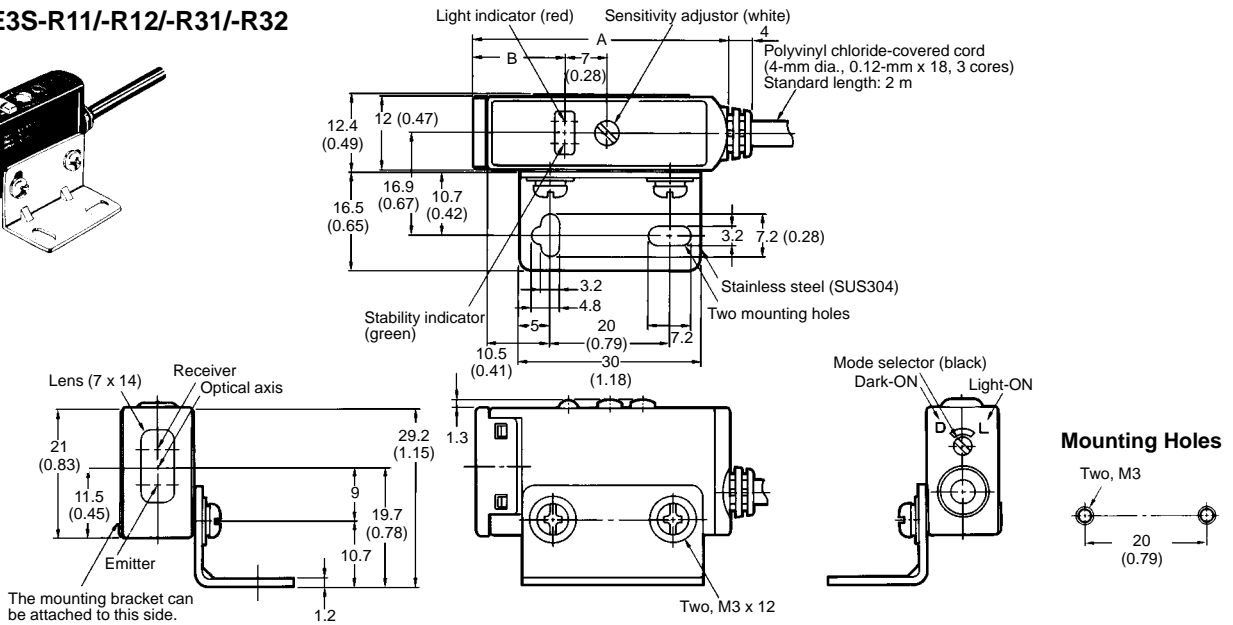
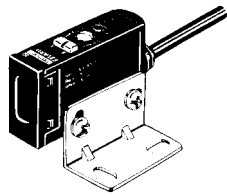

Type	NPN output	E3S-R11	E3S-R12
	PNP output	E3S-R31	E3S-R32
Size	A	42.3 (1.67)	40 (1.57)
	B	15.2 (0.60)	12.9 (0.51)

E3S-R61/-R62/-R81/-R82

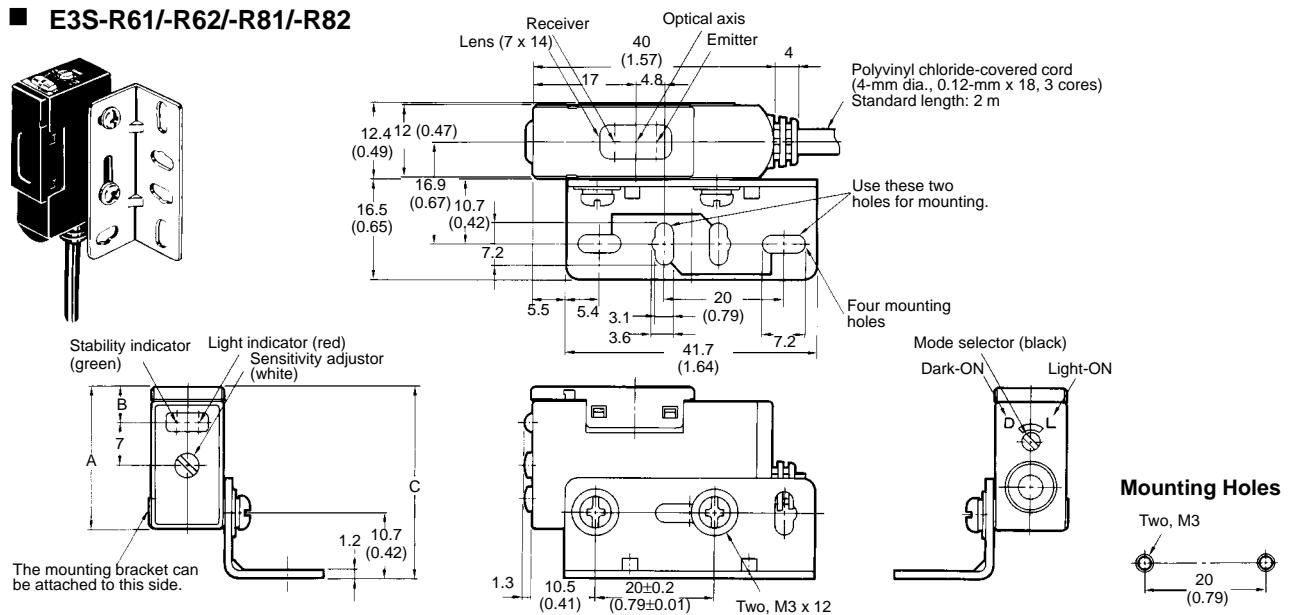
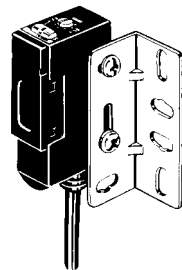

Type	NPN output	E3S-R61	E3S-R62
	PNP output	E3S-R81	E3S-R82
Size	A	23.3 (0.92)	21 (0.83)
	B	5.9 (0.23)	3.6 (0.14)
	C	31.5 (1.24)	29.2 (1.15)

■ E3S-R16/-R17/-R36/-R37

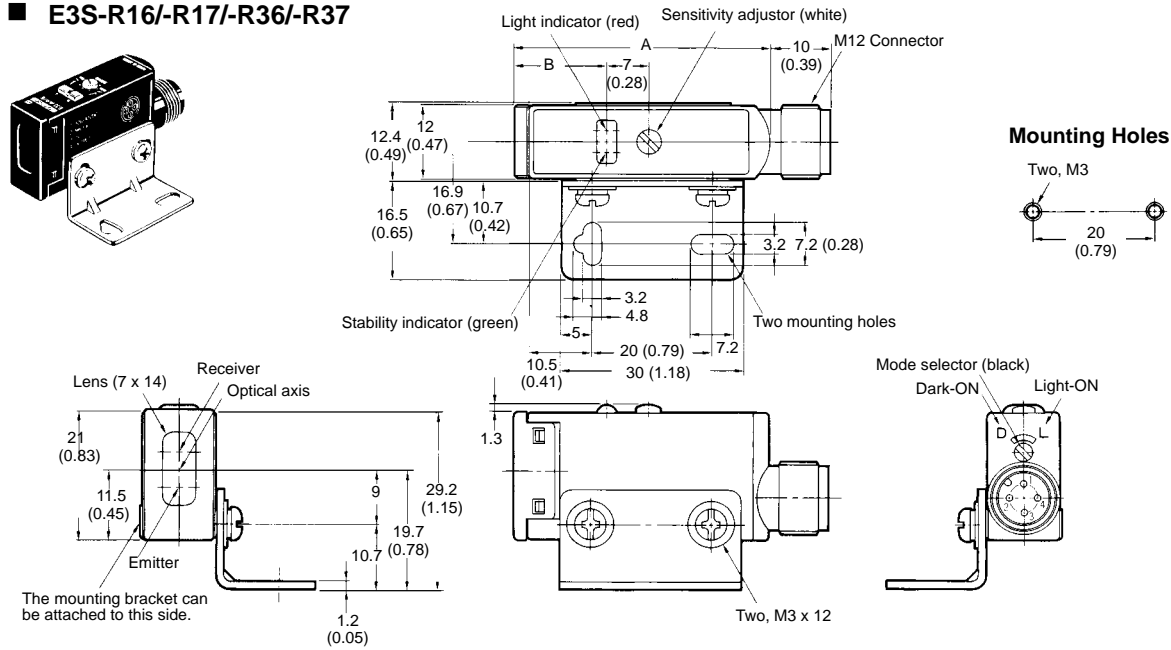

Type	NPN output	E3S-R16	E3S-R17
	PNP output	E3S-R36	E3S-R37
Size	A	42.3 (1.67)	40 (1.57)
	B	15.2 (0.60)	12.9 (0.51)

■ E3S-R66/-R67/-R86/-R87

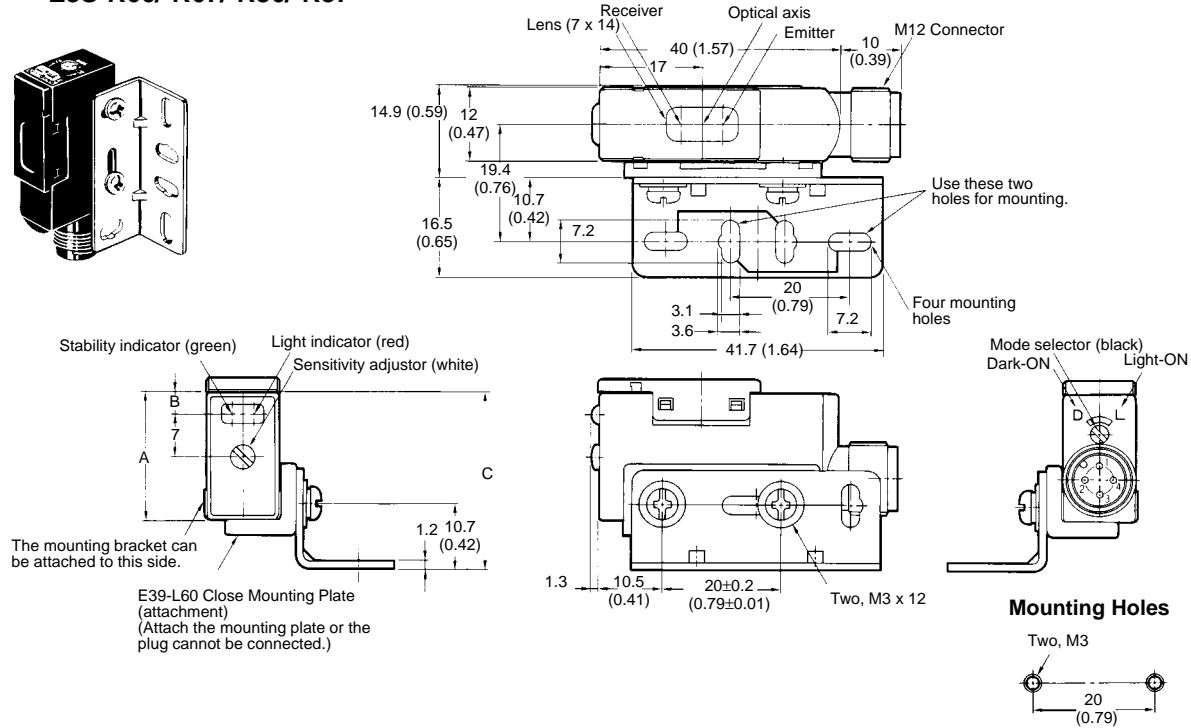

Type	NPN output	E3S-R66	E3S-R67
	PNP output	E3S-R86	E3S-R87
Size	A	23.3 (0.92)	21 (0.83)
	B	5.9 (0.23)	3.6 (0.14)
	C	31.5 (1.24)	29.2 (1.15)

■ ACCESSORIES

E39-R1 Retroreflector (Attachment)

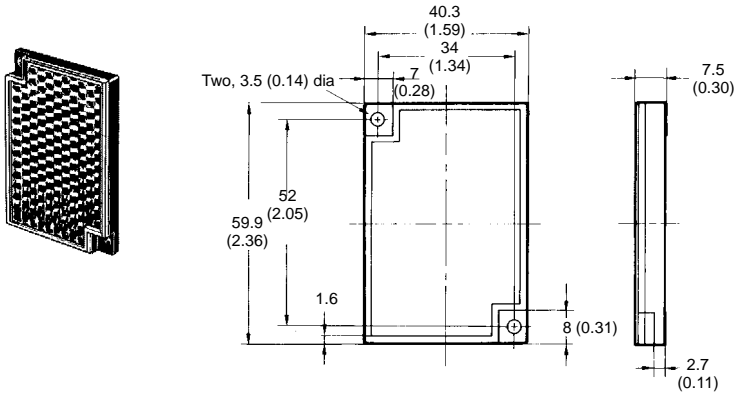

E39-G1 Sensitivity Adjustor Knob for the E3S-RS30 and E3S-R1□□□/R1B□□ (Attachment)

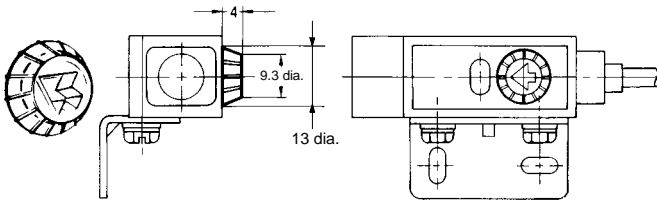

E39-G2 Sensitivity Adjustor Knob for E3S-R□□

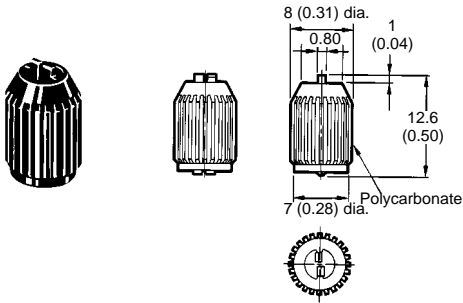

Connecting Method of the Sensitivity Adjustor Knob

Press the sensitivity adjusting knob so that the pointer of the sensitivity adjusting knob is in the direction shown in the illustration to connect the sensitivity adjusting knob to the E3S-R.

Make sure to connect the sensitivity adjusting knob correctly. It is impossible to remove the sensitivity adjusting knob from the E3S-R after it is connected to the E3S-R.

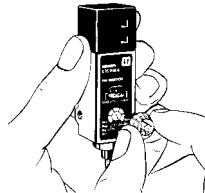

E39-L2 Special Mounting Bracket for the E3S-RS30 and E3S-R1(Order Separately)

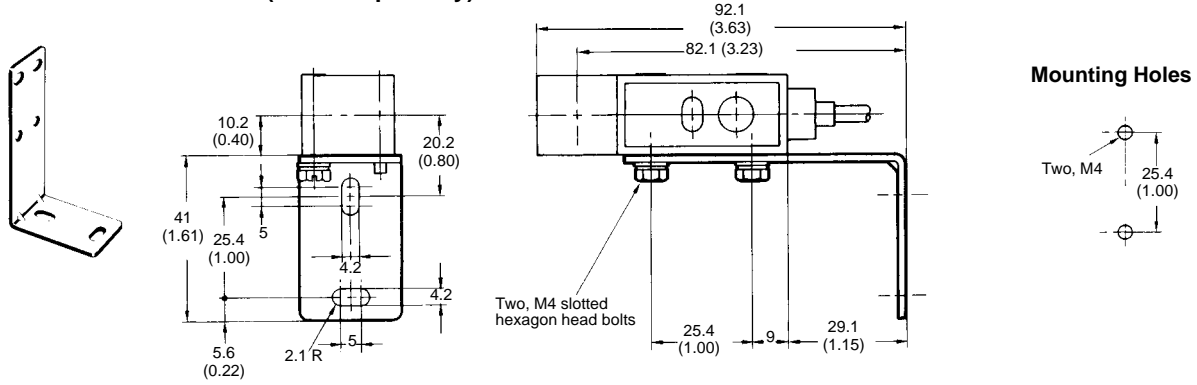

E39-L69 Mounting Bracket for E3S-R□□ Horizontal Type (Attachment)

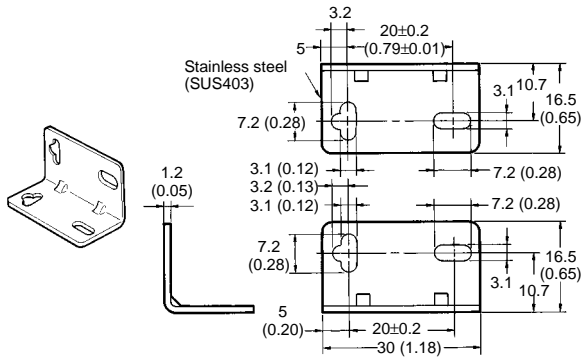

E39-L70 Mounting Bracket for E3S-R□□ Vertical Type (Attachment)

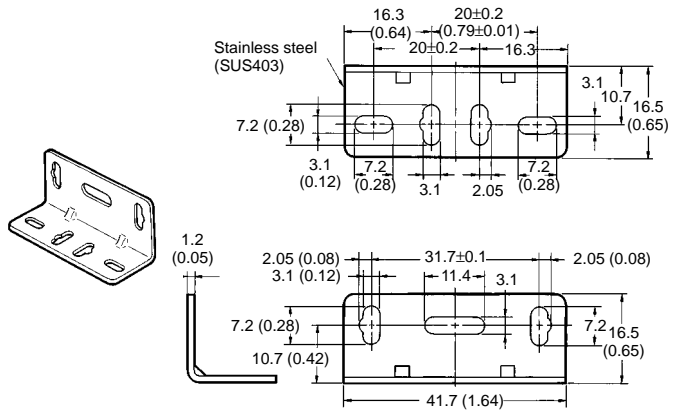

E39-L60 Contact Mounting Plate for E3S-R□□ Plug-in Connector Type (Order Separately)

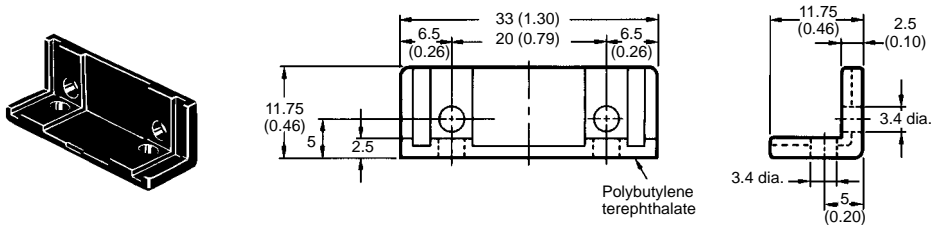

■ ACCESSORIES (ORDER SEPARATELY)

E39-L59 Vertical Mounting Bracket for E3S-R□□

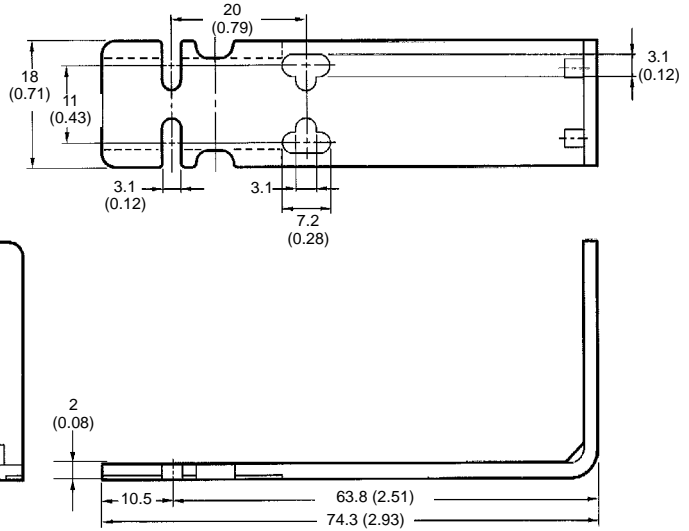
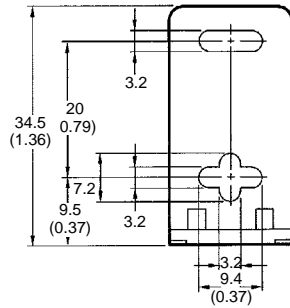
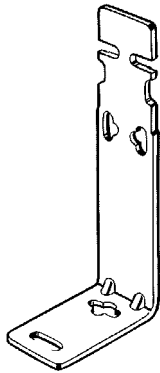

Installation

■ CONNECTIONS

If the brown and blue lead wires are connected in reverse, the output mode can be changed for the E3S-RS30E□□ and E3S-R1E□□/R1B□□ (Light-ON, Dark-ON).

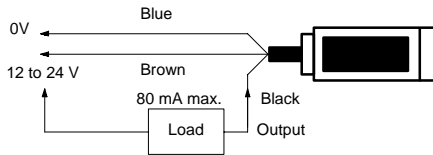

With S3D2 Sensor Controller

The E3S-R will operate in reverse using the signal input selector of the S3D2.

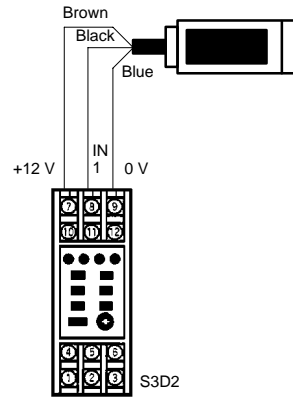

■ PLUG (FOR E3S-R WITH CONNECTOR)

Internal Connection

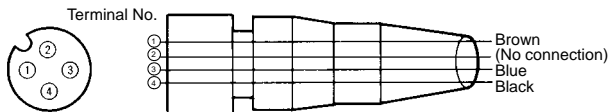

Item	Color of Cord	Conection Pin No.	Application
For DC	Brown	1	Power supply (+V)
	Black	4	Output
	Blue	3	Power supply (0 V)
	---	2	No connection

Precautions

DEFINITIONS OF PRECAUTIONARY INFORMATION

! DANGER! Indicates an imminently hazardous situation which, if not avoided, will result in death or serious injury. Limited to most extreme situations.

! WARNING Indicates a potentially hazardous situation which, if not avoided, could result in death or serious injury.

! Caution Indicates a potentially hazardous situation which, if not avoided, may result in minor or moderate injury. May also be used to alert against unsafe practices and property damage-only accidents.

! WARNING

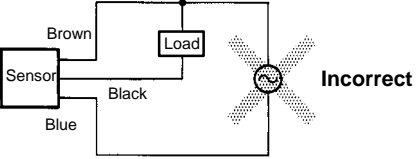
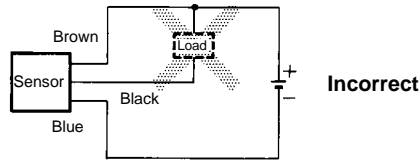
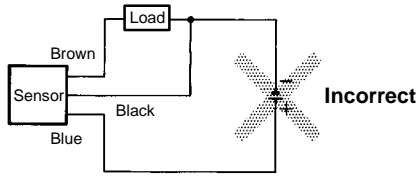
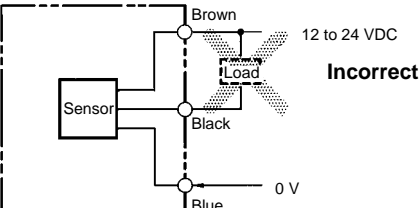
Item	Examples
<p>Power supply</p> <p>Do not impose an excessive voltage on the E3S-R, otherwise it may explode or burn. Do not impose 100 VAC on any E3S-R DC model, otherwise it may explode or burn.</p>	
<p>Load short-circuit</p> <p>Do not short-circuit the load, or the E3S-R may explode or burn. The E3S-R's short-circuit protection function is valid if the polarity of the supply voltage imposed is correct and within the rated voltage range.</p>	
<p>Wiring</p> <p>Be sure to wire the E3S-R and load correctly, otherwise it may explode or burn.</p>	
<p>Connection with no load</p> <p>Make sure to connect a proper load to the E3S-R in operation, otherwise it may explode or burn.</p>	

■ ADJUSTMENT

When the E3S-R senses a cylindrical object, the amount of light received varies with the direction of the cylindrical object. To prevent this, locate the E3S-R as shown in the following illustration.

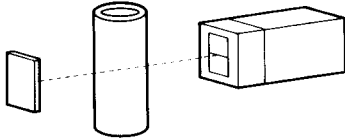

When the E3S-R senses an uneven plastic container or glass bottle, the amount of light received varies with the direction and sensing part of the plastic container or glass bottle. To prevent this, turn a sample of the plastic container or glass bottle to the best sensing position of the E3S-R to find and decide the optimum direction and sensing part, and then make the sensitivity adjustment.

In principle, sensing objects must pass through the center between the E3S-R and the reflector. Sensing objects must not be too close to the reflector, otherwise sensing errors may result.

■ INSTALLATION

Power Reset Time

The Photoelectric Sensor is ready to operate within 100 ms after power is supplied. If power supplies are connected to the Photoelectric Sensor and load respectively, be sure to supply power to the Photoelectric Sensor before supplying power to the load.

Power OFF

The Photoelectric Sensor may output a pulse signal when it is turned off. Therefore, it is recommended to turn off the load before turning off the Photoelectric Sensor.

Types of Power Supplies

The Photoelectric Sensor must not be connected to a non-smoothed, all-wave or half-wave rectified power supply.

■ WIRING

Cord

The cord can be extended up to 100 m provided that the thickness of the cord is 0.3 mm² maximum.

Repeated Bending

The cable must not be bent repeatedly.

High-tension Lines

The power supply lines of the Photoelectric Sensor must not be wired along side power lines or high-tension lines in the same conduit, otherwise the Photoelectric Sensor may become damaged or malfunction due to induction noise that may be generated from the power lines or high-tension lines.

Cord Traction Force

Do not pull cords with the tractive forces exceeding the following.

Diameter	Tractive Force
4 dia. max.	30 N max.
4 dia. min.	50 N max.

Note: Do not impose tensile stress on any shielded wire or coaxial cable.

Unused Lead Wired

Cut any unused lead wire of the Photoelectric Sensor, such as a lead wire for self-diagnostic output, and insulate the lead wire with insulating tape so that the wire will not touch any terminal of the Photoelectric Sensor.

NOTE: DIMENSIONS SHOWN ARE IN MILLIMETERS. To convert millimeters to inches divide by 25.4.

OMRON®

Omron Europe B.V. EMA-ISD, tel:+31 23 5681390, fax:+31 23 5681397, <http://www.eu.omron.com/ema>