

Non Safety Picking Sensor

# F3W-D

- Sensing distance of 3 m.
- Selectable display mode (all lighting, all flashing, elevator-like lighting, accordion-like lighting).
- Six picking indicators provide a very clear display.
- Selectable display speed (SLOW/FAST).
- External picking indicators may be connected.
- External indicators can be directly connected to the Picking Sensor and mounted in an easy-to-see location.

*Compact, Resistant to Mutual Interference, and Ideal for Picking a Variety of Parts*



## Ordering Information

### Sensors

Sensing method	Appearance	Connection method	Sensing distance	Optical-axis pitch	No. of optical axes	Detecting height (mm)	Output type	External indicator	Model
Through-beam		Pre-wired (5 m)		25 mm	5	100	NPN open collector	---	F3W-D052A
		Possible						F3W-D052AP	
		---						F3W-D052B	
		Possible						F3W-D052BP	
		PNP open collector					---	F3W-D052C	
							Possible	F3W-D052CP	
							---	F3W-D052D	
							Possible	F3W-D052DP	





**WARNING:**

Do not apply F3W-D as safety mechanisms used in pressing machines or any other safety mechanisms for protecting the human body from danger

Accessories (Sold Separately)

Mounting Brackets

Appearance	Model	Quantity	Remarks
	F39-L10	2	L-shaped Mounting Bracket
	F39-L11	2	Flat Mounting Bracket

Protective Bracket

Appearance	Model	Quantity
	F39-L12	One each for Emitter and Receiver (mounting screws included)

Y-shaped Joint Plugs and Sockets (Double-ended Connectors)

Appearance	Overall length	Model	Quantity
	2 m	XS2R-D526-S001-2	1
	5 m	XS2R-D526-S001-5	1

Y-shaped Joint Plugs and Sockets without Cable

Appearance	Model	Quantity	Remarks
	XS2R-D526-S003	1	Connecting cable: Double-ended connector: XS2W Series Single-ended connector: XS2F-series 4-conductor models

Specifications

Ratings / Characteristics

PNP Output

Item	Through-beam	
	F3W-D052C(P) (see note 1)	F3W-D052D(P) (see note 1)
Sensing distance	3 m, switchable between LONG mode (1 to 3 m) and SHORT mode: (0.05 to 1 m), factory-set to SHORT mode	
Optical-axis pitch	25 mm	
No. of optical axes	5	
Detecting height	100 mm	
Sensing object	Opaque, 35 mm dia. min.,	
Light source (wavelength)	Infrared LED (860 nm)	
Power supply voltage	12 to 24 VDC±10% (ripple range (p-p): 10% max.)	
Power consumption	Emitter: 0.6 W max., Receiver: 0.7 W max.	
Control output	PNP open collector with 100 mA max. at 30 VDC Residual voltage: 2.5 V max. at 100 mA Dark ON or Light ON (selectable)	
Picking instruction indicator input	Open collector with relay or transistor input Indicator ON: Input voltage of 0 to 2 V Indicator OFF: Open (with leakage current of 0.1 mA max.)	
Protection circuit	Reverse-connection protection, output short protection, and mutual interference interrupting function (set with frequency selector switch)	
Response time	Operate/Release: 10 ms max.	
Indicator	Receiver	Operation indicator (orange), stability indicator (green), and 6 picking indicators (orange)
	Emitter	Power indicator (green), different frequency indicator (green), and 6 picking indicators (orange)
Ambient temperature	Operating: -10° to 55°C Storage: -25° to 70°C (with no icing or condensation)	
Ambient humidity	35 to 85% (with no condensation)	
Insulation resistance	20 M min. (at 500 VDC)	
Dielectric strength	1,000 VAC 50/60 Hz for 1 min	
Vibration resistance	Destruction: 10 to 50 Hz, 1.5-mm double-amplitude for 2 hours each in X, Y and Z directions	
Shock resistance	Destruction: 500 m/s <sup>2</sup> , 3 times each in X, Y and Z directions	
Degree of protection	IEC60529: IP62 (with the operation cover closed)	
Connection method	Pre-wired Standard cable length: 5 m	Connector (M12 5-pin connector) Standard cable length: 2 m
Weight (including package)	Approx. 360 g	Approx. 230 g
Materials	Case, display window	ABS resin
	Lens	Acrylic resin
	Operation cover	Nylon (PA6)
Accessories	Instruction manual	

Note: 1. The F3W-D052□P Emitters are provided with the external picking indicator output line shown in the following table.

Item	F3W-D052CP, F3W-D052DP
Connection method	Pre-wired with connector (standard cable length: 300 mm) Connector model: SMP-02V-NC (manufactured by Nihon Crimp Terminal, Ltd.)
Electrical specifications	Output current: 50 mA max. Output voltage: Fixed at sensor power supply voltage

NPN Output

Item	Through-beam	
	F3W-D052A(P) (see note 1)	F3W-D052B(P) (see note 1)
Sensing distance	3 m, switchable between LONG mode (1 to 3 m) and SHORT mode: (0.05 to 1 m), factory-set to SHORT mode	
Optical-axis pitch	25 mm	
No. of optical axes	5	
Detecting height	100 mm	
Sensing object	Opaque, 35 mm dia. min.,	
Light source (wavelength)	Infrared LED (860 nm)	
Power supply voltage	12 to 24 VDC±10% (ripple range (p-p): 10% max.)	
Power consumption	Emitter: 0.6 W max., Receiver: 0.7 W max.	
Control output	NPN open collector with 100 mA max. at 30 VDC Residual voltage: 1 V max. at 100 mA Dark ON or Light ON (selectable)	
Picking instruction indicator input	Open collector with relay or transistor input Indicator ON: Input voltage of 0 to 2 V Indicator OFF: Open (with leakage current of 0.1 mA max.)	
Protection circuit	Reverse-connection protection, output short protection, and mutual interference interrupting function (set with frequency selector switch)	
Response time	Operate/Release: 10 ms max.	
Indicator	Receiver	Operation indicator (orange), stability indicator (green), and 6 picking indicators (orange)
	Emitter	Power indicator (green), different frequency indicator (green), and 6 picking indicators (orange)
Ambient temperature	Operating: -10° to 55°C Storage: -25° to 70°C (with no icing or condensation)	
Ambient humidity	35 to 85% (with no condensation)	
Insulation resistance	20 M min. (at 500 VDC)	
Dielectric strength	1,000 VAC 50/60 Hz for 1 min	
Vibration resistance	Destruction: 10 to 50 Hz, 1.5-mm double-amplitude for 2 hours each in X, Y and Z directions	
Shock resistance	Destruction: 500 m/s <sup>2</sup> , 3 times each in X, Y and Z directions	
Degree of protection	IEC60529: IP62 (with the operation cover closed)	
Connection method	Pre-wired Standard cable length: 5 m (see note 2)	Connector (M12 5-pin connector) Standard cable length: 2 m (see note 2)
Weight (including package)	Approx. 360 g	Approx. 230 g
Materials	Case, display window	ABS resin
	Lens	Acrylic resin
	Operation cover	Nylon (PA6)
Accessories	Instruction manual	

Note: 1 . The F3W-D052□P Emitters are provided with the external picking indicator output line shown in the following table.

Item	F3W-D052AP, F3W-D052BP
Connection method	Pre-wired with connector (standard cable length: 300 mm) Connector model: SMP-02V-NC (manufactured by Nihon Crimp Terminal, Ltd.)
Electrical specifications	Output current: 50 mA max. Output voltage: Fixed at sensor power supply voltage

2 . The following cable lengths are also available.  
F3W-D052A(P): 2 m, 7 m  
F3W-D052B(P): 1 m, 3.5 m

Engineering Data

Parallel Operating Range  
(Typical)

LONG Mode

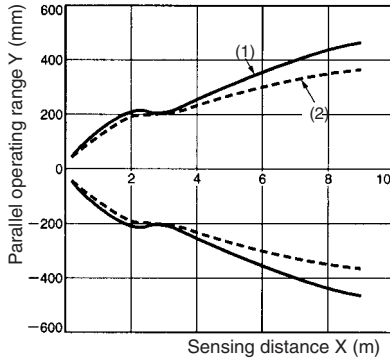

SHORT Mode

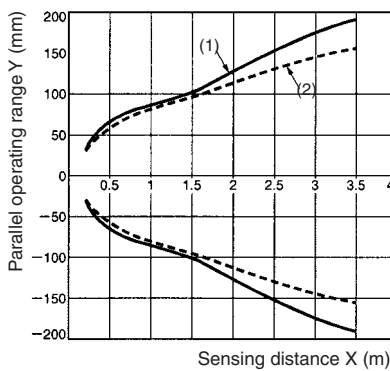

(1) Horizontal Movement Characteristics

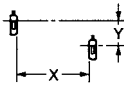

(2) Vertical Movement Characteristics

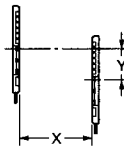

Angle Characteristics  
(Typical)

LONG Mode: Direction of Swing

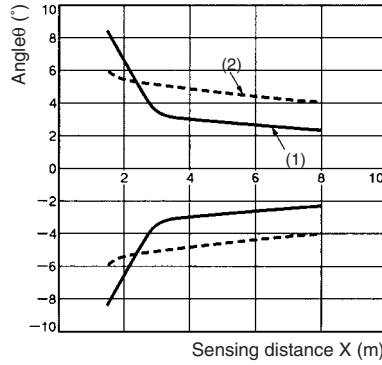

SHORT Mode: Direction of Swing

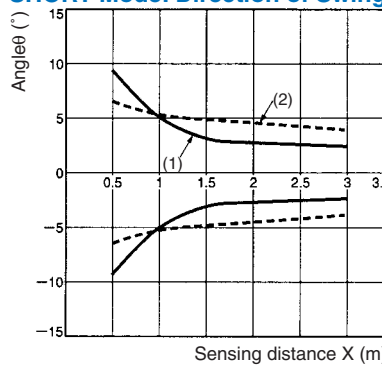

(1) Emitter Angle Characteristics

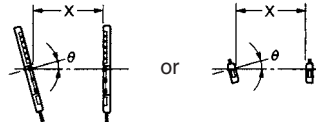

(Direction of swing) (Direction of rotation)

(2) Receiver Angle Characteristics

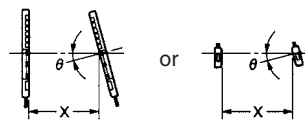

(Direction of swing) (Direction of rotation)

LONG Mode: Direction of Rotation

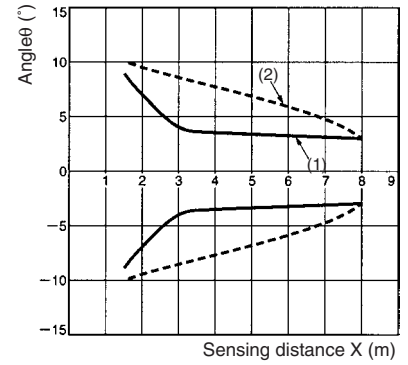

SHORT Mode: Direction of Rotation

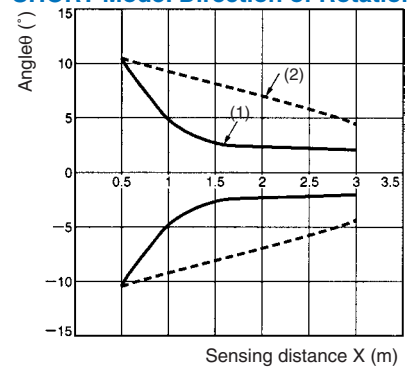

Nomenclature

NPN Open Collector Output Models

Emitter

F3W-D052A(P)-L  
F3W-D052B(P)-L

Receiver

F3W-D052A(P)-D  
F3W-D052B(P)-D

PNP Open Collector Output Models

Emitter

F3W-D052C(P)-L  
F3W-D052D(P)-L

Receiver

F3W-D052C(P)-D  
F3W-D052D(P)-D

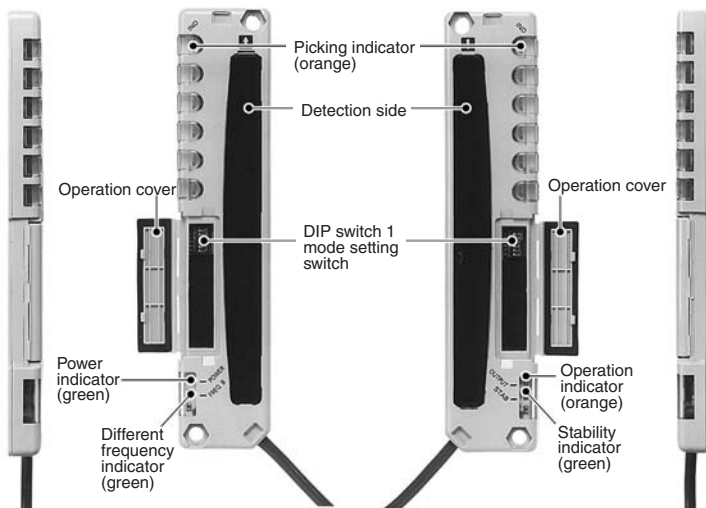

Operation

Output Circuits NPN

Output form	NPN open collector output																			
Model	F3W-D052A, F3W-D052AP, F3W-D052B, F3W-D052BP																			
State of output transistor	<b>Dark-ON mode</b> ON: One optical axis or more is interrupted OFF: No optical axis is interrupted	<b>Light-ON mode</b> ON: No optical axis is interrupted OFF: One optical axis or more is interrupted																		
Timing chart																				
Mode Selector	D.ON (Dark-ON)	L.ON (Light-ON)																		
Output circuit	<p>*1 The sections surrounded by single-dashed lines are applicable to the F3W-D052AP-L/BP-L only.                  *2 The circled numbers represent external picking indicator output pin numbers for a connector relay type.</p> <p>The following diagram shows the relationship between picking instruction input, picking indicator status, and external picking indicator output. DIP switch 1 is used to switch the picking display mode between all lighting, all flashing, elevator-like lighting, and accordion-like lighting. It is also possible to switch the external picking indicator display mode between lighting and flashing.</p> <table border="0"> <tr> <td>Picking instruction input</td> <td>Open</td> <td></td> </tr> <tr> <td></td> <td>0 V</td> <td></td> </tr> <tr> <td>Picking indicator</td> <td>ON</td> <td></td> </tr> <tr> <td></td> <td>OFF</td> <td></td> </tr> <tr> <td>External picking indicator output</td> <td>ON</td> <td></td> </tr> <tr> <td></td> <td>OFF</td> <td></td> </tr> </table>		Picking instruction input	Open			0 V		Picking indicator	ON			OFF		External picking indicator output	ON			OFF	
Picking instruction input	Open																			
	0 V																			
Picking indicator	ON																			
	OFF																			
External picking indicator output	ON																			
	OFF																			

Output Circuits PNP

Output form	PNP open collector output	
Model	F3W-D052C, F3W-D052CP, F3W-D052D, F3W-D052DP	
State of output transistor	<b>Dark-ON mode</b> ON: One optical axis or more is interrupted OFF: No optical axis is interrupted	<b>Light-ON mode</b> ON: No optical axis is interrupted OFF: One optical axis or more is interrupted
Timing chart	<p>Light incident: No optical axis is interrupted (High pulse), One optical axis or more is interrupted (Low pulse)</p> <p>Operation indicator (orange): ON (High pulse), OFF (Low pulse)</p> <p>Control output: ON (High pulse), OFF (Low pulse)</p> <p>Load (relay, etc.): Operate (High pulse), Release (Low pulse)</p>	<p>Light incident: No optical axis is interrupted (High pulse), One optical axis or more is interrupted (Low pulse)</p> <p>Operation indicator (orange): ON (High pulse), OFF (Low pulse)</p> <p>Control output: ON (High pulse), OFF (Low pulse)</p> <p>Load (relay, etc.): Operate (High pulse), Release (Low pulse)</p>
Mode Selector	D.ON (Dark-ON)	L.ON (Light-ON)
Output circuit	<p>※The inside of the speck chain line is only F3W-D052CP-L/DP-L. Numerical value inside parenthesis,( ),indicates a pin number of the connector of the sensor.</p>	



Dimensions

F3WD

Emitter

- F3W-D052A(P)-L
- F3W-D052B(P)-L
- F3W-D052C(P)-L
- F3W-D052D(P)-L



Two, M4 nut holes  
(Depth: 1 mm)

Six picking indicators (orange)

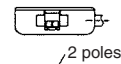

Vinyl-insulated round cable, 4 dia.  
Standard length: 0.3 m

Mounting Hole Dimensions

Two, M4 holes

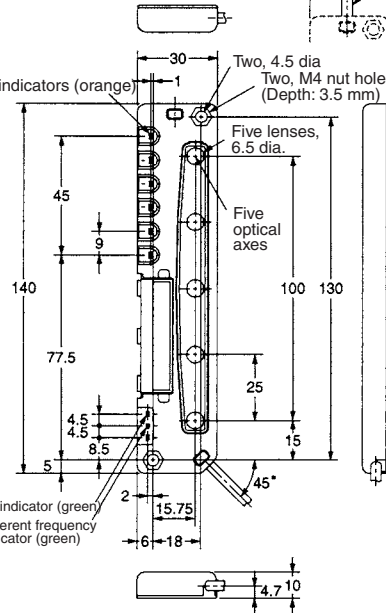

130±0.15

18±0.1

F3W-D052B(P)-L:  
Vinyl-insulated round  
cable, 4 dia.  
Standard length: 2 m

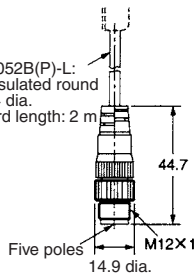

F3W-D052A(P)-L:  
Vinyl-insulated round cable with  
four conductors, 4 dia.  
Conductor: 0.2 mm.  
Insulation: 1.1 mm dia.  
Standard length: 5 m

Receiver

- F3W-D052A(P)-D
- F3W-D052B(P)-D
- F3W-D052C(P)-D
- F3W-D052D(P)-D

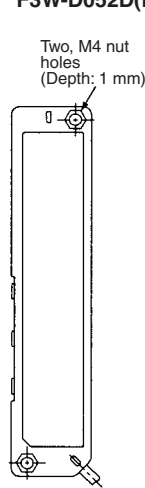

Mounting Hole Dimensions

Two, M4 holes

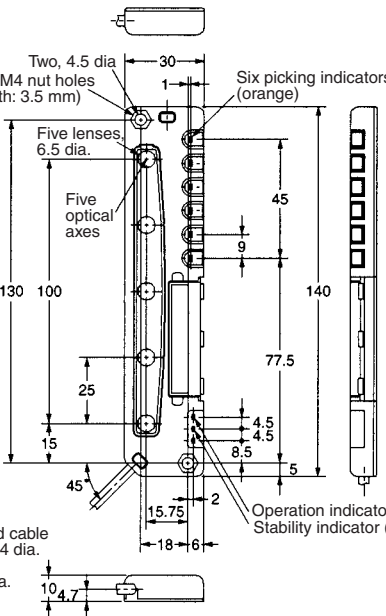

130±0.15

18±0.1

F3W-D052B(P)-D:  
Vinyl-insulated round  
cable, 4 dia.  
Standard length: 2 m

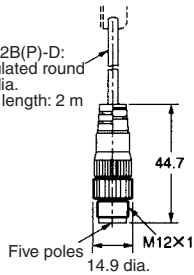

F3W-D052A(P)-D:  
Vinyl-insulated round cable  
with five conductors, 4 dia.  
Conductor: 0.2 mm.  
Insulation: 1.1 mm dia.  
Standard length: 5 m

Operation indicator (orange)  
Stability indicator (green)

Note: All units are in millimeters unless otherwise indicated

Accessories (Sold Separately)

Mounting Brackets

F39-L10 (L-shaped)

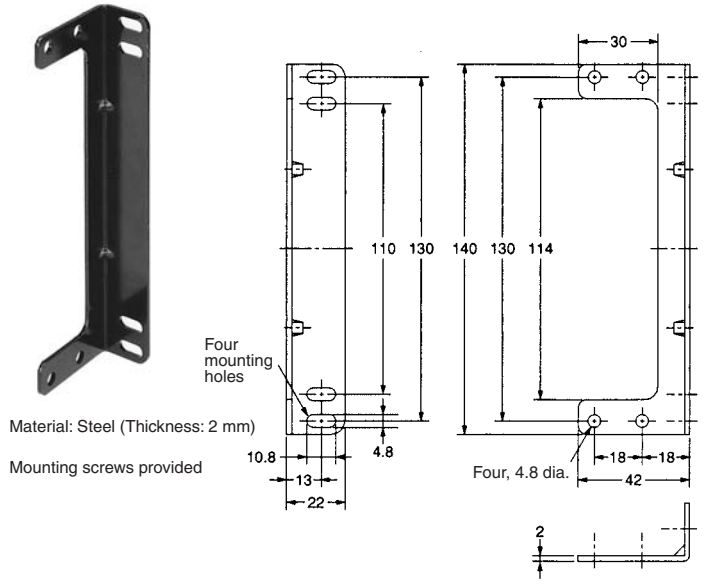

F3W-D052A-D with Mounting Bracket

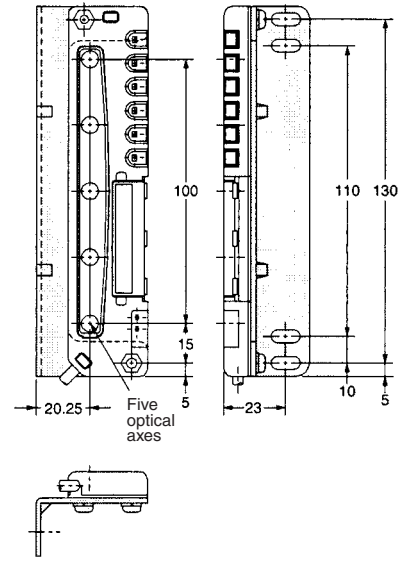

F39-L11 (Flat)

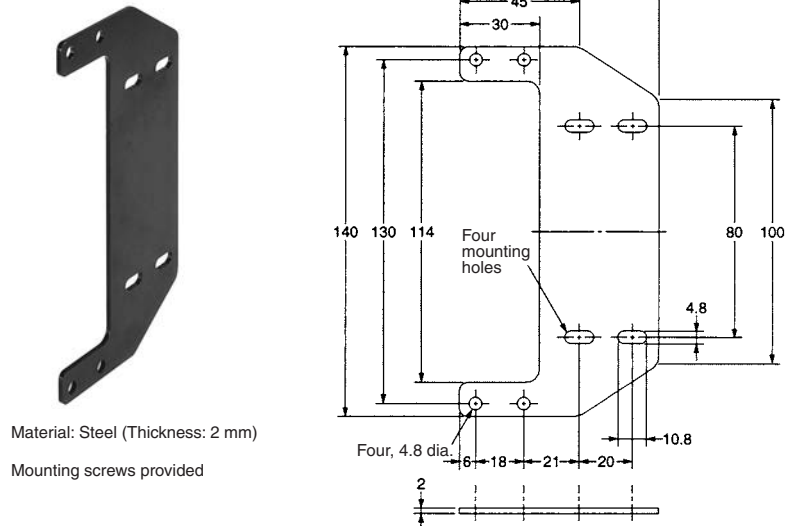

F3W-D052A-D with Mounting Bracket

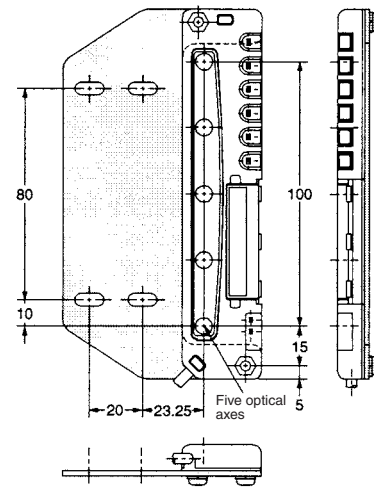

Protective Bracket

F39-L12 (Receiver)

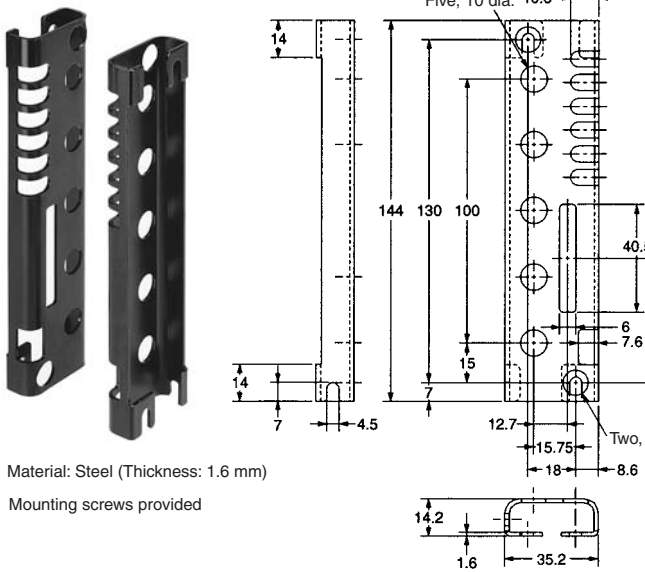

Material: Steel (Thickness: 1.6 mm)

Mounting screws provided

Note: The Emitter and Receiver are axially symmetrical.

Y-shaped Joint Plugs and Sockets (Double-ended Connectors)

XS2R-D526-S001-2 (L=2,000 mm)  
XS2R-D526-S001-5 (L=5,000 mm)

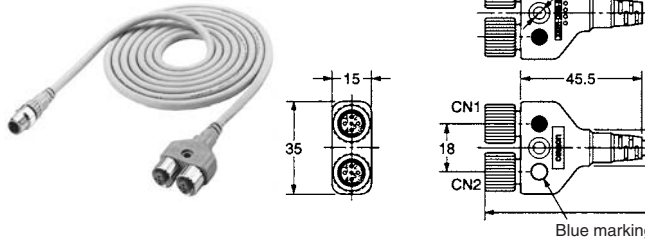

Y-shaped Joint Plugs and Sockets without cable

XS2R-D526-S003

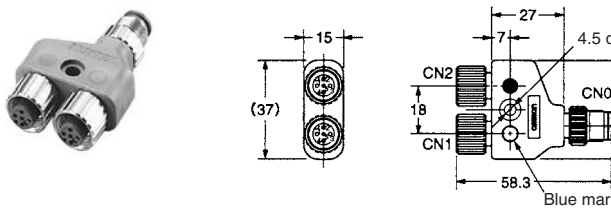

## Precautions

### ⚠ Warning:

Do not apply the F3W-D as safety mechanisms used in pressing machines or any other safety mechanisms for protecting the human body from danger.

1. Do not apply the F3W-D as safety mechanisms used in pressing machines, shears, rolling machines, spinning machines, cotton mill machines, or robots for the protection of an operator's hands and body
2. The F3W-D is designed for detection of the human body or moving objects in the detection area but not for protection against danger.
3. The F3W-D or any product incorporating the F3W-D may be exported to any country. Should the F3W-D cause any problem conflicting with the local law or related to product liability locally, however, OMRON shall, without exception, assume no responsibility for it.

### ⚠ Caution

Before using more than one F3W-D Unit in parallel or serial, take necessary countermeasures against mutual interference so that the unit will not malfunction. Refer to *Mutual Interference Attenuating Function*.

## General Precautions

### Supply Voltage

Make sure that the supply voltage is within the rated range. If the supply voltage is not within the rated range or 100 VAC is imposed on a DC Sensor model, the Sensor may be damaged or malfunction.

### Load Short-circuiting

Do not short-circuit the load, otherwise the Sensor may be damaged or malfunction.

### Incorrect Wiring

Do not make mistakes in the polarity of power supply or wiring, otherwise the Sensor may be damaged or malfunction.

### Connection without Load

Make sure that the load is connected to the Sensor in operation, otherwise the Sensor may be damaged or malfunction.

### Operating Environment

Do not use the Sensor in an environment containing flammable or explosive gases.

Do not use the Sensor underwater.

Do not disassemble, repair, or modify the Sensor.

Always turn OFF the system power before installing or replacing the Sensor.

## System Design

### Cables

For both pre-wired and connector models, the maximum tensile force of cables must be 50 N.

### Wiring

If the Sensor cables are housed in the same conduit or duct as for high-voltage and power lines, the Sensor may be subject to induced current, resulting in malfunction or damage. For this reason, the Sensor cables must be separated from the high-voltage and power lines or housed in a separate conduit.

### Power ON Timing

It takes 100 ms for the Sensor to operate properly after it is turned ON. Therefore, other devices should be turned ON at least 100 ms after the Sensor is turned ON. If the Sensor and the load are connected to different power supplies, the Sensor power must be turned ON first.

### Power Supply

When using a commercially available switching regulator, always ground it to the frame ground (FG) or ground (G) terminal. Otherwise, switching noise may result in malfunctions.

### Mutual Interference Attenuating Function

#### 1. Two Sets of Sensors:

Set these Sensors to different frequencies with the frequency selector. Refer to *DIP Switch 1 Mode Switching* later in this datasheet.

If the mutual interference attenuating function is not used, and there are two Sensors with the same frequency setting, a beam from the Emitter of one Sensor may hit the Receiver of the other Sensor, resulting in malfunction.

This function cannot prevent mutual interference between the F3W-D Sensor and a Photoelectric Sensor of another model.

#### 2. Three or More Sets of Sensors:

When 3 or more sets of Sensors are used in parallel, mutual interference may result in malfunction. Take the following measures to prevent mutual interference, and check for mutual interference.

- While in LONG mode, the Sensors are more easily affected by interference. Therefore, if the distance between the Emitter and Receiver of a Sensor is 1 m or less, use the SHORT mode.
- The distance between two adjacent sets of Sensors must be at least  $l_1$  or  $l_2$ , which does not cause mutual interference between two Sensors with the same frequency setting.  $l_1$  or  $l_2$  is at least 1.5 times the distance shown in *Parallel Operating Range* of the *Engineering Data*.

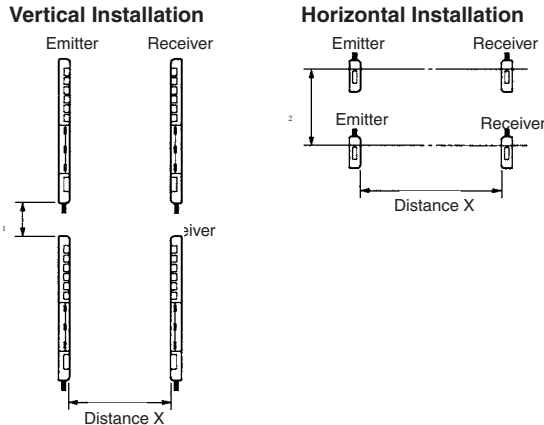

- Install a barrier so that there will not be mutual interference between Sensors with the same frequency setting. (See Figure 1.)

A light reflection from the wall or floor may go around a barrier and reach the Receivers. Install a barrier so that it will also block any light reflection. (See Figure 2.)

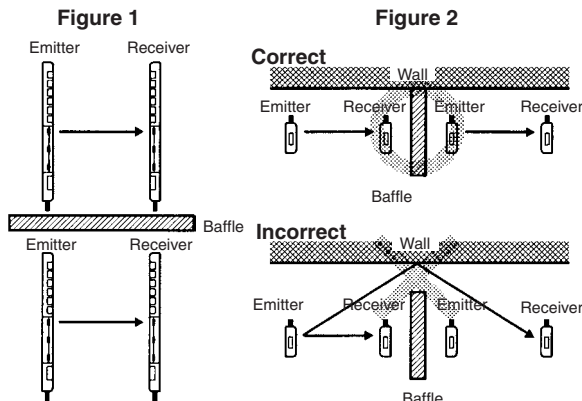

Correct Use

DIP Switch 1 Mode Switching Emitters

DIP switch 1	Function	OFF (left)	ON (right)	
	1	(See note 3.)		
	2	Picking display mode setting		
	3	SLOW	FAST	
	4	Lit	Flashing	
	5	NC	---	---
	6	Frequency setting (see note 2)	Frequency A	Frequency B

Receivers

DIP switch 1	Function	OFF (left)	ON (right)
	1	(See note 3.)	
	2	Picking display mode setting	
	3	SLOW	FAST
	4	Dark-ON	Light-ON
	5	LONG mode (1 to 3 m)	SHORT mode (0.05 to 1 m)
	6	Not used	---

- Note: 1. The flashing speed can be changed in picking display mode (all flashing, elevator-like lighting, or accordion-like lighting) or in external picking display mode. The flashing speed varies with each display mode.  
 2. Mutual Interruption Attenuating Function: The frequency selector is used to switch the emitting frequency between A and B. Making the emitting frequencies of two Sensors different prevents malfunction caused by mutual interference.  
 3. Picking Display Mode Setting of DIP Switch 1

DIP switch 1	Pin 1	Pin 2	Display mode
	OFF	OFF	All lighting (All six indicators are lit.)
	ON	OFF	All flashing (All six indicators flash simultaneously.)
	OFF	ON	Elevator-like lighting (Two adjacent indicators simultaneously light so that lighting moves up and down.)
	ON	ON	Accordion-like lighting (Some or all indicators simultaneously light so that lighting moves like an accordion.)

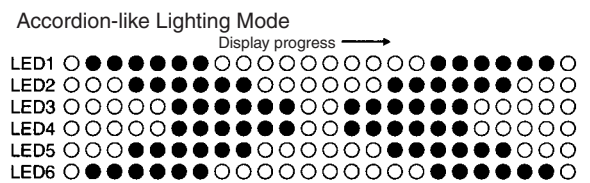
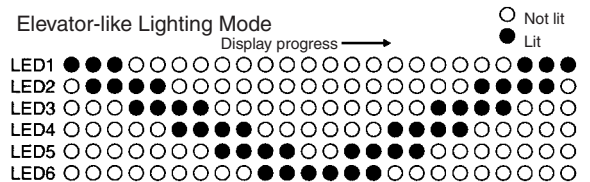

4. For F3W-D052jP-L Emitters only

Wiring

Before turning ON the power, make sure that the supply voltage is within the maximum allowable voltage range.

Always connect the sync lines.

Extension cables must be 0.3 mm<sup>2</sup> or more in cross-sectional area and 100 m or less in length (for the F3W-D052A(P) and F3W-D052B(P) only).

Be very careful not to get metal chips in the connector especially during wiring.

Incorrect wiring may damage the equipment. Make sure that the cable length and routing are appropriate to prevent the connectors and cables from getting disconnected.

Always leave the operation cover closed during operation. Applying excessive force to the mode selector switch may result in damage. Do not apply a force of more than 5 N.

**Cables**

Make sure that the bending radius is 25 mm or more.

**Installation**

Install the Sensor so that its sensing face will not receive light from the sun, fluorescent lamps, incandescent lamps, and other light sources.

Do not strike the Sensor with a hammer or any other tool during the installation, otherwise the internal circuitry of the Sensor may be damaged.

Install the Emitter and Receiver in the same orientation as shown in the following figure. (The cable pullout direction must be the same.)

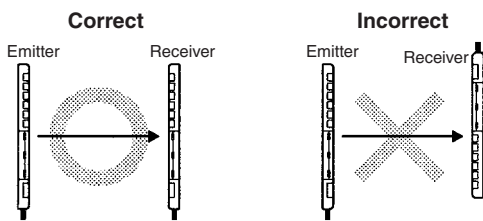

Use M4 screws to secure the Sensor body. Secure the case to a tightening torque of 1.2 Nxm or less.

**Reflection from Wall or Floor**

If the Emitter and Receiver are installed as shown in the following illustration, all the axes may not be interrupted due to light reflection from the floor or wall. Make sure that the Emitter and Receiver detect the sensing object properly before using the F3W-D in actual operation.

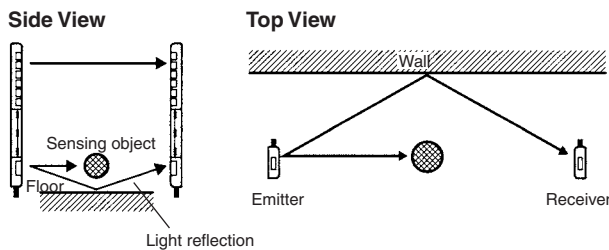

**M12 Connectors**

Always turn OFF the power before connecting or disconnecting an M12 connector.

Always connect or disconnect an M12 connector by holding its cover.

Always tighten the fixture by hand. Using pliers may result in damage.

Insufficient tightening may loosen the connector due to vibration, resulting in failure to ensure the specified degree of protection.

**Operation and Stability Status Display**

The following illustration shows the indicator status corresponding to each incident level.

Install the Receiver so that the green stability indicators are both ON in light receiving status.

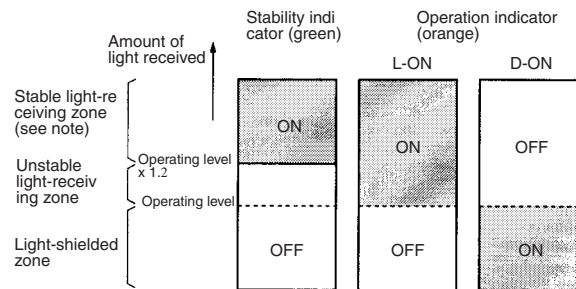

Note: If the Receiver is set to the stable light-receiving zone, it will become more resistant to environmental fluctuations such as temperature, voltage, dust, and setting deviation after installation. For applications where a stable light-receiving zone is not obtained, attention must be paid to environmental fluctuations.

**Installation Environment**

Do not install the F3W-D Sensor under the following conditions.

- Where direct sunlight is received
- Where humidity is high and there is a risk of condensation
- Where there are corrosive gases
- Where vibration and shock are directly transmitted to the Sensor

**Cleaning**

- Do not use organic solvents for cleaning. Otherwise, the surfaces of the Sensor will be eroded.
- Use a soft, dry cleaning cloth.

ALL DIMENSIONS SHOWN ARE IN MILLIMETERS.  
To convert millimeters into inches, multiply by 0.03937. To convert grams into ounces, multiply by 0.03527.

## Read and Understand This Catalog

Please read and understand this catalog before purchasing the products. Please consult your OMRON representative if you have any questions or comments.

## Warranty and Limitations of Liability

### WARRANTY

OMRON's exclusive warranty is that the products are free from defects in materials and workmanship for a period of one year (or other period if specified) from date of sale by OMRON.

OMRON MAKES NO WARRANTY OR REPRESENTATION, EXPRESS OR IMPLIED, REGARDING NON-INFRINGEMENT, MERCHANTABILITY, OR FITNESS FOR PARTICULAR PURPOSE OF THE PRODUCTS. ANY BUYER OR USER ACKNOWLEDGES THAT THE BUYER OR USER ALONE HAS DETERMINED THAT THE PRODUCTS WILL SUITABLY MEET THE REQUIREMENTS OF THEIR INTENDED USE. OMRON DISCLAIMS ALL OTHER WARRANTIES, EXPRESS OR IMPLIED.

### LIMITATIONS OF LIABILITY

OMRON SHALL NOT BE RESPONSIBLE FOR SPECIAL, INDIRECT, OR CONSEQUENTIAL DAMAGES, LOSS OF PROFITS, OR COMMERCIAL LOSS IN ANY WAY CONNECTED WITH THE PRODUCTS, WHETHER SUCH CLAIM IS BASED ON CONTRACT, WARRANTY, NEGLIGENCE, OR STRICT LIABILITY.

In no event shall responsibility of OMRON for any act exceed the individual price of the product on which liability is asserted.

IN NO EVENT SHALL OMRON BE RESPONSIBLE FOR WARRANTY, REPAIR, OR OTHER CLAIMS REGARDING THE PRODUCTS UNLESS OMRON'S ANALYSIS CONFIRMS THAT THE PRODUCTS WERE PROPERLY HANDLED, STORED, INSTALLED, AND MAINTAINED AND NOT SUBJECT TO CONTAMINATION, ABUSE, MISUSE, OR INAPPROPRIATE MODIFICATION OR REPAIR.

## Application Considerations

### SUITABILITY FOR USE

OMRON shall not be responsible for conformity with any standards, codes, or regulations that apply to the combination of products in the customer's application or use of the product.

At the customer's request, OMRON will provide applicable third party certification documents identifying ratings and limitations of use that apply to the products. This information by itself is not sufficient for a complete determination of the suitability of the products in combination with the end product, machine, system, or other application or use.

The following are some examples of applications for which particular attention must be given. This is not intended to be an exhaustive list of all possible uses of the products, nor is it intended to imply that the uses listed may be suitable for the products:

- Outdoor use, uses involving potential chemical contamination or electrical interference, or conditions or uses not described in this catalog.
- Nuclear energy control systems, combustion systems, railroad systems, aviation systems, medical equipment, amusement machines, vehicles, safety equipment, and installations subject to separate industry or government regulations.
- Systems, machines, and equipment that could present a risk to life or property.

Please know and observe all prohibitions of use applicable to the products.

NEVER USE THE PRODUCTS FOR AN APPLICATION INVOLVING SERIOUS RISK TO LIFE OR PROPERTY WITHOUT ENSURING THAT THE SYSTEM AS A WHOLE HAS BEEN DESIGNED TO ADDRESS THE RISKS, AND THAT THE OMRON PRODUCT IS PROPERLY RATED AND INSTALLED FOR THE INTENDED USE WITHIN THE OVERALL EQUIPMENT OR SYSTEM.

## Disclaimers

### CHANGE IN SPECIFICATIONS

Product specifications and accessories may be changed at any time based on improvements and other reasons.

It is our practice to change model numbers when published ratings or features are changed, or when significant construction changes are made. However, some specifications of the product may be changed without any notice. When in doubt, special model numbers may be assigned to fix or establish key specifications for your application on your request. Please consult with your OMRON representative at any time to confirm actual specifications of purchased product.

### DIMENSIONS AND WEIGHTS

Dimensions and weights are nominal and are not to be used for manufacturing purposes, even when tolerances are shown.

### ERRORS AND OMISSIONS

The information in this catalog has been carefully checked and is believed to be accurate; however, no responsibility is assumed for clerical, typographical, or proofreading errors, or omissions.

### PERFORMANCE DATA

Performance data given in this catalog is provided as a guide for the user in determining suitability and does not constitute a warranty. It may represent the result of OMRON's test conditions, and the users must correlate it to actual application requirements. Actual performance is subject to the OMRON Warranty and Limitations of Liability.

### PROGRAMMABLE PRODUCTS

OMRON shall not be responsible for the user's programming of a programmable product, or any consequence thereof.

### COPYRIGHT AND COPY PERMISSION

This catalog shall not be copied for sales or promotions without permission.

This catalog is protected by copyright and is intended solely for use in conjunction with the product. Please notify us before copying or reproducing this catalog in any manner, for any other purpose. If copying or transmitting this catalog to another, please copy or transmit it in its entirety.