

**FEMALE CAP
WITH CHAIN**

R143.812.000

Series : TNC

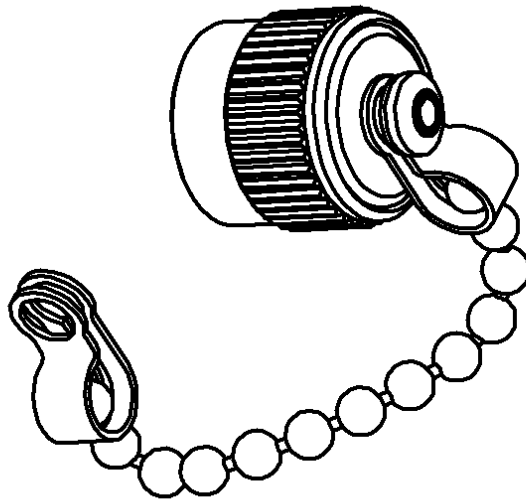
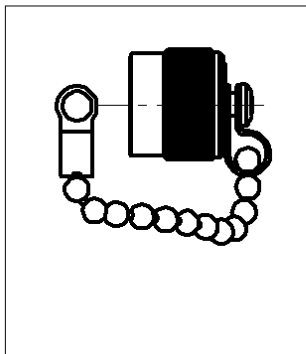
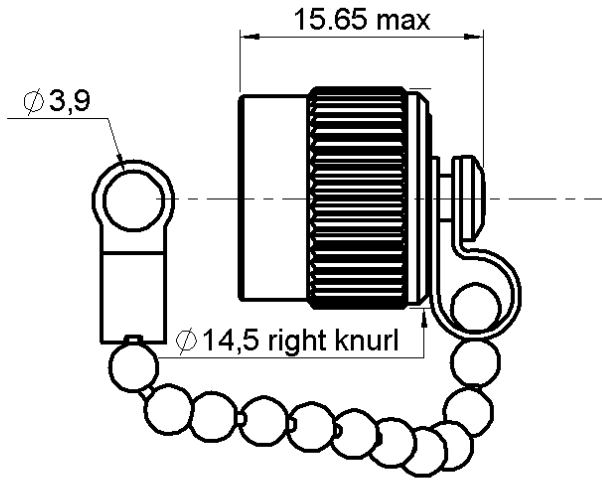

All dimensions are in mm.



COMPONENTS	MATERIALS	PLATINGS (μm)
BODY	BRASS	NICKEL 2
CENTER CONTACT	-	-
OUTER CONTACT	-	-
INSULATOR	-	-
GASKET	SILICONE RUBBER	-
OTHERS PARTS	BRASS	NICKEL 2
-	-	-
-	-	-

Issue : 0314 K

In the effort to improve our products, we reserve the right to make changes judged to be necessary.



**FEMALE CAP
WITH CHAIN**

R143.812.000

Series : TNC

PACKAGING

SPECIFICATION

Standard	Unit	Other
1	-	Contact us

ELECTRICAL CHARACTERISTICS

Impedance		NA	Ω
Frequency		NA	GHz
VSWR	NA +	0.000	x F(GHz) Maxi
Insertion loss		NA	\sqrt{F} (GHz) dB Maxi
RF leakage	- (NA	- F(GHz)) dB Maxi
Voltage rating		NA	Veff Maxi
Dielectric withstanding voltage		NA	Veff mini
Insulation resistance		NA	M Ω mini

ENVIRONMENTAL

Operating temperature	-65/+165	$^{\circ}$ C
Hermetic seal	NA	Atm.cm3/s
Panel leakage	NA	

OTHERS CHARACTERISTICS

Assembly instruction

Others :

MECHANICAL CHARACTERISTICS

Center contact retention			
Axial force – Mating end	NA	N	mini
Axial force – Opposite end	NA	N	mini
Torque	NA	N.cm	mini
Recommended torque			
Mating	NA	N.cm	
Panel nut	NA	N.cm	
Mating life	500	Cycles	mini
Weight	8.000	g	

Issue : 0314 K

In the effort to improve our products, we reserve the right to make changes judged to be necessary.

