

DESCRIPTION

The TBMA is a test board for the MagAlpha magnetic position sensor family. The TBMA allows users to run and test MagAlpha sensors quickly. TBMA boards come in two different formats: round (RD) and long (LT). In the RD format, the sensor is mounted in an end-of-shaft configuration. In the LT format, the sensor is mounted on the edge of the board and can be used in both side-shaft and end-of-shaft configurations.

The TBMA is compatible with the Macom kit, offering seamless connection and operation of the MagAlpha and allowing users to evaluate MagAlpha functionalities and performances with their own set-up.

Contrary to the EVMA, the TBMA test board only includes the assembled board with the sensor and decoupling capacitors. It does not include connectors.

FEATURES

- Round Board Format for End-of-Shaft Mounting
- Long Board Format for Side Shaft and End-of-Shaft Mounting
- Compatible with MagAlpha Communication Interface Kit (EVKT-MACOM)

APPLICATIONS

- Servo Drives
- Robotics
- Automotive
- BLDC Motor Commutation
- Encoders

All MPS parts are lead-free, halogen-free, and adhere to the RoHS directive. For MPS green status, please visit the MPS website under Quality Assurance. "MPS" and "The Future of Analog IC Technology" are registered trademarks of Monolithic Power Systems, Inc.

OVERVIEW

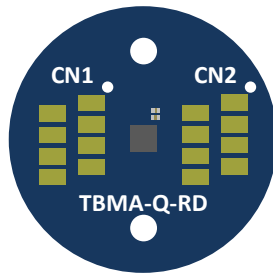

Round (RD)



Long (LT)

Figure 1: TBMA

BOARD TYPE

Different board types are available, and each has a different schematic and layout design (see Table 1). The board type to use is determined by the selected sensor part number.

Each board type is also available in two different formats: a round shape test board (RD), or a long shape test board (LT). The board part number specifies which format is used:

- TBMAXXX-Q-RD-XXX = round shape test board
- TBMAXXX-Q-LT-XXX = long shape test board

Both RD and LT board formats can be used for end-of-shaft configurations where the sensor is positioned at the end of the motor or knob shaft. For side-shaft configurations where the sensor is positioned perpendicularly to the motor or knob shaft, only the RD board format can be used.

Table 1: Board Type

Board Type	Board Part Number	MPS Chip Part Number
Board type 1	TBMA100-Q-RD-00A	MA100
	TBMA100-Q-LT-00A	
	TBMA300-Q-RD-00A	MA300
	TBMA300-Q-LT-00A	
	TBMA700-Q-RD-00A	MA700
	TBMA700-Q-LT-00A	
	TBMA750-Q-RD-00A	MA750
	TBMA750-Q-LT-00A	
<p>NOTE: Availability of this option depends of the chip part ID. Please refer to the part datasheet directly.</p> <p>Board type 2</p> <p>NOTE: Availability of this option depends of the chip part ID. Please refer to the part datasheet directly.</p>	TBMA102-Q-RD-01A	MA102
	TBMA102-Q-LT-01A	
	TBMA302-Q-RD-01A	MA302
	TBMA302-Q-LT-01A	
	TBMA310-Q-RD-01A	MA310
	TBMA310-Q-LT-01A	
	TBMA702-Q-RD-01A	MA702
	TBMA702-Q-LT-01A	
	TBMA710-Q-RD-01A	MA710
	TBMA710-Q-LT-01A	
	TBMA730-Q-RD-01A	MA730
	TBMA730-Q-LT-01A	
	TBMA800-Q-RD-01A	MA800
	TBMA800-Q-LT-01A	
	TBMA820-Q-RD-01A	MA820
	TBMA820-Q-LT-01A	
TBMA850-Q-RD-01A	MA850	
TBMA850-Q-LT-01A		

TBMA CONTENT

Figure 2 shows a list of TBMA test board contents.

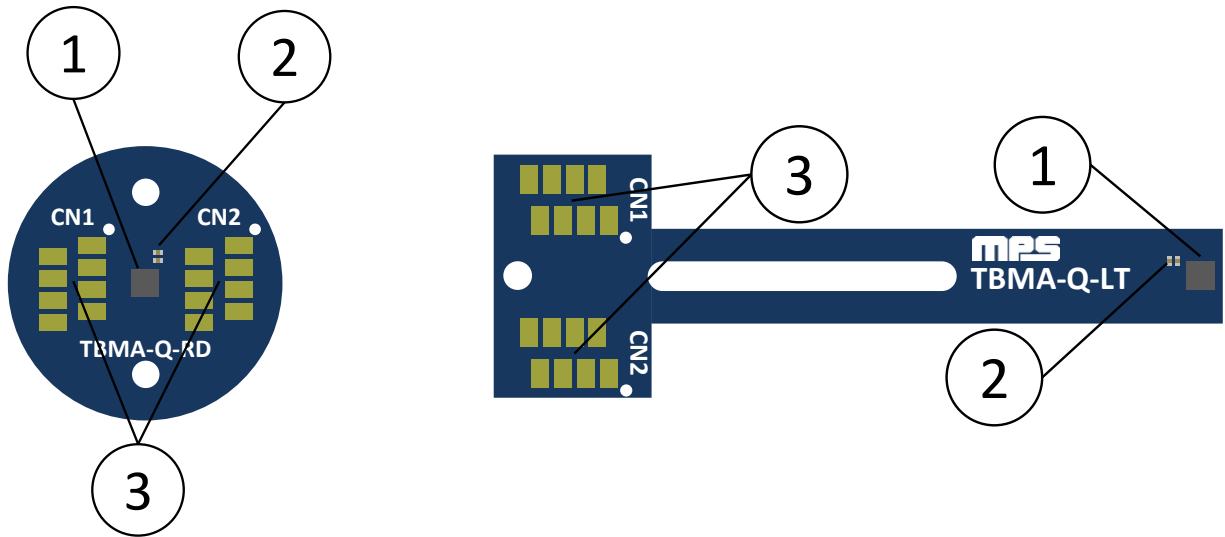

Figure 2: Kit Contents

1. One TBMA board with MagAlpha mounted (RD or LT)
2. Decoupling capacitors
3. Connector footprints (connectors not included)

BOARD TYPE 1

RD Format Overview

Figure 3 shows an overview of the Type 1 round (RD) board type.

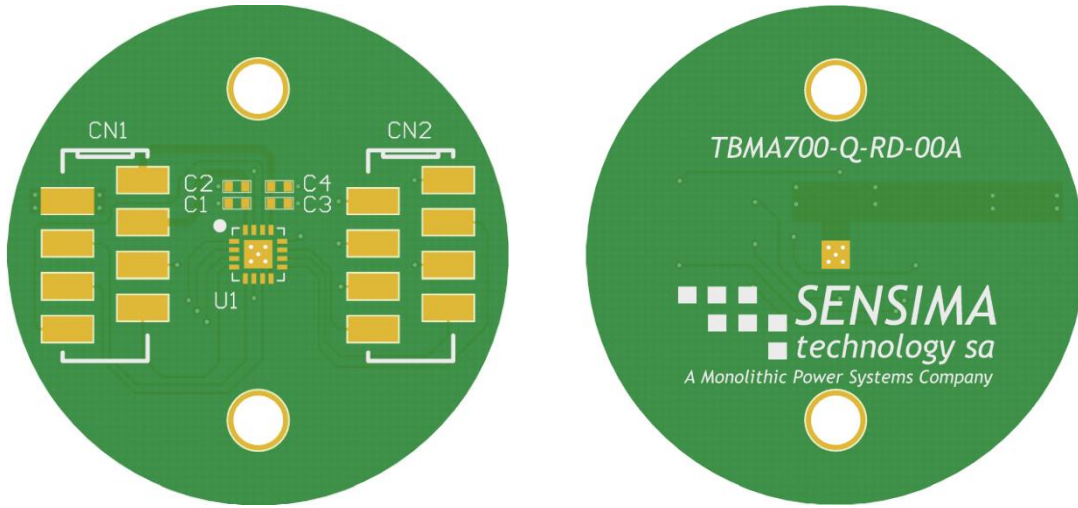

Figure 3: RD Board Overview Type 1

LT Format Overview

Figure 4 shows an overview of the Type 1 long (LT) board type.



Figure 4: LT Board Overview Type 1

Schematic

Figure 5 shows a schematic for the Type 1 board.

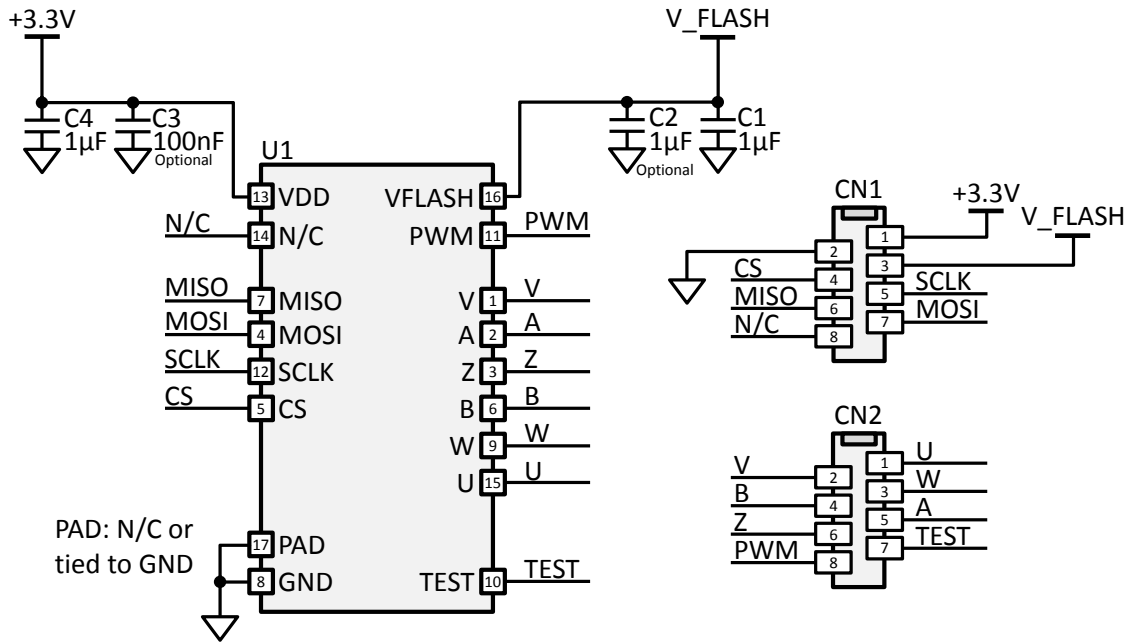

Figure 5: Schematic Type 1

Bill of Materials

The Type 1 board bill of materials (BOM) is shown in Table 2.

Table 2: Bill of Materials Type 1

Quantity	Designator	Description	Value	Manufacturer	Manufacturer PN
2	C1, C4	Ceramic Capacitor; 10V; X6S; 0402	1 μ F	Murata	GRM155C81A105KA12D
1	C2 (optional)	Ceramic Capacitor; 10V; X6S; 0402	1 μ F	Murata	GRM155C81A105KA12D
1	C3 (optional)	Ceramic Capacitor; 16V; X7R; 0402	100nF	Murata	GRM155R71C104KA88J
1	U1	MagAlpha Magnetic Position Sensor	MAxxx	MPS	
2	CN1, CN2 (not populated)	8 Position Receptacle Connector 0.100" (2.54mm), Surface Mount Tin		Würth Elektronik or TE Connectivity	690367280876 or 7-2178711-8

Assembly View

Figure 6 shows the top side assembly view of the Type 1 round board. Figure 7 shows the top side assembly view of the Type 1 long board.

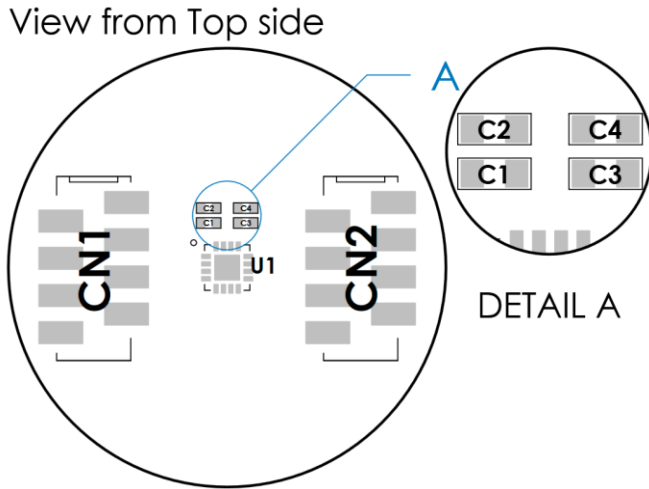

Figure 6: Assembly View RD Type 1

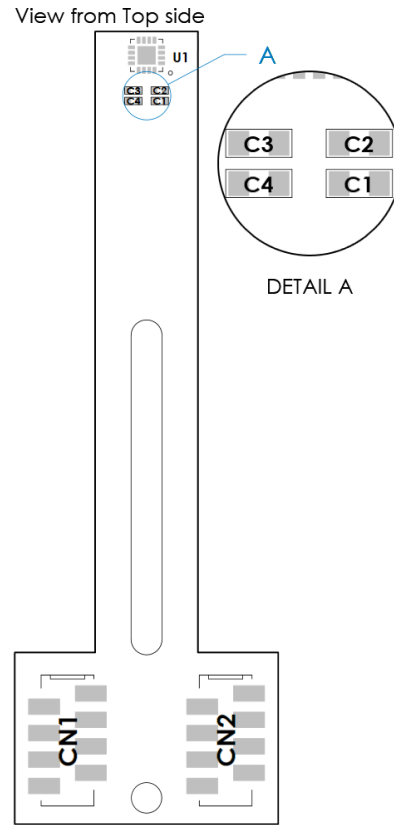

Figure 7: Assembly View LT Type 1

Mechanical Drawing

Figure 8 shows the top side mechanical drawing of the round board. Figure 9 shows the top side mechanical view of the long board.

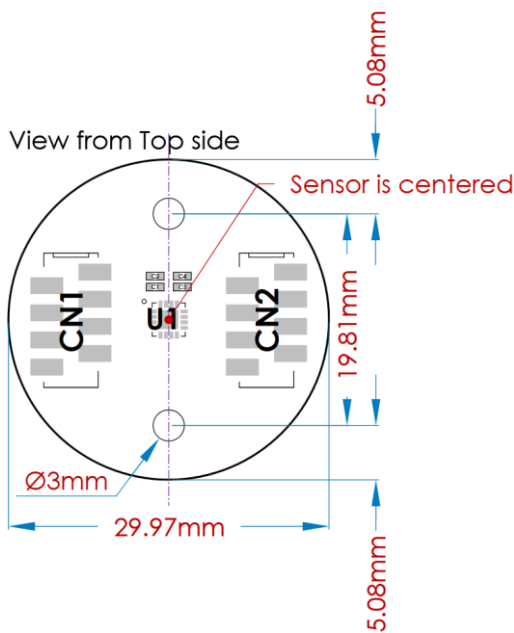
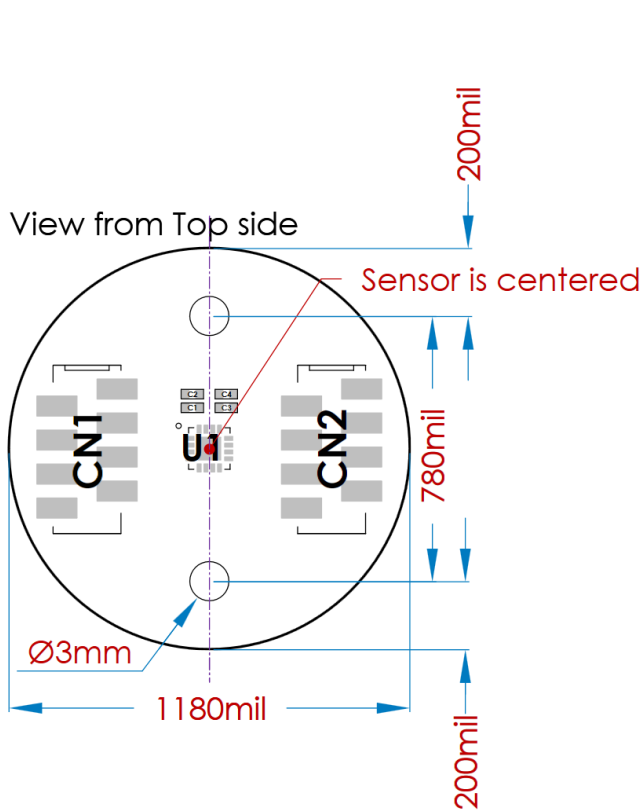

Figure 8: Mechanical Drawing RD Type 1

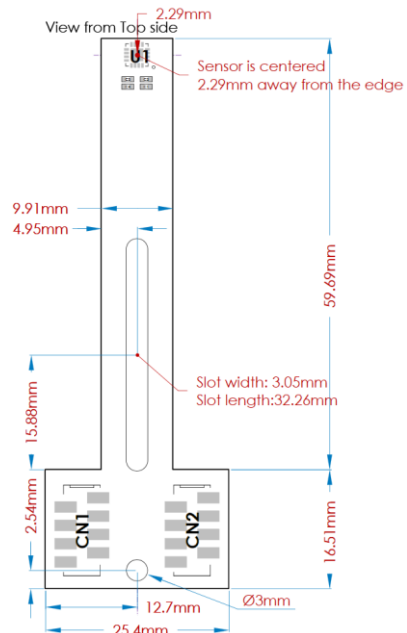
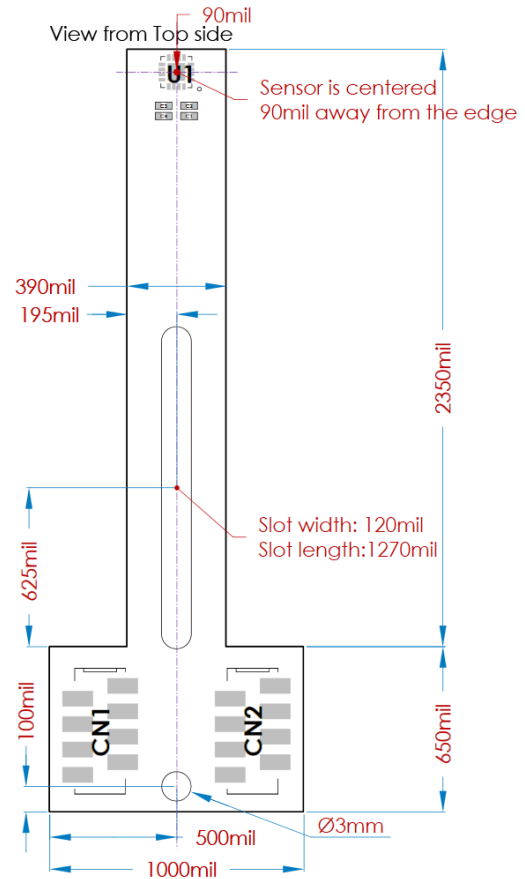
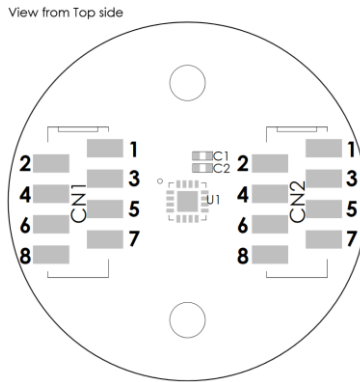
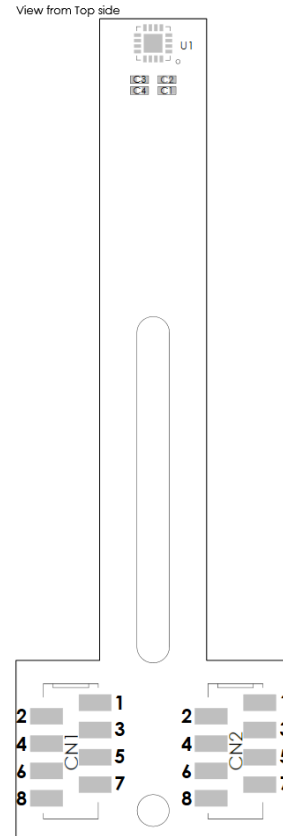

Figure 9: Mechanical Drawing LT Type 1
 mil = 0.001in = 0.0254mm

Connector Pinout

Figure 10 shows the connector pinout of the Type 1 round board. Figure 11 shows the connector pinout for the Type 1 long board.

Figure 10: Connector RD Pinout Type 1

Figure 11: Connector LT Pinout Type 1

See Table 3 for Type 1 pin registers.

Table 3: Connector Pin Mapping Type 1

Pin	Name	Description
CN1.1	VDD	3.3V supply.
CN1.2	GND	Ground.
CN1.3	VFLASH	Flash power supply (3.9V only powered during flashing).
CN1.4	CS	Chip select (serial).
CN1.5	SCLK	Clock (serial).
CN1.6	MISO	Master in slave out (serial).
CN1.7	MOSI	Master out slave in (serial).
CN1.8	-	Leave unconnected.
CN2.1	U ⁽¹⁾	U output (optional motor commutation).
CN2.2	V ⁽¹⁾	V output (optional motor commutation).
CN2.3	W ⁽¹⁾	W output (optional motor commutation).
CN2.4	A ⁽¹⁾	A output (optional incremental encoder).
CN2.5	B ⁽¹⁾	B output (optional incremental encoder).
CN2.6	Z ⁽¹⁾	Z output (optional incremental encoder).
CN2.7	TEST	Test pin.
CN2.8	PWM ⁽¹⁾	Pulse width modulation output (optional).

NOTE:

1) Availability of this option depends of the chip part ID. Please refer to the part datasheet directly.

BOARD TYPE 2

RD Format Overview

Figure 12 shows an overview of the Type 2 round (RD) board type.

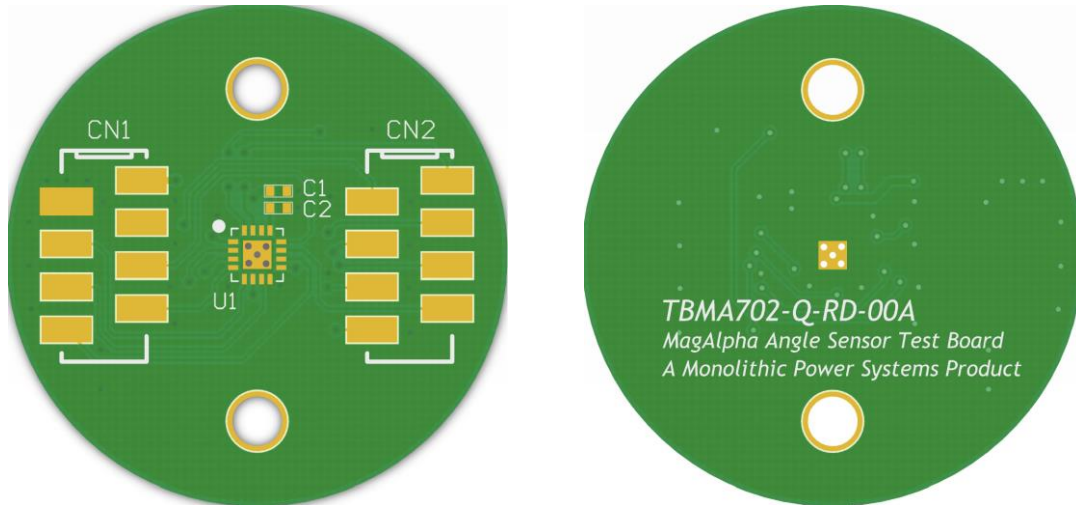

Figure 12: RD Board Overview Type 2

LT Format Overview

Figure 13 shows an overview of the Type 2 long (LT) board type.



Figure 13: LT Board Overview Type 2

Schematic

Figure 14 shows a schematic for the Type 2 board.

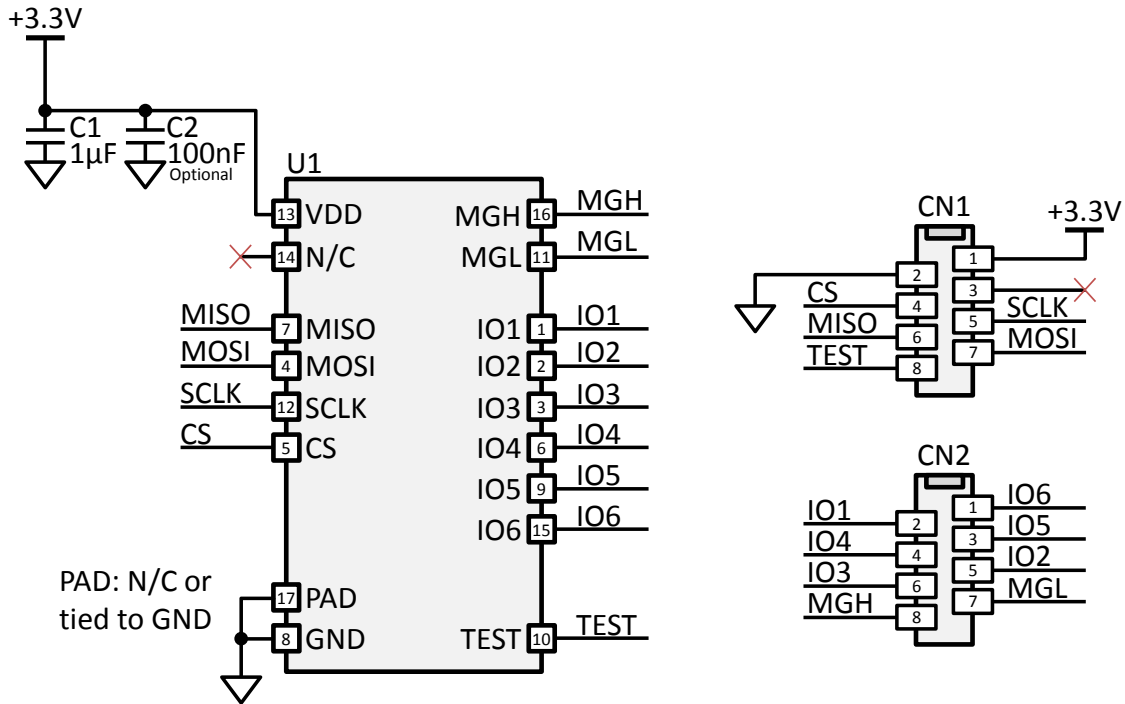

Figure 14: Schematic RD/LT Type 2

Bill of Materials

The Type 2 board bill of materials (BOM) is shown in Table 4.

Table 4: Bill of Materials Type 2

Quantity	Designator	Description	Value	Manufacturer	Manufacturer PN
1	C1	Ceramic Capacitor; 10V; X6S; 0402	1µF	Murata	GRM155C81A105KA12D
1	C2 (not populated)	Ceramic capacitor; 16V; X7R; 0402	100nF	Murata	GRM155R71C104KA88J
1	U1	MagAlpha Magnetic Position Sensor	MAxxx	MPS	
2	CN1, CN2 (not populated)	8 Position Receptacle Connector 0.100" (2.54mm), Surface Mount Tin		Würth Elektronik or TE Connectivity	690367280876 or 7-2178711-8

Assembly View

Figure 15 shows the top side assembly view of the Type 2 round board. Figure 16 shows the top side assembly view of the Type 2 long board.

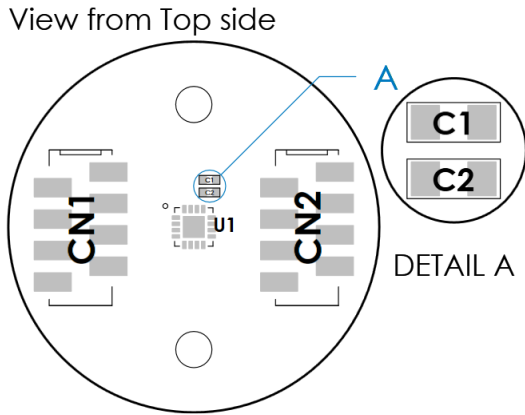

Figure 15: Assembly View RD Type 2

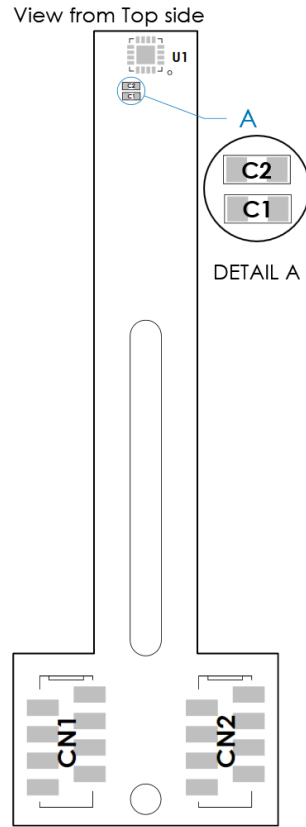

Figure 16: Assembly View LT Type 2

Mechanical Drawing

Figure 17 shows the top side mechanical drawing of the Type 2 round board. Figure 18 shows the top side mechanical view of the Type 2 long board.

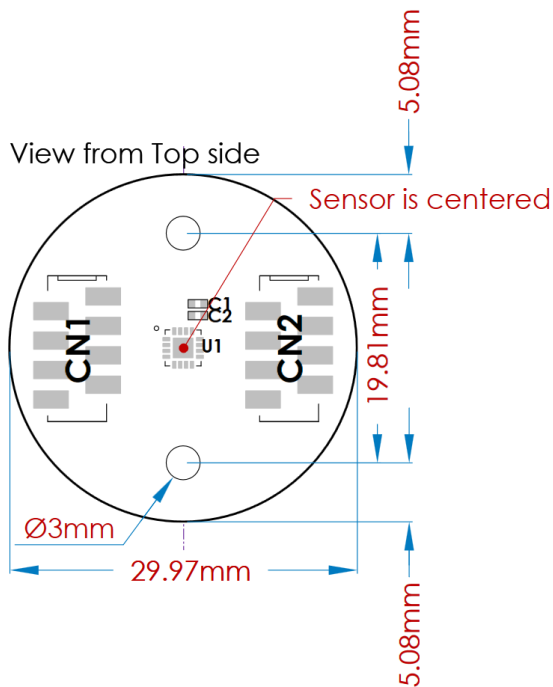
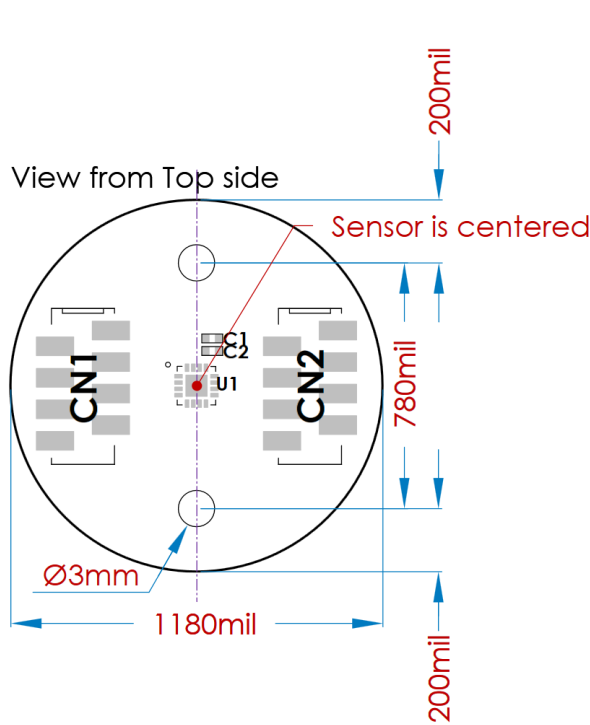
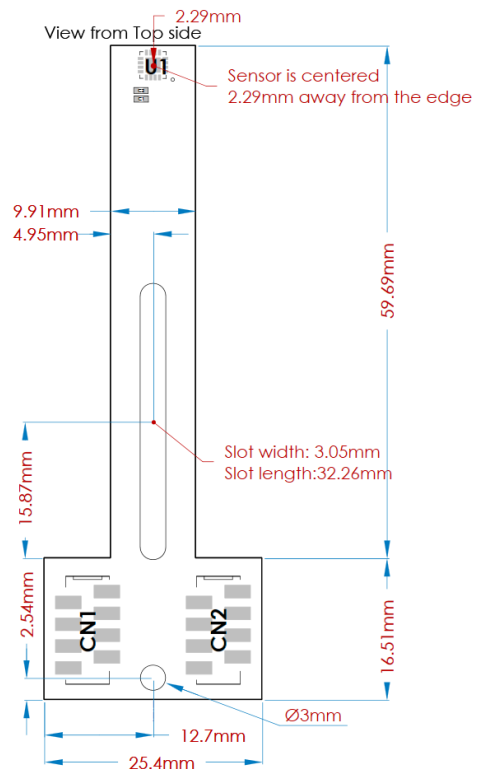
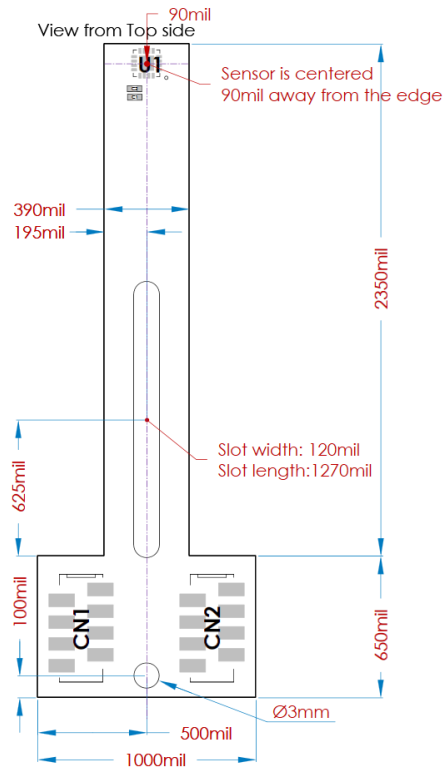

Figure 17: Mechanical Drawing RD Type 2



**Figure 18: Mechanical Drawing LT Type 2
mil = 0.001in = 0.0254mm**

Connector Pinout

Figure 19 shows the connector pinout of the Type 2 round board. Figure 20 shows the connector pinout for the Type 2 long board.

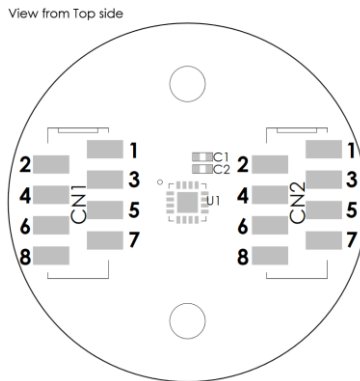
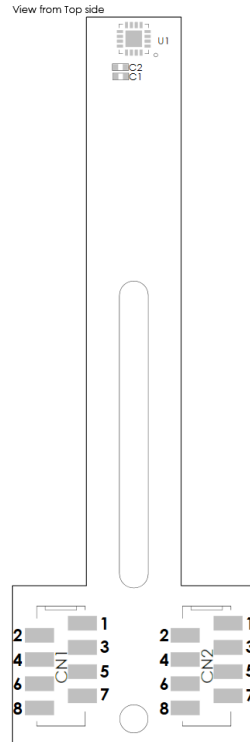
Figure 19: Connector RD Pinout Type 2

Figure 20: Connector LT Pinout Type 2

See Table 5 for Type 2 pin registers.

Table 5: Connector Pin Mapping Type 2

Pin	Name	Description
CN1.1	VDD	3.3V supply.
CN1.2	GND	Ground.
CN1.3	-	-
CN1.4	CS	Chip select (serial).
CN1.5	SCLK	Clock (serial).
CN1.6	MISO	Master in slave out (serial).
CN1.7	MOSI	Master out slave in (serial).
CN1.8	TEST	Test pin.
CN2.1	IO6 ⁽²⁾	Pin 15 (IO).
CN2.2	IO1 ⁽²⁾	Pin 1 (IO).
CN2.3	IO5 ⁽²⁾	Pin 9 (IO).
CN2.4	IO4 ⁽²⁾	Pin 6 (IO).
CN2.5	IO2 ⁽²⁾	Pin 2 (IO).
CN2.6	IO3 ⁽²⁾	Pin 3 (IO).
CN2.7	MGL ⁽³⁾	Magnetic level low (optional).
CN2.8	MGH ⁽³⁾	Magnetic level high (optional).

NOTES:

- 2) Please, refer directly to the chip datasheet to know which features are available on these pins.
- 3) Availability of this option depends of the chip part ID. Please refer to the part datasheet directly.

MAGNET SUPPLIERS

Table 6 shows a non-exhaustive list of possible magnet suppliers. The magnetization direction must be chosen wisely given the fact that most sold magnets are often axially magnetized, which is not a magnetization direction usually required in magnetic angle sensing applications. Angle sensing applications typically use diametrically magnetized magnets.

Table 6: Magnet Suppliers

Company	Website	Address
Maurer Magnetics AG	www.maurermagnetic.ch	Industriestrasse 8 8627 Grüningen Switzerland
Arnold Technologies AG	www.arnoldmagnetics.com	Hübelacherstrasse 15 5242 Birr-Lupfig Switzerland
Bomatec AG	www.bomatec.com	Hofstrasse 1 8181 Höri Switzerland
Dexter Magnetic Technologies	www.dextermag.com	1050 Morse Avenue Elk Grove Village, IL 60007-5110 USA
JPMF	www.jpmp.com.cn	8 LongWan Road Jiangmen City GuangDong Province China
Binicmagnet	www.binicmagnet.com	Unit 612 Yuanzhong Building No. 1905 Hongmei Road Shanghai P. R. China 200233
China Rare Earth Magnet	www.permanentmagnet.com	Room 705, Tower A Century Holiday Plaza 9030 Shennan Rd Nanshan District Shenzhen China
Goudsmit Magnetic Systems	www.goudsmit-magnetics.nl	Petunialaan 19 5582 HA Waalre Netherlands

Maurer Magnetic

Maurer Magnetic has a selection of diametrically magnetized magnets well-suited for contactless rotary angle applications (see Figure 21 and Figure 22). Samples of the types mentioned below should always be available with no lead time.

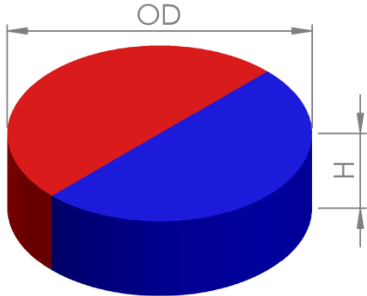

Figure 21: Cylinder Magnet, Diametrically Magnetized

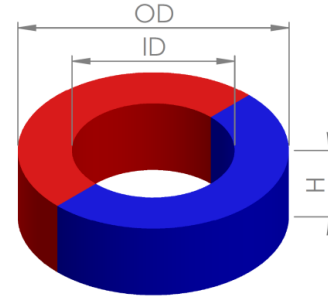

Figure 22: Ring Magnet, Diametrically Magnetized

See Table 7 for a list of Maurer Magnetic magnets.

Table 7: Maurer Magnetic Diametrically Magnetized Magnets

OD (mm)	ID (mm)	H (mm)	Material	Remanence (Br) (T)	Magnetization	Part Number
4.0	-	3.0	N35	1.2	Diametrical	M610403
4.0	-	3.0	Sm26/16-17	1.08	Diametrical	M410403
5.0	-	2.5	N35	1.2	Diametrical	M610502
5.0	-	2.5	Sm26/16-17	1.08	Diametrical	M410502
5.0	1.25	2.5	N35	1.2	Diametrical	M610512
5.0	1.25	2.5	Sm26/16-17	1.08	Diametrical	M410512
6.0	-	2.5	N35	1.2	Diametrical	M610602
6.0	-	2.5	Sm26/16-17	1.08	Diametrical	M410602
6.0	1.5	2.5	N35	1.2	Diametrical	M610612
6.0	1.5	2.5	Sm26/16-17	1.08	Diametrical	M410612
6.0	1.5	3.0	N35	1.2	Diametrical	M610613
6.0	1.5	3.0	Sm26/16-17	1.08	Diametrical	M410613
8.0	-	2.5	N35	1.2	Diametrical	M610802
8.0	-	2.5	Sm26/16-17	1.08	Diametrical	M410802

NOTICE: The information in this document is subject to change without notice. Users should warrant and guarantee that third party Intellectual Property rights are not infringed upon when integrating MPS products into any application. MPS will not assume any legal responsibility for any said applications.