



**Switch-disconnector, DMM, 125 A, 4 pole, Stop Function optional, Without rotary handle and drive shaft, Vertical connection**

**Part no. DMM-125/4-SK**  
**Catalog No. 1314204**

### Delivery program

Product range			Switch-disconnector Main switch maintenance switch										
Part group reference			DMM										
Stop Function			optional										
			Without rotary handle and drive shaft										
Information about equipment supplied			auxiliary contact fitted by user.										
Number of poles			4 pole										
<b>Auxiliary contacts</b>													
		N/O	0										
		N/C	0										
Degree of Protection			IP20										
Design			surface mounting										
Contact sequence			<table border="1" style="margin-left: auto; margin-right: auto;"> <tr> <td>I</td> <td>⊗</td> <td>⊗</td> <td>⊗</td> <td>⊗</td> </tr> <tr> <td>0</td> <td>⊗</td> <td>⊗</td> <td>⊗</td> <td>⊗</td> </tr> </table>	I	⊗	⊗	⊗	⊗	0	⊗	⊗	⊗	⊗
I	⊗	⊗	⊗	⊗									
0	⊗	⊗	⊗	⊗									
<b>Motor rating AC-23A, 50 - 60 Hz</b>													
400 V	P	kW	59										
Rated uninterrupted current	$I_u$	A	125										
Note on rated uninterrupted current $I_u$			Rated uninterrupted current $I_u$ is specified for max. cross-section.										
Connection technique			Vertical connection										

### Technical data

<b>General</b>			
Standards			IEC/EN 60947, VDE 0660, IEC/EN 60204 Switch-disconnector according to IEC/EN 60947-3
Certifications			CE, RoHs, KEMA, EAC, Lloyds
Ambient temperature			
Operation	$\theta$	°C	-25 - +55
Storage	$\theta$	°C	-30 - +80
Overtoltage category/pollution degree			III/3
Rated impulse withstand voltage	$U_{imp}$	kV	6
Rated insulation voltage	$U_i$	V	1000
Mounting position			As required

## Contacts

Mechanical variables			
Number of poles			4 pole
Auxiliary contacts			
		N/O	0
		N/C	0
Electrical characteristics			
Rated operational voltage	$U_e$	V AC	690
Rated uninterrupted current	$I_u$	A	125
Note on rated uninterrupted current $I_u$			Rated uninterrupted current $I_u$ is specified for max. cross-section.
Short-circuit rating			
fuse			125
Rated conditional short-circuit current	$I_q$	kA	50
Breaking current		kA	14.5
max. let-through energy		$kA^2s$	140
Rated short-time withstand current (1 s current)	$I_{cw}$	$A_{rms}$	2500
Note on rated short-time withstand current $I_{cw}$			Current for a time of 1 second
Heat dissipation per pole, current-dependent	$P_{vid}$	W	4.5

## Switching capacity

Rated breaking capacity $\cos \varphi$ to IEC 60947-3		A	
400/415 V		A	480
500 V		A	520
690 V		A	352
Safe isolation to EN 61140			
Current heat loss per contact at $I_e$		W	4.5
Lifespan, mechanical	Operations		10000
AC			
AC-21A			
Rated operational current switch			
400 V 415 V	$I_e$	A	125
500 V	$I_e$	A	125
690 V	$I_e$	A	125
AC-22A			
Rated operational current switch			
400 V 415 V	$I_e$	A	125
500 V	$I_e$	A	125
690 V	$I_e$	A	125
AC-23A			
Rated operational current switch			
400 V 415 V	$I_e$	A	125
500 V	$I_e$	A	66
690 V	$I_e$	A	42
Motor rating AC-23A, 50 - 60 Hz			
400 V 415 V	P	kW	59
500 V	P	kW	45
690 V	P	kW	37

## Terminal capacities

Flexible with ferrules to DIN 46228		$mm^2$	
flexible		$mm^2$	6 - 70
Stripping length		mm	21
Tightening torque for terminal screw		Nm	7

## Technical safety parameters:

<b>Notes</b>			B10 <sub>d</sub> values as per EN ISO 13849-1, table C1
--------------	--	--	---

## Design verification as per IEC/EN 61439

Technical data for design verification			
Rated operational current for specified heat dissipation	$I_n$	A	125
Heat dissipation per pole, current-dependent	$P_{vid}$	W	4.5
Equipment heat dissipation, current-dependent	$P_{vid}$	W	0
Static heat dissipation, non-current-dependent	$P_{vs}$	W	0
Heat dissipation capacity	$P_{diss}$	W	0
Operating ambient temperature min.		°C	-25
Operating ambient temperature max.		°C	55
IEC/EN 61439 design verification			
10.2 Strength of materials and parts			
10.2.2 Corrosion resistance			
			Meets the product standard's requirements.
10.2.3.1 Verification of thermal stability of enclosures			
			Meets the product standard's requirements.
10.2.3.2 Verification of resistance of insulating materials to normal heat			
			Meets the product standard's requirements.
10.2.3.3 Verification of resistance of insulating materials to abnormal heat and fire due to internal electric effects			
			Meets the product standard's requirements.
10.2.4 Resistance to ultra-violet (UV) radiation			
			Meets the product standard's requirements.
10.2.5 Lifting			
			Does not apply, since the entire switchgear needs to be evaluated.
10.2.6 Mechanical impact			
			Does not apply, since the entire switchgear needs to be evaluated.
10.2.7 Inscriptions			
			Meets the product standard's requirements.
10.3 Degree of protection of ASSEMBLIES			
			Does not apply, since the entire switchgear needs to be evaluated.
10.4 Clearances and creepage distances			
			Meets the product standard's requirements.
10.5 Protection against electric shock			
			Does not apply, since the entire switchgear needs to be evaluated.
10.6 Incorporation of switching devices and components			
			Does not apply, since the entire switchgear needs to be evaluated.
10.7 Internal electrical circuits and connections			
			Is the panel builder's responsibility.
10.8 Connections for external conductors			
			Is the panel builder's responsibility.
10.9 Insulation properties			
10.9.2 Power-frequency electric strength			
			Is the panel builder's responsibility.
10.9.3 Impulse withstand voltage			
			Is the panel builder's responsibility.
10.9.4 Testing of enclosures made of insulating material			
			Is the panel builder's responsibility.
10.10 Temperature rise			
			The panel builder is responsible for the temperature rise calculation. Eaton will provide heat dissipation data for the devices.
10.11 Short-circuit rating			
			Is the panel builder's responsibility. The specifications for the switchgear must be observed.
10.12 Electromagnetic compatibility			
			Is the panel builder's responsibility. The specifications for the switchgear must be observed.
10.13 Mechanical function			
			The device meets the requirements, provided the information in the instruction leaflet (IL) is observed.

## Technical data ETIM 7.0

Low-voltage industrial components (EG000017) / Switch disconnecter (EC000216)			
Electric engineering, automation, process control engineering / Low-voltage switch technology / Off-load switch, circuit breaker, control switch / Switch disconnecter (ec@ss10.0.1-27-37-14-03 [AKF060013])			
Version as main switch			Yes
Version as maintenance-/service switch			Yes
Version as safety switch			No
Version as emergency stop installation			No
Version as reversing switch			No
Number of switches			1
Max. rated operation voltage $U_e$ AC		V	690
Rated operating voltage		V	690 - 690
Rated permanent current $I_u$		A	125
Rated permanent current at AC-23, 400 V		A	125
Rated permanent current at AC-21, 400 V		A	125
Rated operation power at AC-3, 400 V		kW	0
Rated short-time withstand current $I_{cw}$		kA	2.5
Rated operation power at AC-23, 400 V		kW	30

Switching power at 400 V	kW	0
Conditioned rated short-circuit current Iq	kA	50
Number of poles		4
Number of auxiliary contacts as normally closed contact		0
Number of auxiliary contacts as normally open contact		0
Number of auxiliary contacts as change-over contact		0
Motor drive optional		No
Motor drive integrated		No
Voltage release optional		No
Device construction		Built-in device fixed built-in technique
Suitable for ground mounting		Yes
Suitable for front mounting 4-hole		No
Suitable for front mounting centre		No
Suitable for distribution board installation		No
Suitable for intermediate mounting		No
Colour control element		Other
Type of control element		Other
Interlockable		No
Type of electrical connection of main circuit		Screw connection
Degree of protection (IP), front side		IP20
Degree of protection (NEMA)		Other

## Dimensions

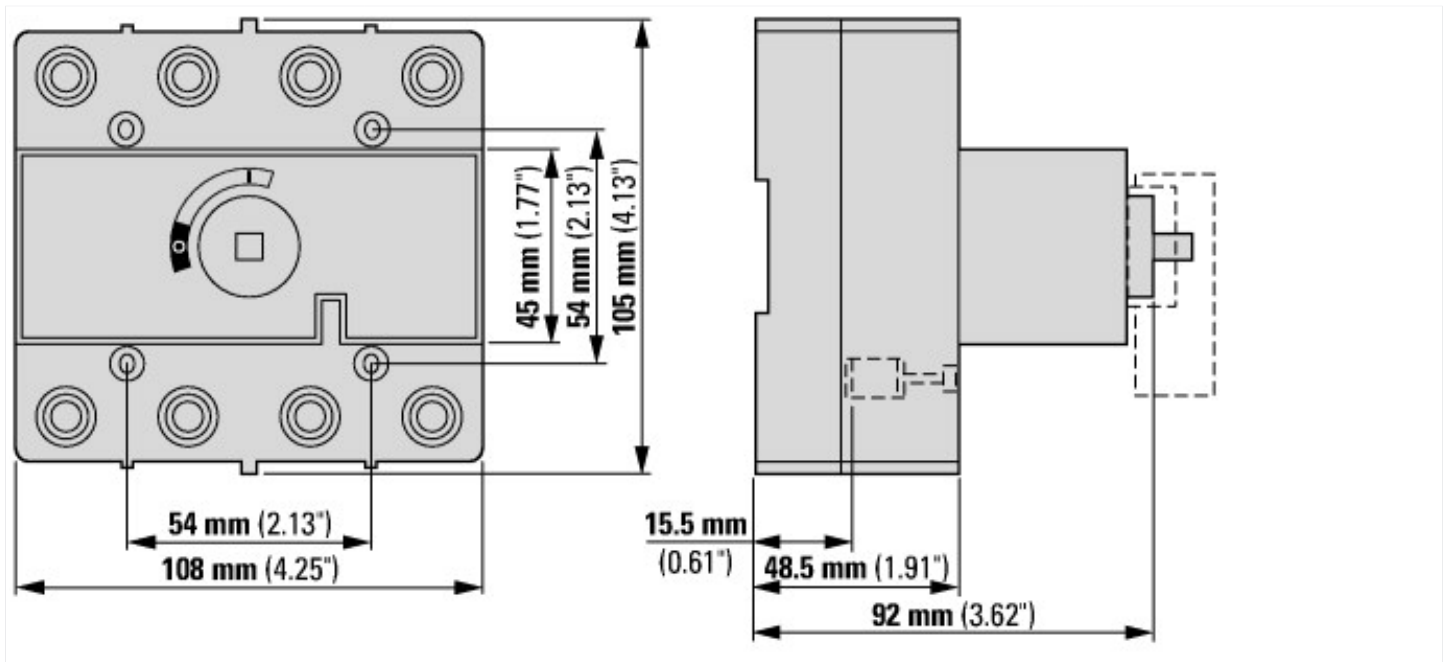

## Additional product information (links)

**IL008025ZU Switch-disconnector DCM, DMM**

IL008025ZU Switch-disconnector DCM, DMM [ftp://ftp.moeller.net/DOCUMENTATION/AWA\\_INSTRUCTIONS/IL008025ZU2020\\_04.pdf](ftp://ftp.moeller.net/DOCUMENTATION/AWA_INSTRUCTIONS/IL008025ZU2020_04.pdf)