



Switch-disconnector, DMM, 160 A, 4 pole, Emergency switching off function, With red rotary handle and yellow locking ring, in CI-K5 enclosure

Part no. DMM-160/4/I5/P-R
Catalog No. 172797

EL-Nummer (Norway) 1405715

Delivery program

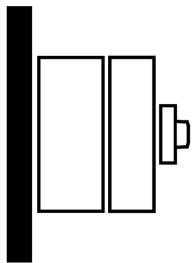
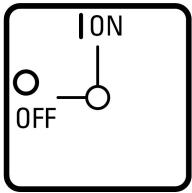
Product range			Switch-disconnector Main switch maintenance switch										
Part group reference			DMM										
Stop Function			Emergency switching off function										
Information about equipment supplied			With red rotary handle and yellow locking ring auxiliary contact fitted by user.										
Notes			in CI-K5 enclosure										
Number of poles			4 pole										
Auxiliary contacts													
		N/O	0										
		N/C	0										
Notes			1 padlock, # 5 mm										
Locking facility			Lockable in the 0 (Off) position										
Degree of Protection			IP65										
			totally insulated										
Design			surface mounting										
													
Contact sequence			<table border="1"> <tr> <td>1</td> <td>X</td> <td>X</td> <td>X</td> <td>X</td> </tr> <tr> <td>0</td> <td></td> <td></td> <td></td> <td></td> </tr> </table> <p>1 0 2 0 3 0 4 0 5 0 6 0 7 0 8 0</p>	1	X	X	X	X	0				
1	X	X	X	X									
0													
Switching angle		°	90										
Function													
Motor rating AC-23A, 50 - 60 Hz													
400 V	P	kW	80										
Rated uninterrupted current	I _u	A	160										
Note on rated uninterrupted current I _u			Rated uninterrupted current I _u is specified for max. cross-section.										

Technical data

General

Standards	IEC/EN 60947, VDE 0660, IEC/EN 60204
-----------	--------------------------------------

Certifications			Switch-disconnector according to IEC/EN 60947-3 CE, RoHs, KEMA, EAC, Lloyds
Ambient temperature			
Operation	θ	°C	-25 - +60
Storage	θ	°C	-40 - +80
Overvoltage category/pollution degree			III/3
Rated impulse withstand voltage	U_{imp}	kV	6
Rated insulation voltage	U_i	V	1000
Mounting position			As required

Contacts

Mechanical variables			
Number of poles			4 pole
Auxiliary contacts			
		N/O	0
		N/C	0
Electrical characteristics			
Rated operational voltage	U_e	V AC	690
Rated uninterrupted current	I_u	A	160
Note on rated uninterrupted current I_u			Rated uninterrupted current I_u is specified for max. cross-section.
Short-circuit rating			
fuse			160
Rated conditional short-circuit current	I_q	kA	415 V: 30 690 V: 50
Breaking current		kA	13.5
max. let-through energy		kA^2s	86,9
Rated short-time withstand current (1 s current)	I_{cw}	A_{rms}	2500
Note on rated short-time withstand current I_{cw}			Current for a time of 1 second
Heat dissipation per pole, current-dependent	P_{vid}	W	7.4

Switching capacity

Rated breaking capacity $\cos \varphi$ to IEC 60947-3		A	
400/415 V		A	1080
500 V		A	528
690 V		A	336
Safe isolation to EN 61140			
Current heat loss per contact at I_e		W	7.4
Lifespan, mechanical	Operations		10000
AC			
AC-21A			
Rated operational current switch			
400 V 415 V	I_e	A	160
500 V	I_e	A	160
690 V	I_e	A	160
AC-22A			
Rated operational current switch			
400 V 415 V	I_e	A	160
500 V	I_e	A	160
690 V	I_e	A	160
AC-23A			
Rated operational current switch			
400 V 415 V	I_e	A	140
500 V	I_e	A	66
690 V	I_e	A	42
Motor rating AC-23A, 50 - 60 Hz	P	kW	
400 V 415 V	P	kW	80
500 V	P	kW	45

690 V	P	kW	37
Terminal capacities			
Flexible with ferrules to DIN 46228		mm ²	
flexible		mm ²	6 - 70
Stripping length		mm	21
Tightening torque for terminal screw		Nm	7
Technical safety parameters:			
Notes			B10 _d values as per EN ISO 13849-1, table C1

Design verification as per IEC/EN 61439

Technical data for design verification			
Rated operational current for specified heat dissipation	I _n	A	160
Heat dissipation per pole, current-dependent	P _{vid}	W	7.4
Equipment heat dissipation, current-dependent	P _{vid}	W	0
Static heat dissipation, non-current-dependent	P _{vs}	W	0
Heat dissipation capacity	P _{diss}	W	0
Operating ambient temperature min.		°C	-25
Operating ambient temperature max.		°C	40
IEC/EN 61439 design verification			
10.2 Strength of materials and parts			
10.2.2 Corrosion resistance			Meets the product standard's requirements.
10.2.3.1 Verification of thermal stability of enclosures			Meets the product standard's requirements.
10.2.3.2 Verification of resistance of insulating materials to normal heat			Meets the product standard's requirements.
10.2.3.3 Verification of resistance of insulating materials to abnormal heat and fire due to internal electric effects			Meets the product standard's requirements.
10.2.4 Resistance to ultra-violet (UV) radiation			UV resistance only in connection with protective shield.
10.2.5 Lifting			Does not apply, since the entire switchgear needs to be evaluated.
10.2.6 Mechanical impact			Does not apply, since the entire switchgear needs to be evaluated.
10.2.7 Inscriptions			Meets the product standard's requirements.
10.3 Degree of protection of ASSEMBLIES			Does not apply, since the entire switchgear needs to be evaluated.
10.4 Clearances and creepage distances			Meets the product standard's requirements.
10.5 Protection against electric shock			Does not apply, since the entire switchgear needs to be evaluated.
10.6 Incorporation of switching devices and components			Does not apply, since the entire switchgear needs to be evaluated.
10.7 Internal electrical circuits and connections			Is the panel builder's responsibility.
10.8 Connections for external conductors			Is the panel builder's responsibility.
10.9 Insulation properties			
10.9.2 Power-frequency electric strength			Is the panel builder's responsibility.
10.9.3 Impulse withstand voltage			Is the panel builder's responsibility.
10.9.4 Testing of enclosures made of insulating material			Is the panel builder's responsibility.
10.10 Temperature rise			The panel builder is responsible for the temperature rise calculation. Eaton will provide heat dissipation data for the devices.
10.11 Short-circuit rating			Is the panel builder's responsibility. The specifications for the switchgear must be observed.
10.12 Electromagnetic compatibility			Is the panel builder's responsibility. The specifications for the switchgear must be observed.
10.13 Mechanical function			The device meets the requirements, provided the information in the instruction leaflet (IL) is observed.

Technical data ETIM 7.0

Low-voltage industrial components (EG000017) / Switch disconnecter (EC000216)			
Electric engineering, automation, process control engineering / Low-voltage switch technology / Off-load switch, circuit breaker, control switch / Switch disconnecter (ecl@ss10.0.1-27-37-14-03 [AKF060013])			
Version as main switch			Yes
Version as maintenance-/service switch			Yes
Version as safety switch			No
Version as emergency stop installation			Yes
Version as reversing switch			No

Number of switches		1
Max. rated operation voltage Ue AC	V	690
Rated operating voltage	V	690 - 690
Rated permanent current Iu	A	160
Rated permanent current at AC-23, 400 V	A	140
Rated permanent current at AC-21, 400 V	A	160
Rated operation power at AC-3, 400 V	kW	0
Rated short-time withstand current Icw	kA	2.5
Rated operation power at AC-23, 400 V	kW	0
Switching power at 400 V	kW	0
Conditioned rated short-circuit current Iq	kA	50
Number of poles		4
Number of auxiliary contacts as normally closed contact		0
Number of auxiliary contacts as normally open contact		0
Number of auxiliary contacts as change-over contact		0
Motor drive optional		No
Motor drive integrated		No
Voltage release optional		No
Device construction		Complete device in housing
Suitable for ground mounting		Yes
Suitable for front mounting 4-hole		No
Suitable for front mounting centre		No
Suitable for distribution board installation		No
Suitable for intermediate mounting		No
Colour control element		Red
Type of control element		Short thumb-grip
Interlockable		Yes
Type of electrical connection of main circuit		Screw connection
Degree of protection (IP), front side		IP65
Degree of protection (NEMA)		Other

Dimensions

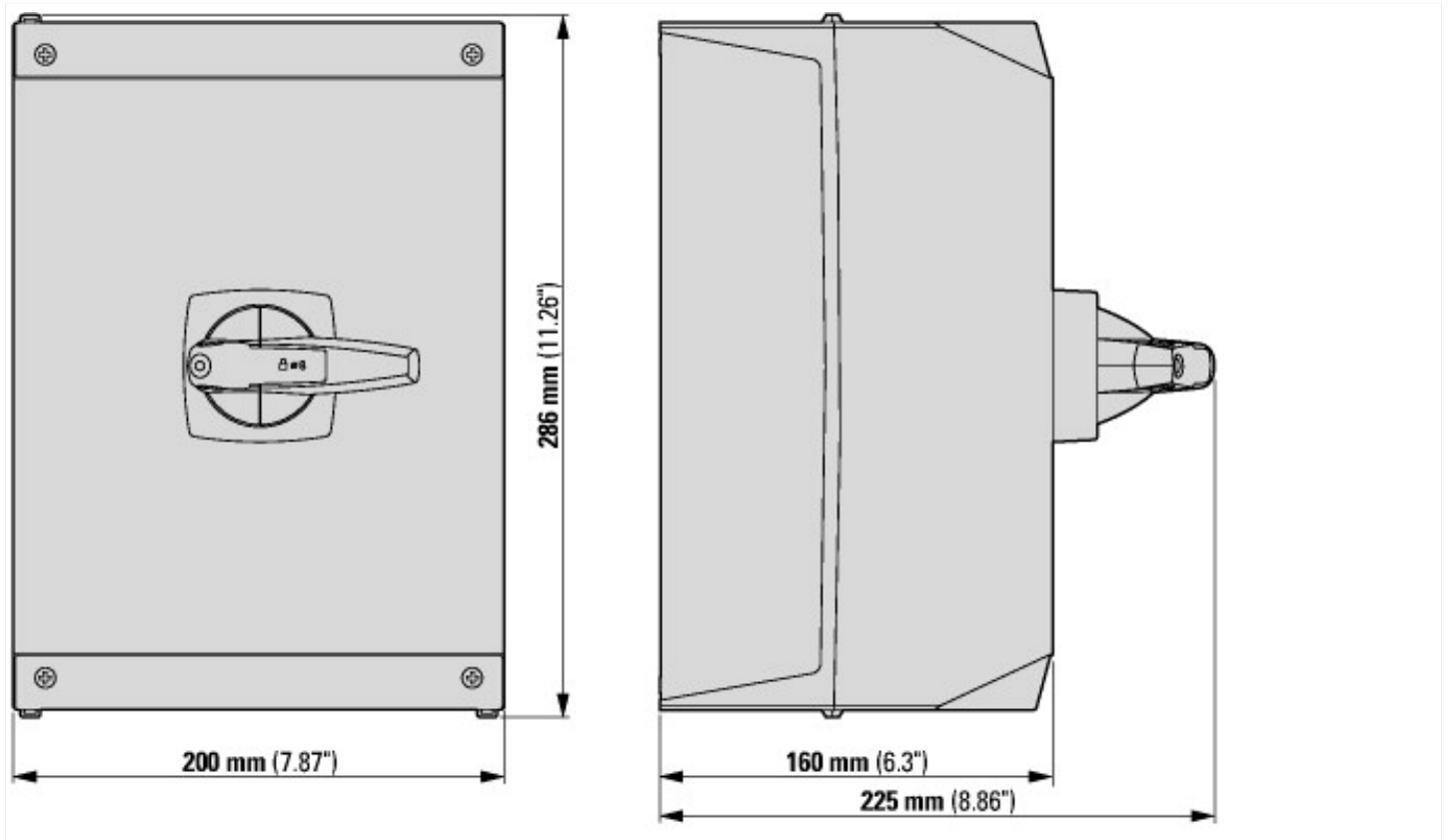

Additional product information (links)

IL008006Z Switch-disconnectors

IL008006Z Switch-disconnectors

ftp://ftp.moeller.net/DOCUMENTATION/AWA_INSTRUCTIONS/IL008006ZU2018_05.pdf