

Small Sensing Head

- Compact sensing head available in a wide variation of designs features installation in a narrow space.
- Mutual interference preventive function allows side-by-side mounting of two sensors.
- Light indicator provided in the sensing head.

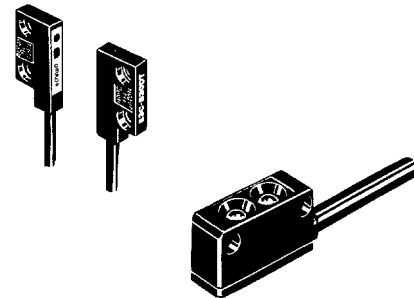

Ordering Information

■ Sensor Units

Through-beam (Separate) Sensors

Model	E3C-S10	E3C-S20W	E3C-S30T	E3C-S30W
Appearance				
Sensing distance	10 cm	20 cm	30 cm	30 cm

Model	E3C-S50	E3C-1	E3C-2	E3C-S5	E3C-S5A
Appearance					
Sensing distance	50 cm	1 m	2 m	5 cm	5 cm

Diffuse Reflective Sensors



Model	E3C-DS5W	E3C-DS10	E3C-DS10T
Appearance			
Sensing distance	5 cm	10 cm	10 cm

Model	E3C-DM2R	E3C-DM5	E3C-DS1	E3C-DM5A	E3C-DS1A
Appearance					
Sensing distance	2 mm	5 mm	1 cm	5 mm	1 cm



Definite Reflective Sensor

Model	E3C-LS3R
Appearance	
Sensing distance	3±0.3 cm

Mark Sensor

Model	E3C-VS1G	E3C-VS3R	E3C-VM35R	E3C-VS7R
Appearance				
Sensing distance	1±0.2 cm	3±0.5 cm	3.5±0.5 cm	7±1 cm

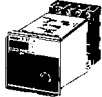
■ Amplifier Units

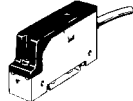
Type		AC operation		DC operation		
		Standard	Multi-function	Slim top	Miniature	Cable connection
Model		E3C-A	E3C-C	E3C-WH4F	E3C-GE4 (NPN output)	E3C-JC4P (NPN output)
Appearance						
Mounting		Surface/DIN track with socket (see note)		DIN track	Surface/DIN track with socket (see note)	DIN track
Output	Relay	Yes	Yes	No	No	No
	Solid-state	Yes	Yes	Yes	Yes	Yes
Timer function		No	Yes (ON/OFF, one-shot delay)	No	No	Yes (OFF-delay)
Gate function		No	Yes	No	No	No

Note: E3C-A and E3C-C include DIN track-mount socket PF113A.

Specifications

■ Ratings/Characteristics

Sensor Units (with E3C Amplifier)

Item	E3C-S10	E3C-S20W	E3C-S50	E3C-30T E3C-30W	E3C-1	E3C-2
	Through-beam					
Sensing distance	10 cm	20 cm	50 cm	30 cm	1 m	2 m
Standard object	2 mm (opaque object)		3 mm (opaque object)	0.3 dia. (opaque object)	4 mm (opaque object)	8 mm (opaque object)
Indicator	Light indicator (red)					
Enclosure ratings	IEC IP64	IEC IP50	IEC IP64	IEC IP60	IEC IP66	IEC IP66
Material	Plastic					Metal
Light source	Infrared LED					
Ambient temperature	Operating: -25°C to 70°C (with no icing)					

Item	E3C-DS5W	E3C-DS10T	E3C-DS10	E3C-LS3R
	Diffuse reflective			Definite reflective
Sensing distance	5 cm	10 cm		3±0.3 cm
Standard object	10 x 10 cm (white mat paper)		5 x 5 cm (white mat paper)	1 x 1 cm (see note)
Indicator	Light indicator (red)			
Enclosure ratings	IEC IP50		IEC IP64	
Material	Plastic			
Light source	Infrared LED			Red LED
Ambient temperature	Operating: -25°C to 70°C (with no icing)			

Item	E3C-S5	E3C-DM2R	E3C-DM5	E3C-DS1	E3C-S5A	E3C-DM5A	E3C-DS1A
	Through-beam	Diffuse reflective			Through-beam	Diffuse reflective	
Sensing distance	5 cm	2 mm	5 mm	1 cm	5 cm	5 mm	1 cm
Standard object	2 mm (opaque object)	1 x 1 cm (see note)		2 x 2 cm (see note)	2 mm (opaque object) (see note)	1 x 1 cm (white mat paper)	2 x 2 cm (see note)
Differential travel	---	20% max.			---	20% max.	
Indicator	Light indicator (red)				---		
Enclosure ratings	IEC IP64						
Material	Plastic						
Ambient temperature	Operating: -25°C to 70°C (with no icing)						

Note: 90% reflection white mat paper

Item	E3C-VS1G	E3C-VS3R	E3C-VM35R	E3C-VS7R
	Retroreflective for mark sensor			
Sensing distance	1±0.2 cm	3±0.5 cm	3.5±0.5 cm	7±1.0 cm
Min. sensing mark width	0.9 mm (center of Sensing distance)	1.6 mm (center of Sensing distance)	0.2 mm (center of Sensing distance)	0.6 mm (center of Sensing distance)
Ambient illumination	Incandescent lamp: 1,000 lx max. Sunlight: 3,000 lx max.			
Ambient temperature	Operating: -10°C to 70°C (with no icing)		Operating: -25°C to 70°C (with no icing)	Operating: -10°C to 70°C (with no icing)
Ambient humidity	Operating: 35% to 85%			
Enclosure ratings	IEC IP64		IEC IP50	
Vibration resistance	Destruction: 10 to 55 Hz, 1.5-mm double amplitude for 2 hrs each in X, Y, and Z directions			
Shock resistance	Destruction: 500 m/s ² (approx. 50G)			

Amplifier Units

Item	E3C-A	E3C-C	E3C-WH4F	E3C-G□4	E3C-J□4P
Power supply voltage	100 to 240 VAC ±10%, 50/60 Hz		12 to 24 VDC ±10%, ripple (p-p): 1 V max.		
Current consumption	3 W max.		50 mA max.		
Output	DC solid-state load	80 mA max.		100 mA max.	
	Relay output	1 A at 220 VAC, cosφ = 1		---	
	DC voltage drop	1 V max.	0.7 V max.	1.2 V max.	0.7 V max.
Alarm output	---				50 mA
Response time	1/2 ms max. selectable				1 ms
Timer function	---	ON/OFF, one-shot delay (selectable): 1 or 10 s max.	---		OFF-delay (selectable): 40 ms
Sensitivity adjustment	Adjustable				
Operation mode	Switch selectable			Wire selectable	Switch selectable
Indicators	Light (red) and stability (green)	Light (red), stability (green) and operation (yellow)	Light (red) and stability (green)		
Mutual interference protection	Provided				
Enclosure rating	IEC IP40 (excluding terminals)				IEC IP50
Material	Plastic				
Ambient temperature	Operating: -10°C to 55°C (with no icing)				

Engineering Data

Excess Gain Ratio

E3C-S20W (Typical)

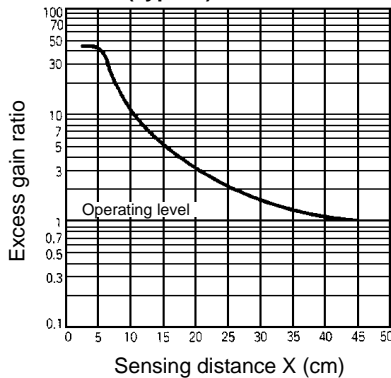

E3C-S30T/S30W (Typical)

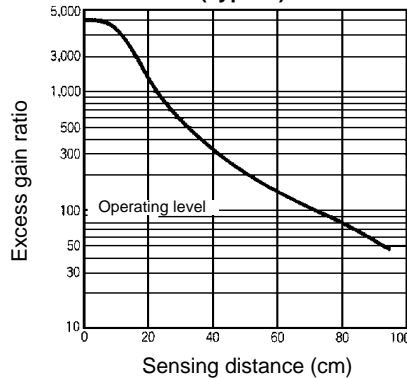

E3C-S50

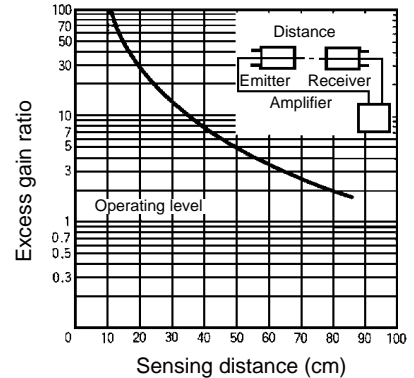

E3C-DS5W (Typical)

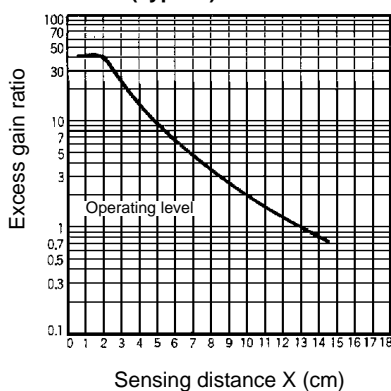

E3C-DS10T (Typical)

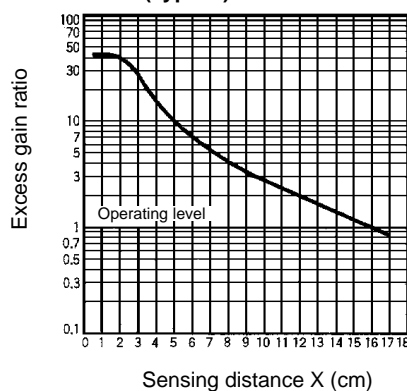

E3C-LS3R

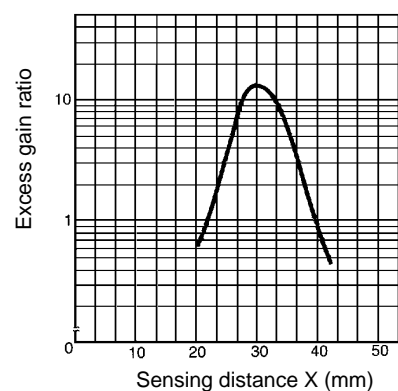

Operating Range

E3C-S10

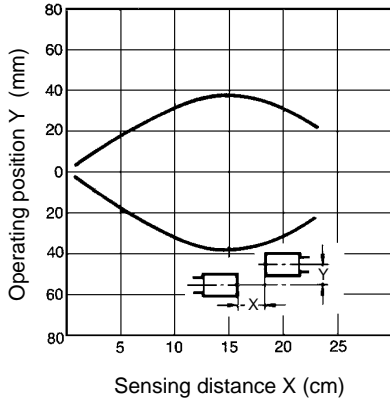

E3C-S20W

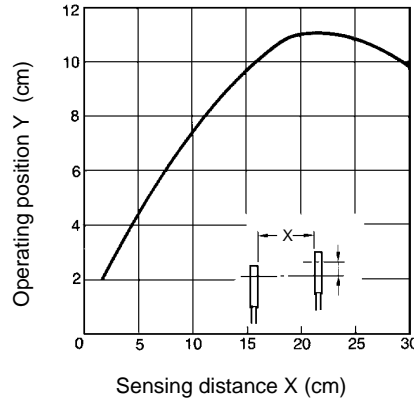

E3C-S30T/S30W (Typical)

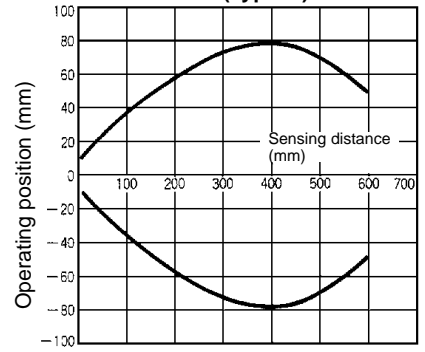

E3C-S50

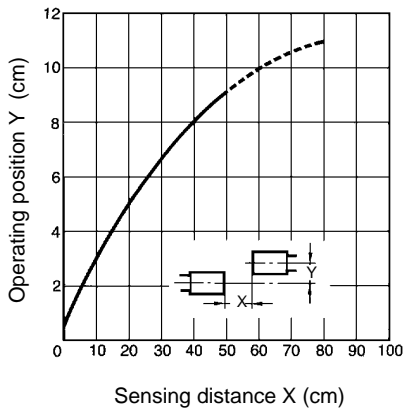

E3C-DS5W

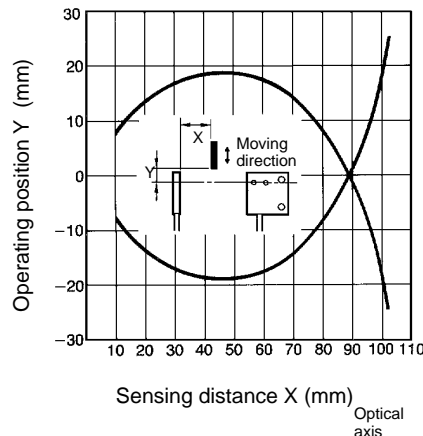

E3C-DS10T (Typical)

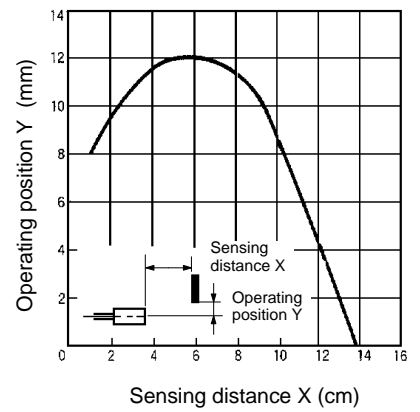

E3C-DS10 (Typical 1)

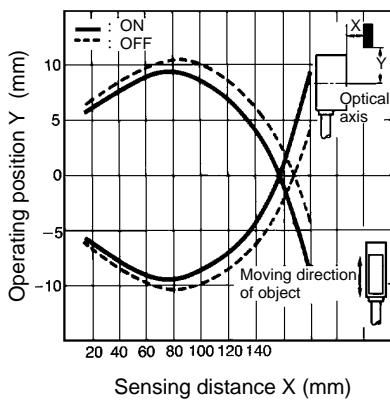

E3C-DS10 (Typical 2)

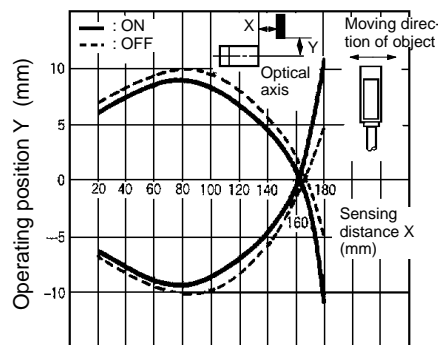

E3C-1

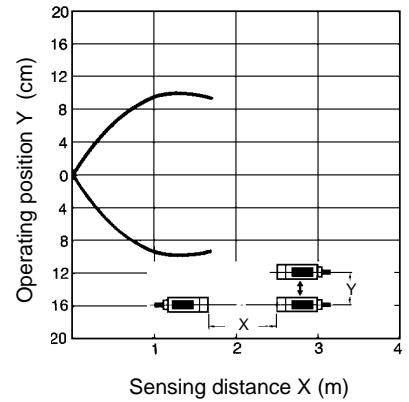

E3C-2

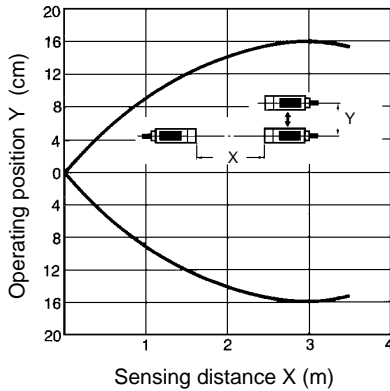

E3C-LS3R (Typical 1)

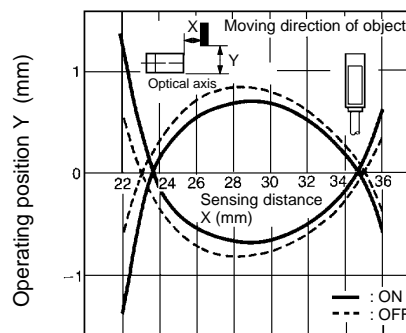

E3C-LS3R (Typical 2)

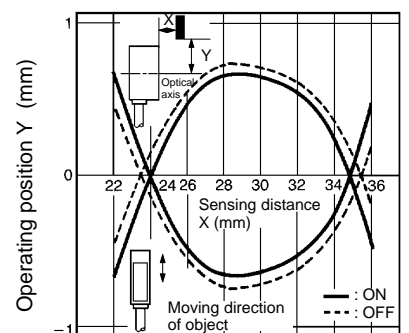

E3C-DM2R (Typical)

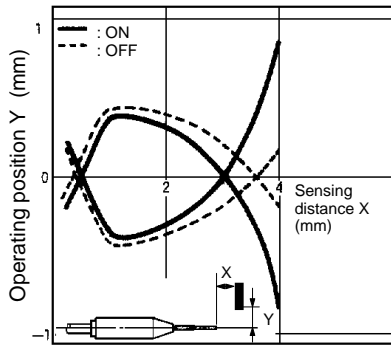

E3C-DM5/-DM5A (Typical)

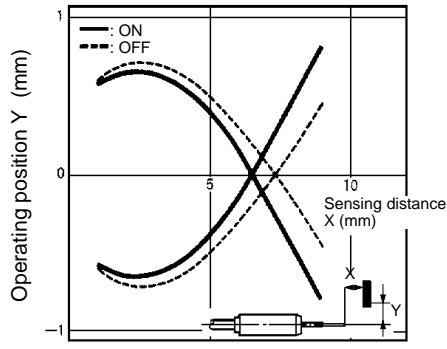

E3C-DS1/-DS1A (Typical)

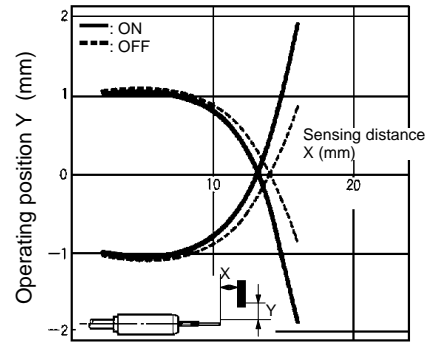

Sensitivity

E3C-DS5W

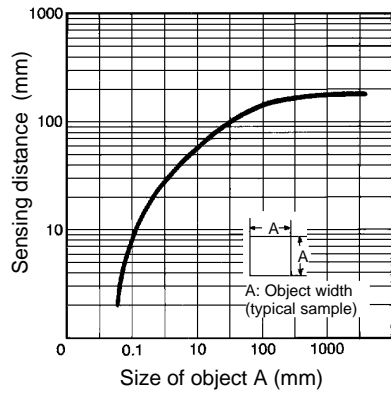

Operation

■ Amplifier Units Output Circuits

E3C-A/E3C-C

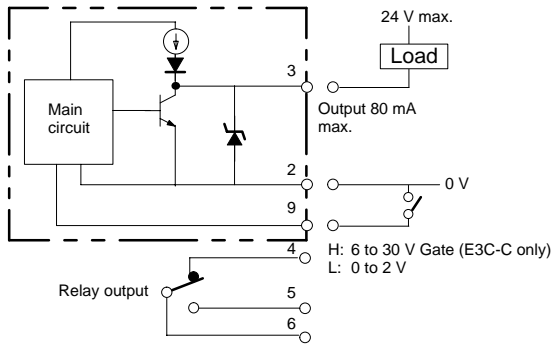

E3C-WH4F

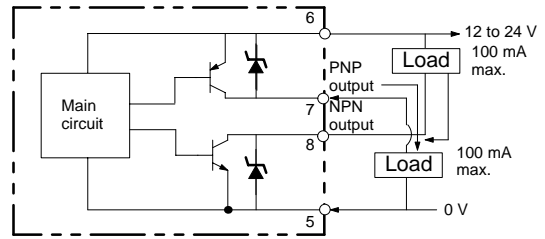

E3C-GE4 NPN Output Type

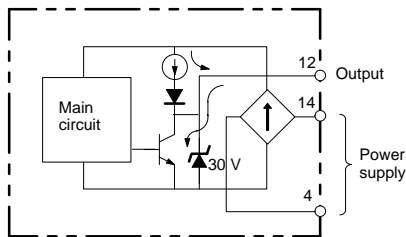

E3C-GF4 PNP Output Type

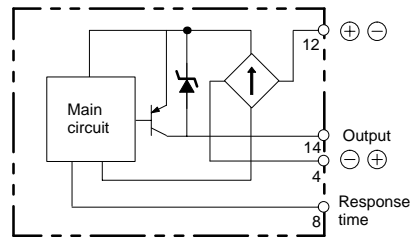

E3C-JC4P NPN Output Type

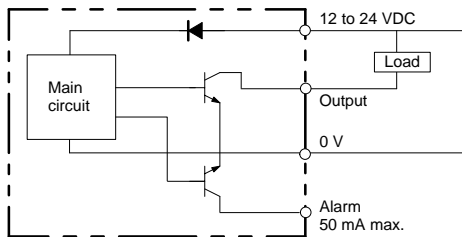

E3C-JB4P PNP Output Type

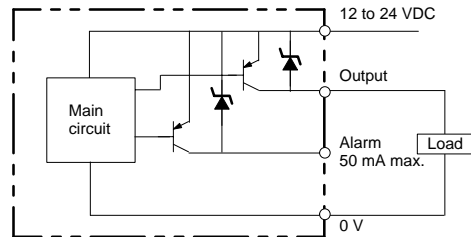

Timing Charts

E3C-A

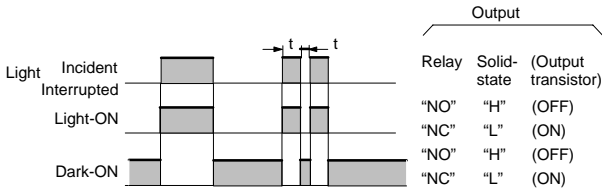

- Note:**
1. Control output is produced only during the input time.
 2. When t exceeds 1 ms or 2 ms, solid-state output is produced. To produce relay output, t must be longer than 20 ms.

E3C-C

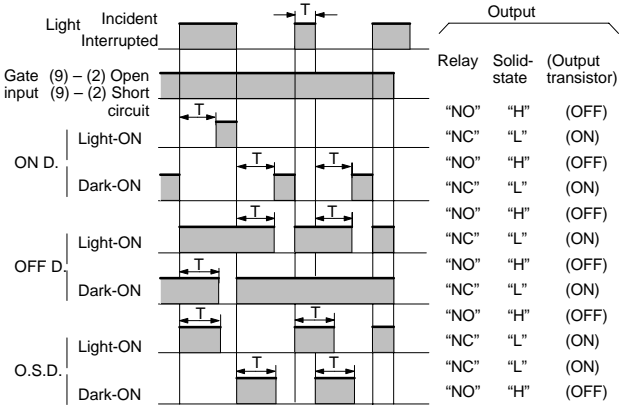

- Note:**
1. t must be longer than 1 ms or 2 ms.
 2. T denotes a delay time.

E3C-WH4F

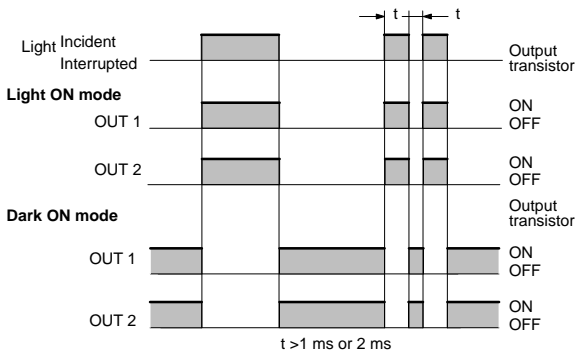

E3C-GE4/E3C-GF4

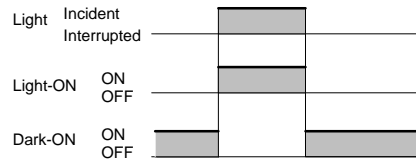

E3C-JC4P/E3C-JB4P

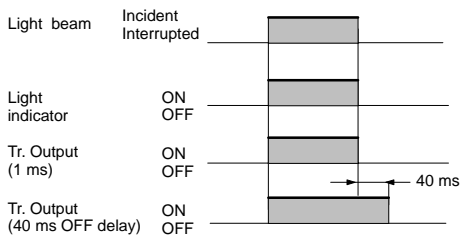

Dimensions

Note: All units are in millimeters unless otherwise indicated.

■ Sensor Units

E3C-S10

Weight: approx. 50 g

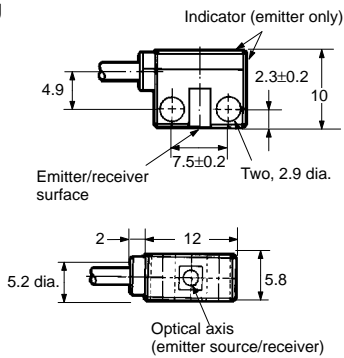
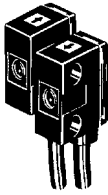

Cord: O.D.: 2.4 dia.
(1C x 12/0.18),
standard length: 2 m

Mounting Bracket (Order Separately) OAC-T1, -T2, -T3

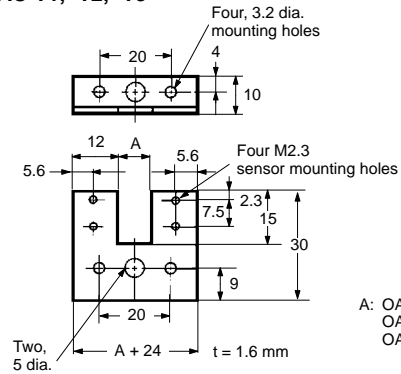

A: OAC-T1:10 mm
OAC-T2:20 mm
OAC-T3:30 mm

E3C-S20W

Weight: approx. 50 g

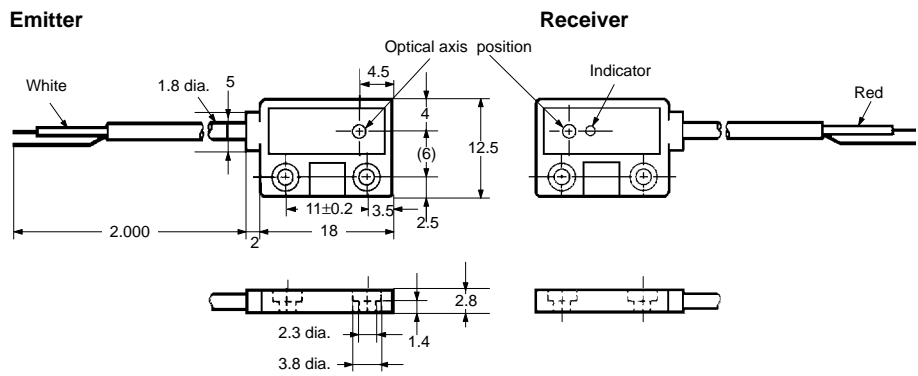
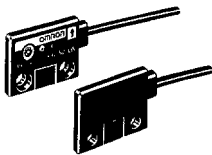

Cord: O.D.: 1.75 dia.
(1C x 12/0.18),
standard length: 2 m

E3C-S30T

Weight: approx. 24 g

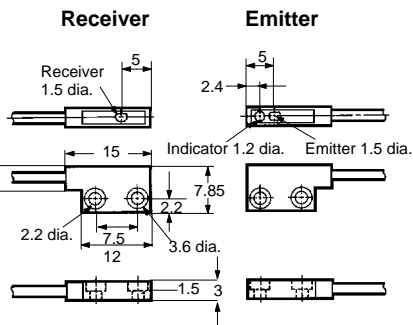
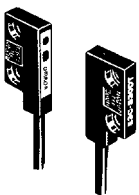

Cord: O.D.: 1.8 dia.
(1C x 30/0.08),
standard length: 2 m

E3C-S30W

Weight: approx. 24 g

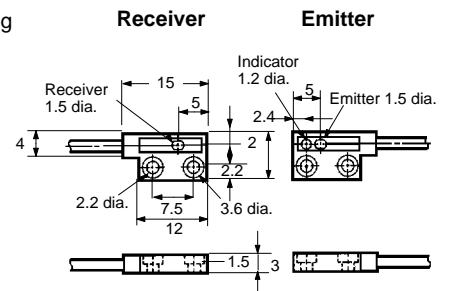
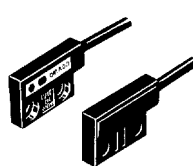

Cord: O.D.: 1.8 dia.
(1C x 30/0.08),
standard length: 2 m

E3C-S50

Weight: approx. 50 g

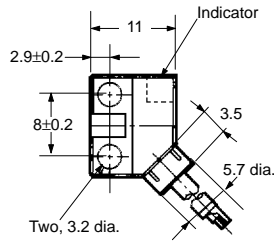
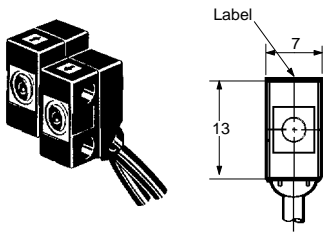

**Mounting Bracket (Order Separately)
E39-L31**

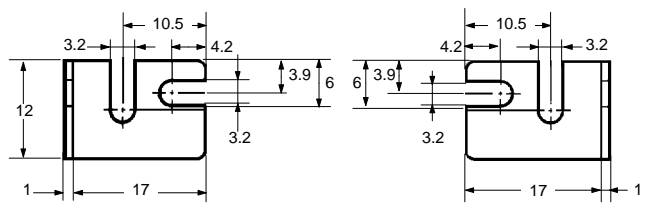

Cord: Polyethelene-insulated round cord, 8.4 dia. (12/0.18 dia.), one-core standard length: 2m

E3C-1

Weight: approx. 60 g

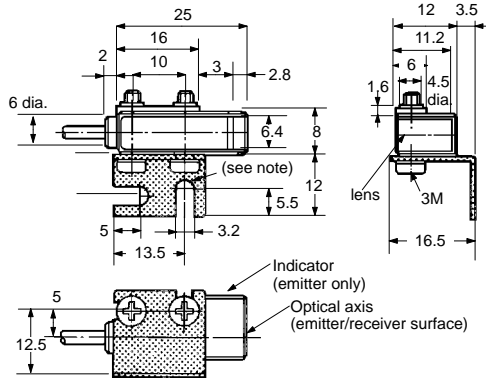
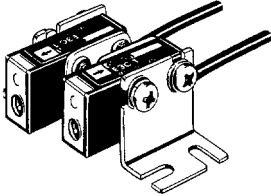

Cord: O.D.: 2.4 dia. (1C x 12/0.18), standard length: 2 m

Note: The mounting bracket is supplied with E3C-1

E3C-2

Weight: approx. 120 g

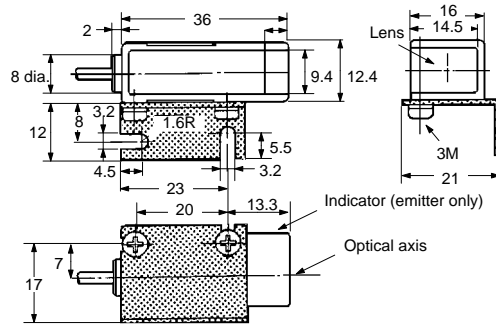
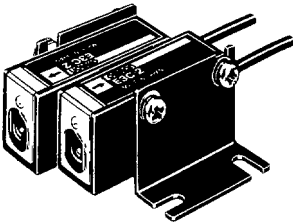

Cord: O.D.: 2.4 dia. (1C x 12/0.18), standard length: 2 m

E3C-DS5W

Weight: approx. 50 g

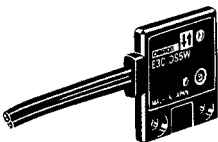

Cord: O.D.: 1.8 x 3.6 (2C x 7/0.18), standard length: 2 m

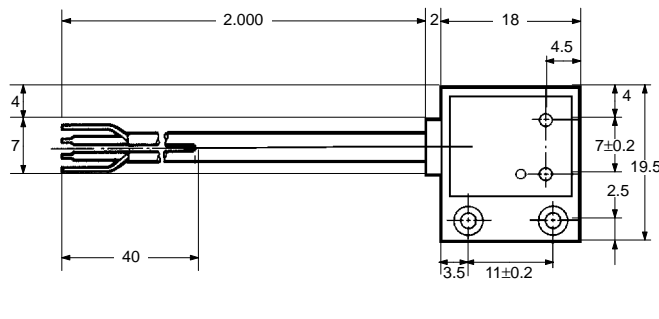

E3C-DS10T

Weight: approx. 50 g

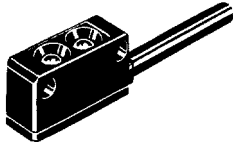

Cord: O.D.: 2.4 x 4.3
(2C x 12/0.18),
standard length: 2 m

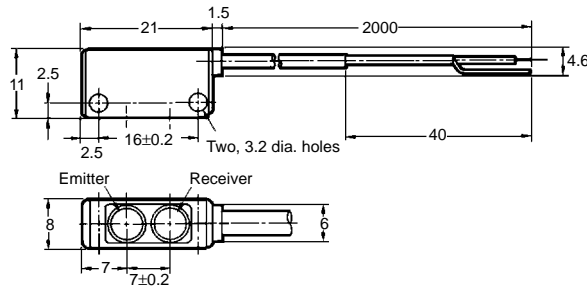

E3C-DS10

Weight: approx. 50 g

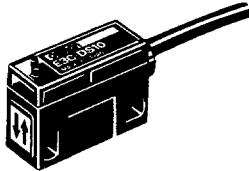

Cord: O.D.: 2.4 x 4.3
(2C x 12/0.18),
standard length: 2 m

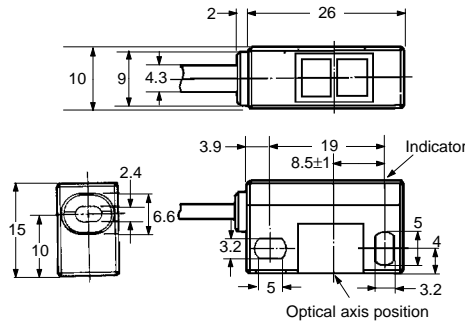

E3C-LS3R

Weight: approx. 55 g

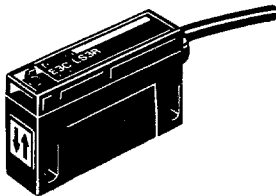

Cord: O.D.: 2.4 x 4.3
(2C x 12/0.18),
standard length: 2 m

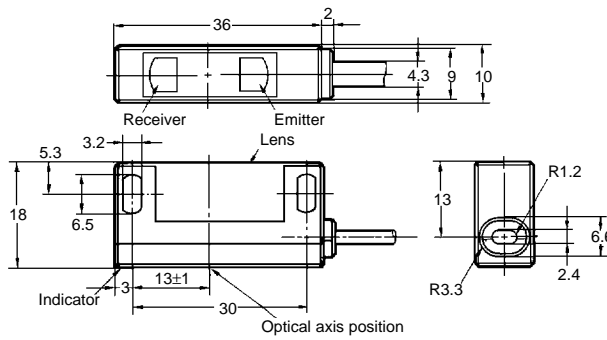

E3C-S5

Weight: approx. 25 g

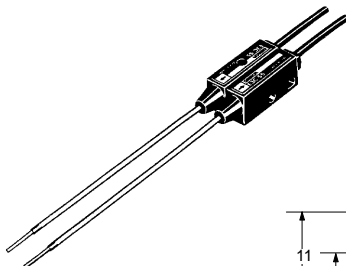

Cord: O.D.: 2.4 dia.
(1C x 12/0.18),
standard length: 2 m

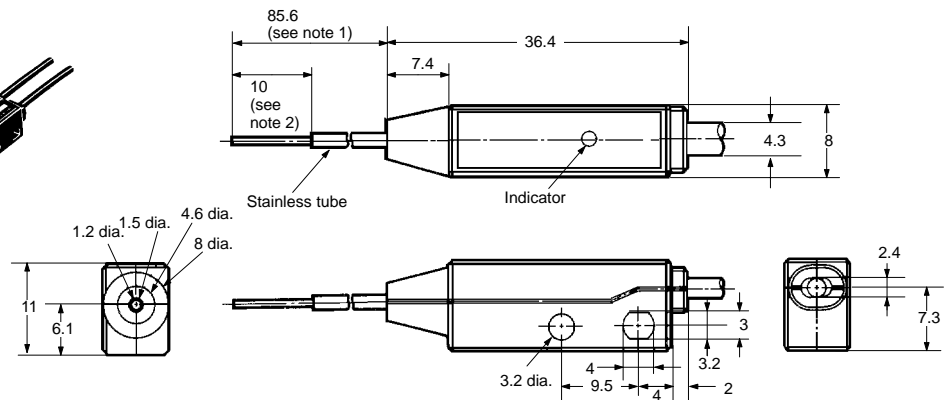

Note: 1. Bendable range (10 mm radius or more)
2. Do not bend this part.

E3C-S5A

Weight: approx. 25 g

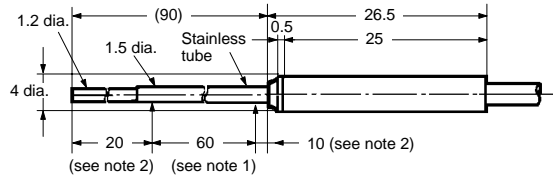
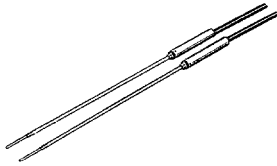

Cord: O.D.: 2.4 dia.
(1C x 12/0.18),
standard length: 2 m

- Note:** 1. Bendable range (10 mm radius or more)
2. Do not bend this part.

Mounting Bracket

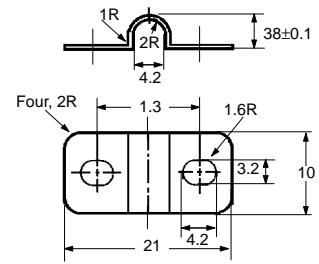

E3C-DM2R

Weight: approx. 50 g

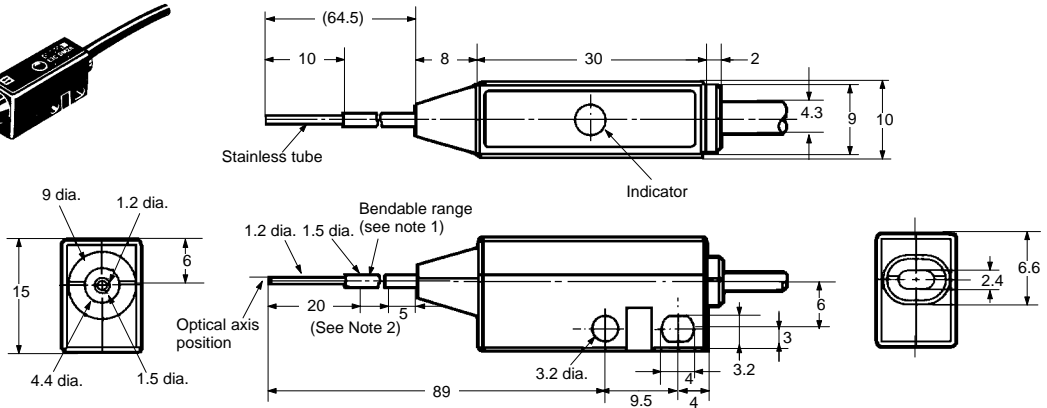
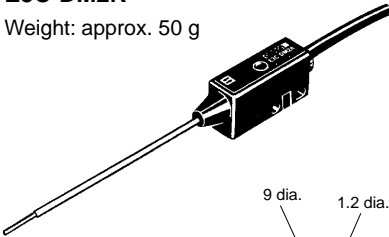

Cord: O.D.: 2.4 x 4.3
(2C x 12/0.18),
standard length: 2 m

- Note:** 1. Bendable range (10 mm radius or more)
2. Do not bend this part.

E3C-DM5-DS1

Weight: approx. 50 g

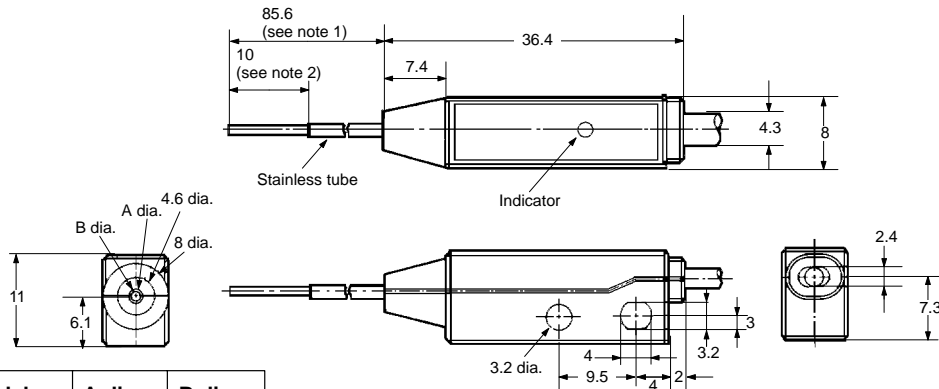
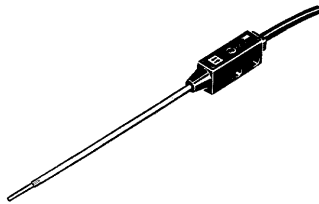

Cord: O.D.: 2.4 x 4.3
(2C x 12/0.18),
standard length: 2 m

Model	A dia.	B dia.
E3C-DS1	2.0 dia.	1.5 dia.
E3C-DM5	1.5 dia.	1.2 dia.

- Note:** 1. Bendable range (10 mm radius or more)
2. Do not bend this part.

E3C-DM5A-DS1A

Weight: approx. 50 g

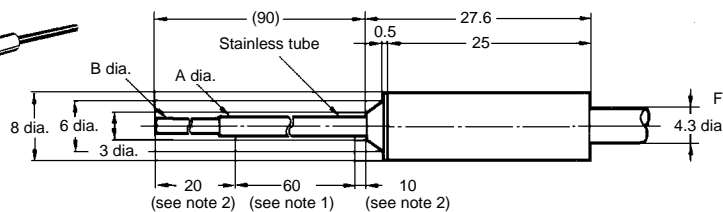
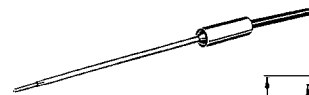

Cord: O.D.: 2.4 x 4.3
(2C x 12/0.18),
standard length: 2 m

Model	A dia.	B dia.
E3C-DS1A	2.0 dia.	1.5 dia.
E3C-DM5A	1.5 dia.	1.2 dia.

Mounting Bracket

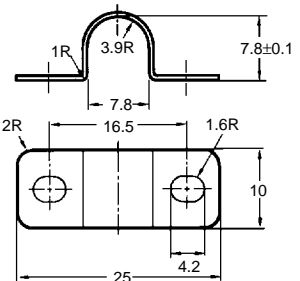

■ Amplifier Units

E3C-A/C

Weight: approx. 220 g
 (The socket PF113A is supplied as an accessory.)

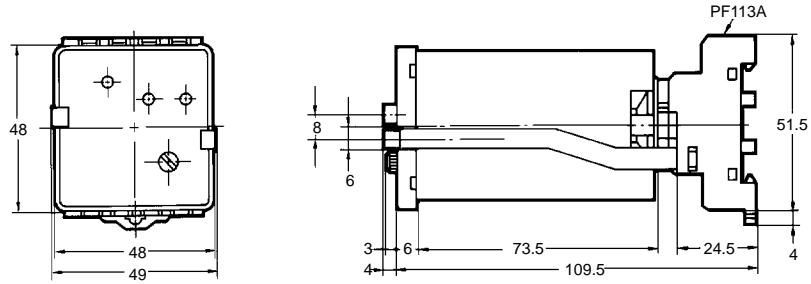
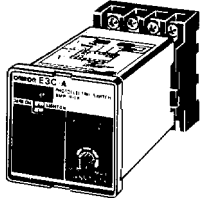

E3C-WH4F

Weight: approx. 100 g

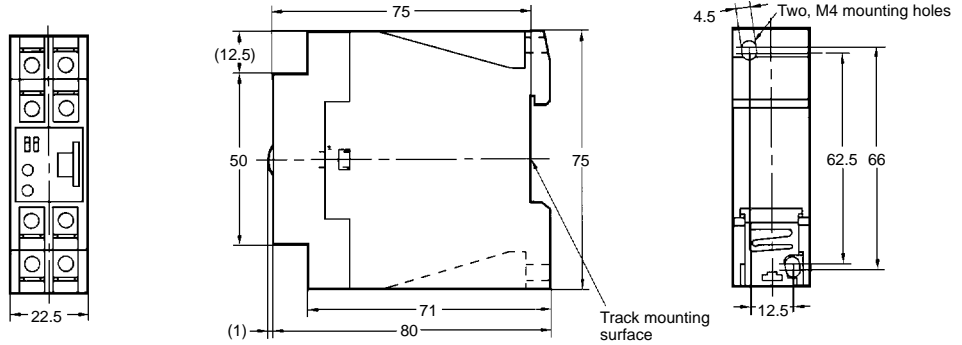
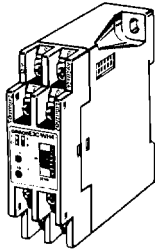

E3C-GE4/GF4

Weight: approx. 15 g

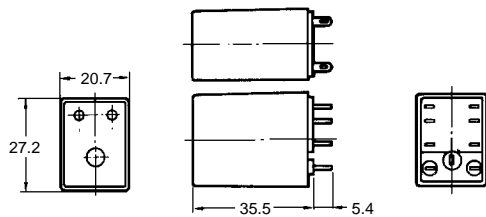

Connecting Socket
 PYF08A Front-connecting Socket
 PY08 Back-connecting Socket

E3C-JC4P/JB4P

Weight: approx. 80 g

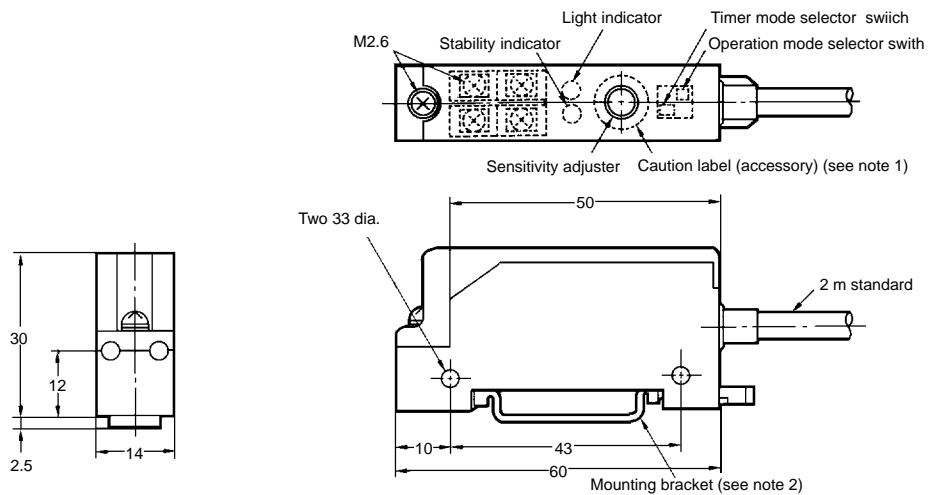
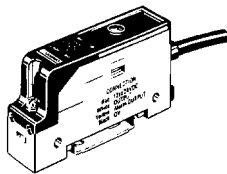

- Note:**
1. Attach the caution label after adjusting the sensitivity adjuster.
 2. This is not necessary when mounting the photoelectric sensor on a track.

■ Accessories

Socket

PF113A (for E3C-A/-C; included)

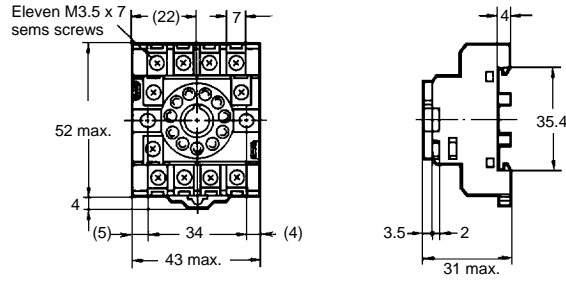
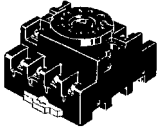

PYF08A (for E3C-GE4/-GF4; Order Separately)

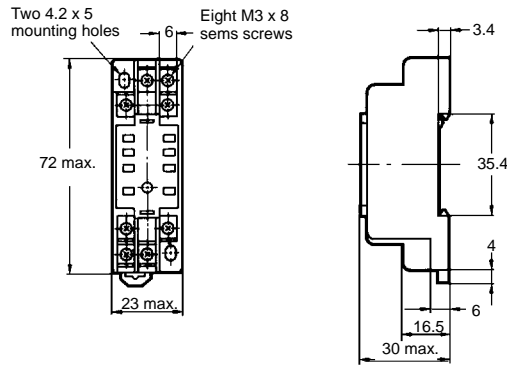
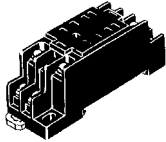

Installation

■ Amplifier Units Connections (to E3C Sensor Units)

E3C-A/E3C-C

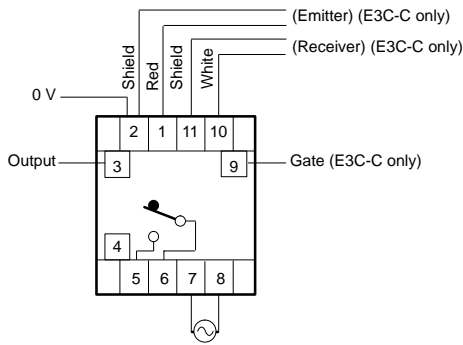

Note: Reflective type in one cord.

E3C-WH4F

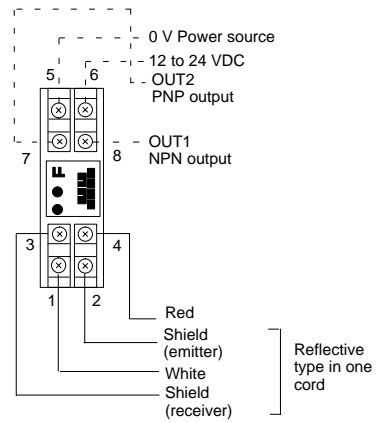

Note: Reflective type in one cord.

E3C-GE4/E3C-GF4

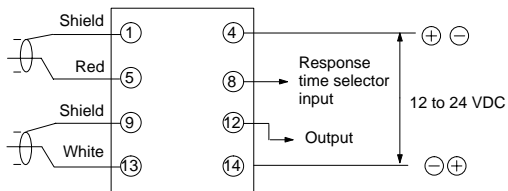

Operation Mode Selection

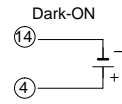
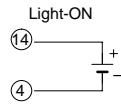

Response Time Selection

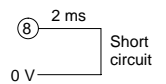
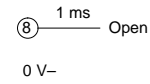

E3C-JC4P/E3C-JB4P

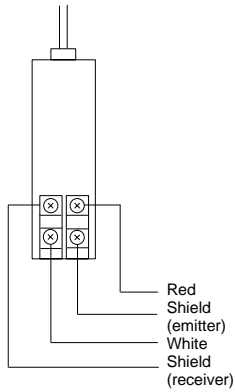

ALL DIMENSIONS SHOWN ARE IN MILLIMETERS.

To convert millimeters into inches, multiply by 0.03937. To convert grams into ounces, multiply by 0.03527.

Cat. No. E31-E1-7B **In the interest of product improvement, specifications are subject to change without notice.**

OMRON Corporation

Systems Components Division H.Q.

28th Fl., Crystal Tower Bldg.

1-2-27, Shiromi, Chuo-ku,

Osaka 540 Japan

Phone: 06-949-6012 Fax: 06-949-6021

Printed in Japan

0597-0.5M (0494) Ⓐ