

**15, 30, 50 Watt AC-DC (DC-DC) Converters Convert Simply**



**Features**

**Universal input range 100 - 240 VAC**  
**Additional DC input 90 - 250 V**  
**Single output 5.1, 12, 24, or 48 VDC**  
**Class I equipment**

- Extremely compact design
- Battery charger versions
- Operating ambient temperature range -10 to 50°C with convection cooling

Safety according to IEC/EN 60950, UL 1950, and UL 508 <sup>2</sup>



<sup>1</sup> LOK

<sup>2</sup> LOS/LOR only

**Description**

The Convert Simply front-end converters represent a family of 15, 30, and 50 watt DIN-rail mountable AC-DC converters for use as rectifiers or battery chargers. Plastic casing, compact size, and high reliability make the LOS, LOR, LOK4000 Series an excellent choice for space-critical applications, where a DIN-Rail mountable AC-DC converter is required. The universal input range and a built-in input filter allow flexible operation in a wide variety of electronic equipment and enables worldwide connection to the mains.

The converters are available as rectifiers with 12 V, 24 V, or 48 V single output and as battery chargers for 12 V, 24 V, or 48 V batteries. The output voltage of LOK converters can be adjusted via the R input.

Safety approvals fully comply with worldwide requirements.

**Applications**

Typical applications are: powering building controls, factory automation, industrial controls, instrumentation, electromagnetic drives, fans, and other DC loads.

**Table of Contents**

|                              | Page |  | Page |
|------------------------------|------|--|------|
| Description .....            | 1    | Electromagnetic Compatibility (EMC) .....  | 7    |
| Features .....               | 1    | Mechanical Data .....                      | 8    |
| Model Selection .....        | 2    | Immunity to Environmental Conditions ..... | 8    |
| Functional Description ..... | 3    | Safety and Installation Instructions ..... | 9    |
| Electrical Input Data .....  | 3    | Description of Options .....               | 11   |
| Electrical Output Data ..... | 4    | EC Declaration of Conformity LOS/LOR ..... | 12   |
| Auxiliary Functions .....    | 6    | EC Declaration of Conformity LOK .....     | 13   |

### Model Selection

Table 1: Type survey

| Output                      |                  | Operating input voltage <sup>1</sup>       | Rated power                                    | Efficiency <sup>5</sup> | Model        | Options <sup>4</sup> |
|-----------------------------|------------------|--|--|-------------------------|--------------|----------------------|
| $V_{o\ nom}$ [VDC]          | $I_{o\ nom}$ [A] |  | $T_A = 50\ ^\circ\text{C}$<br>$P_{o\ tot}$ [W] | $\eta_{typ}$ [%]        |              |                      |
| 5.1                         | 5.2              | 85 - 264 VAC<br>47 - 63 Hz<br>90 - 250 VDC | 26   | 70                      | LOK4001-2RLD | F <sup>2</sup> , K   |
| 12                          | 1.25             |  | 15   | 74                      | LOS4301-2    |                      |
| 12                          | 2.5              |  | 30   | 80                      | LOR4301-2    |                      |
| 12                          | 4                |  | 48   | 82                      | LOK4301-2R   |                      |
| 12 - 12.8 <sup>3</sup> - 15 | 3.6              |  | 49   | 82                      | LOK4140-2RLD |                      |
| 24                          | 0.65             |  | 15   | 76                      | LOS4601-2    |                      |
| 24                          | 1.25             |  | 30   | 82                      | LOR4601-2    |                      |
| 24                          | 2                |  | 48   | 82                      | LOK4601-2R   |                      |
| 24 - 25.7 <sup>3</sup> - 30 | 1.8              |  | 49   | 82                      | LOK4240-2RLD |                      |
| 48                          | 1                |  | 48   | 82                      | LOK4801-2R   |                      |
| 48 - 51.4 <sup>3</sup> - 60 | 0.9              | 49   | 81   | LOK4740-2RLD            |              |                      |

<sup>1</sup> Linear derating to 85% of  $P_{o\ nom}$  below  $V_i = 105$  VAC, 110 VDC

<sup>2</sup> LOK types only

<sup>3</sup> Setting voltage  $V_{o\ set}$  for battery chargers with R-input left open-circuit.

<sup>4</sup> For minimum order quantities and lead times contact Power-One.

<sup>5</sup> Efficiency at  $V_{i\ rated}$  and  $I_{o\ nom}$

### Part Number Description and Product Marking

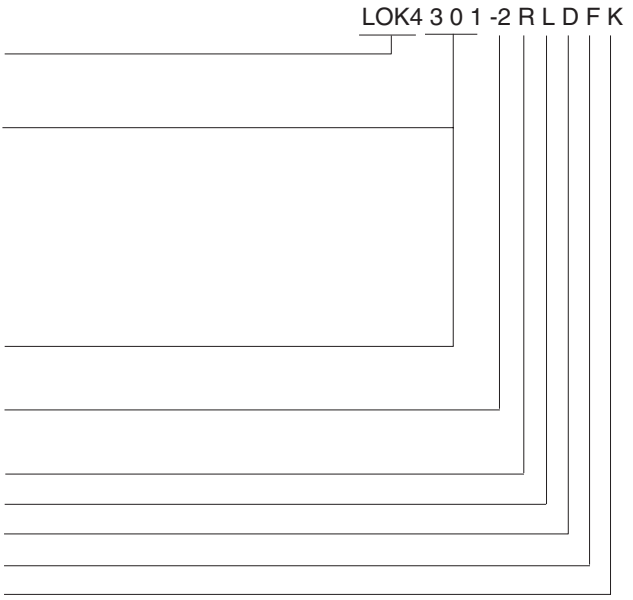
|                                   |   |  |  |
|-----------------------------------|---|--|--|
| Series                            | 15 W ..... LOS 4<br>30 W ..... LOR 4<br>50 W ..... LOK 4  |  | <b>LOK4 3 0 1 -2 R L D F K</b><br> |
| Output                            | 5.1 V rectifier version ..... 001<br>12 V rectifier version ..... 301<br>24 V rectifier version ..... 601<br>48 V rectifier version ..... 801<br>12 - 15 V battery charger ..... 140<br>24 - 30 V battery charger ..... 240<br>48 - 60 V battery charger ..... 740<br>other voltages or specs. .... 02 - 99 |  |  |
| Ambient temperature range $T_A$ : | -10 to 50°C ..... -2 <sup>3</sup>   |  |  |
| Features and options:             | Output voltage control input ..... R <sup>2</sup><br>Rectangular output characteristic ..... L <sup>1</sup><br>Output voltage OK signal ..... D <sup>1</sup><br>Built-in second fuse (option) ..... F <sup>2</sup><br>K system connector (option) ..... K   |  |  |

<sup>1</sup> Battery chargers and LOK4001-2RLD

<sup>2</sup> LOK models only

<sup>3</sup> Up to 70 °C with derating

Examples: LOK4140-2RLD: AC-DC converter, battery charger version, providing 12 - 15 V/3.6 A at the output  
 LOK4601-2R: AC-DC converter, rectifier version, providing 24 V/2 A, 48 W at the output

**Functional Description**

The Convert Simply 15, 30, and 50 watt front-end modules are flyback converters with a fixed frequency of 100 kHz (LOK) or 130 kHz (LOR, LOS). The battery charger modules and the

LOK4001-2RLD have a rectangular  $V/I$  output characteristic. The rectifier modules have overload protection working in a hiccup mode.

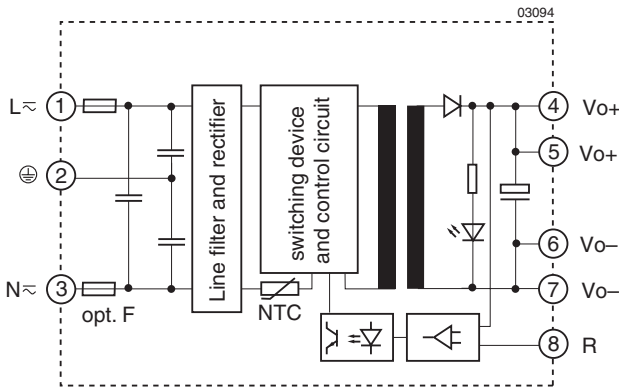

Fig. 1  
Block diagram LOK4301, LOK4601 and 4801 (rectifier versions), all LOR and all LOS.

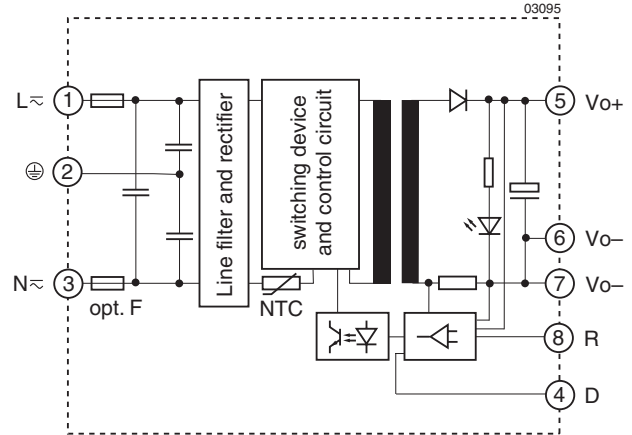

Fig. 2  
Block diagram LOK4140, LOK4240 and LOK4740 (battery charger versions) and LOK4001-2RLD.

**Electrical Input Data**

General Condition:  $T_A = 25\text{ }^\circ\text{C}$  unless otherwise specified

Table 2: Input data

| Characteristics       |  | LOS                  | LOR                  | LOK                  | Unit |
|-----------------------|--|----------------------|----------------------|----------------------|------|
| $V_{i\text{ rated}}$  | Rated input voltages                                     | 100 - 240            | 100 - 240            | 100 - 240            | VAC  |
| $V_{i\text{ nom}}$    | Nominal input voltage                                    | 230                  | 230                  | 230                  |      |
| $V_i$                 | Operating input voltage range                            | 85 - 264<br>90 - 250 | 85 - 264<br>90 - 250 | 85 - 264<br>90 - 250 |      |
| $f_i$                 | Nominal line frequency                                   | 50 - 60              | 50 - 60              | 50 - 60              | Hz   |
| $I_i$                 | Input current at 115/230 VAC <sup>1</sup>                | 0.3/0.15             | 0.52/0.26            | 0.8/0.4              | A    |
| $I_{i\text{ nl}}$     | Input current at 230 VAC and no load                     |                      |                      | 0.035                |      |
| $I_{i\text{ nr max}}$ | Peak inrush current at $V_i = 230\text{ V}$ <sup>2</sup> | 18                   | 18                   | 19                   |      |

<sup>1</sup> At  $I_{o\text{ nom}}$ . <sup>2</sup> Inrush current limitation by a 16  $\Omega$  NTC resistor.

**Electrical Output Data**

General Conditions: –  $T_A = 25\text{ }^\circ\text{C}$  unless otherwise specified. R input not connected.

Table 3a: Output data

| Output             |                                       |   | LOK4001-2RLD | LOS/LOR/LOK<br>4301-2(R) | LOS/LOR/LOK<br>4601-2(R) | LOK4801-2R  | Unit             |
|--------------------|---------------------------------------|---|--------------|--------------------------|--------------------------|-------------|------------------|
| Characteristics    | Conditions                            |   | min typ max  | min typ max              | min typ max              | min typ max |                  |
| $V_o$              | Output voltage $V_{o\text{ nom}}$     | $V_{i\text{ nom}}, 0.5 I_{o\text{ nom}}$                                      | 5.1          | 12                       | 24                       | 48          | V                |
|                    | $V_o$ setting tolerance               | R-input open-circuit  | $\pm 1.5$    | $\pm 1.5$                | $\pm 1.5$                | $\pm 1.5$   | %                |
| $V_{o\text{ adj}}$ | Adjustable voltage range              | Units with feature R  | 4.5 - 5.5    | 10.8 - 13.2              | 21.6 - 26.4              | 43.2 - 52.8 | V                |
| $I_{o\text{ nom}}$ | Nominal output current                | $V_{i\text{ min}} - V_{i\text{ max}}$   | 5.2          | 1.25 2.5 4.0             | 0.65 1.25 2.0            | 1           | A                |
| $v_o$              | Output voltage noise<br>(BW = 20 MHz) | $V_{i\text{ nom}}, I_{o\text{ nom}}$ ,<br>IEC 61200                           | 50           | 100 150                  | 100 150                  | 200         | mV <sub>pp</sub> |
|                    | Static line/load regulation           | $V_{i\text{ min}} - V_{i\text{ max}}$ ,<br>$I_o = (0.1 - 1) I_{o\text{ nom}}$ | $\pm 1$      | $\pm 1$                  | $\pm 1$                  | $\pm 1$     | %                |
| $V_{o\text{ l}}$   | Dynamic load regulation               | $V_{i\text{ nom}}, (0.1 \times 0.9) I_{o\text{ nom}}$                         | $\pm 5$      | $\pm 2$                  | $\pm 1.5$                | $\pm 1$     | %                |
| $t_r$              | Transient recovery time               | $I_o = (0.1 \times 0.9) I_{o\text{ nom}}$                                     | 4            | 4                        | 4                        | 4           | ms               |
| $t_h$              | Hold-up time                          | 115 / 230 VAC   | 14 / 60      | 14 / 90                  | 14 / 90                  | 14/90       | ms               |
| $\alpha_{U_o}$     | Temper. coefficient of $V_o$          | $V_{i\text{ nom}}, I_{o\text{ nom}}$  | $\pm 0.05$   | $\pm 0.05$               | $\pm 0.05$               | $\pm 0.05$  | %/K              |
| $f_s$              | Switching frequency                   |   | 100          | 100 <sup>1</sup>         | 100 <sup>1</sup>         | 100         | kHz              |

<sup>1</sup> LOR and LOS have 130 kHz.

Table 3b: Output data

| Output             |                                       |   | LOK4140-2RLD            | LOK4240-2RLD            | LOK4740-2RLD            | Unit             |
|--------------------|---------------------------------------|---|-------------------------|-------------------------|-------------------------|------------------|
| Characteristics    | Conditions                            |   | min typ max             | min typ max             | min typ max             |                  |
| $V_o$              | Output voltage                        | $V_{i\text{ nom}}, 0.5 I_{o\text{ nom}}$<br>R-input open-circuit              | 12.84 <sup>1</sup>      | 25.68 <sup>1</sup>      | 51.36 <sup>1</sup>      | V                |
| $V_{o\text{ adj}}$ | Adjustable voltage range              |   | 12.0 - 15.0             | 24.0 - 30.0             | 48.0 - 60.0             |                  |
| $I_{o\text{ nom}}$ | Nominal output current                | $V_{i\text{ min}} - V_{i\text{ max}}$   | 3.6                     | 1.8                     | 0.9                     | A                |
| $v_o$              | Output voltage noise<br>(BW = 20 MHz) | $V_{i\text{ nom}}, I_{o\text{ nom}}$<br>IEC 61204                             | 100 150                 | 100 150                 | 200                     | mV <sub>pp</sub> |
|                    | Static line/load regulation           | $V_{i\text{ min}} - V_{i\text{ max}}$ ,<br>$I_o = (0.1 - 1) I_{o\text{ nom}}$ | $\pm 2$ <sup>1</sup>    | $\pm 1$ <sup>1</sup>    | $\pm 1$ <sup>1</sup>    | %                |
| $V_{o\text{ l}}$   | Dynamic load regulation               | $V_{i\text{ nom}}, (0.1 \times 0.9) I_{o\text{ nom}}$                         | $\pm 2$ <sup>1</sup>    | $\pm 1.5$ <sup>1</sup>  | $\pm 1$ <sup>1</sup>    | %                |
| $t_r$              | Transient recovery time               | $I_o = (0.1 \times 0.9) I_{o\text{ nom}}$                                     | 4                       | 4                       | 4                       | ms               |
| $t_h$              | Hold-up time                          | 115/230 VAC   | 14 / 90                 | 14 / 90                 | 14 / 90                 | ms               |
| $\alpha_{U_o}$     | Temper. coefficient of $V_o$          | $V_{i\text{ nom}}, I_{o\text{ nom}}$  | $\pm 0.05$ <sup>1</sup> | $\pm 0.05$ <sup>1</sup> | $\pm 0.05$ <sup>1</sup> | %/K              |
| $f_s$              | Switching frequency                   |   | 100                     | 100                     | 100                     | kHz              |

<sup>1</sup> R input left open-circuit.

**Thermal Considerations**

If an AC-DC converter is located in free, quasi-stationary air (convection cooling) at the indicated maximum ambient temperature  $T_{A\max}$  (see table: *Temperature specifications*) and is operated at its nominal input voltage and output power, the temperature measured at the *Measuring point of case temperature*  $T_C$  (see *Mechanical Data, valid for LOK types*) will approach the indicated value  $T_{C\max}$  after the warm-up phase. However, the relationship between  $T_A$  and  $T_C$  depends heavily on the conditions of operation and integration into a system. The thermal conditions are influenced by input voltage, output current, airflow, temperature of surrounding components and surfaces.  $T_{A\max}$  is therefore, contrary to  $T_{C\max}$ , an indicative value only.

The relation between the maximum allowed output power  $P_{o\text{ allowed}}$  and the temperature  $T_A$  of the surrounding air is given in Fig. *Maximum allowed output power vs. ambient temperature*. The rates apply if the AC-DC converter is located in free, quasi-stationary air (convection cooling).

**Note:** Sufficient forced cooling allows  $T_A$  to be higher than the value given in the table if  $T_{C\max}$  according to the table is not exceeded.

**Caution:** The installer must ensure that under all operating conditions  $T_C$  remains within the limits that are stated in the table *Temperature specifications*.

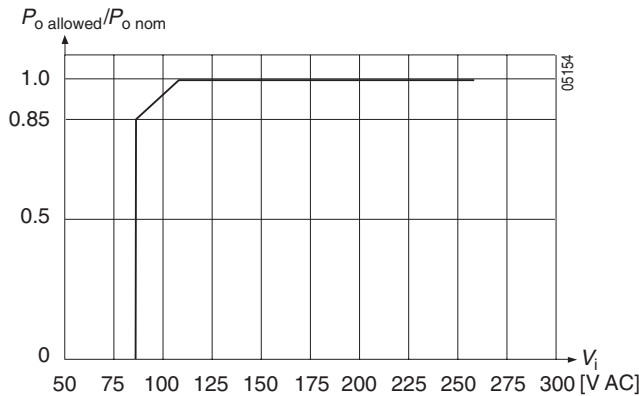

**Fig. 3**  
*Maximum allowed output power versus input voltage at  $T_A$  50°C. for LOK models.*

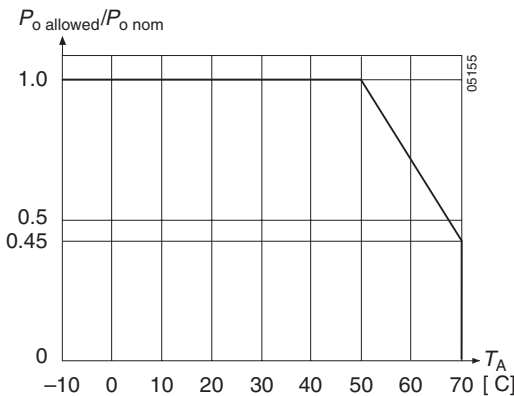

**Fig. 4**  
*Maximum allowed output power versus ambient temperature at  $V_i > 105$  VAC for LOK models.*

**Output Overload Protection**

Battery charger versions LOK4140-, 4240-, LOK4740-2RLD, and the LOK4001-2RLD have a rectangular current limitation characteristic, which limits the output current to within  $(1 - 1.3) \cdot I_{o\text{ nom}}$ . The other types are protected against overload by a current limiting device, which shuts down the converter in overload condition. It automatically restarts after removal of the overload condition (hiccup mode).

**Outputs Connected in Series**

Two or more converters supplying the same or different output voltages may be connected in series. The value of the maximum output current to be taken is defined by that unit providing the lowest current limiting value. It should be assured that the outputs do not feed backwards into each other caused by their different rise/fall times at switch-on/off cycles by adding reverse polarity diodes across each output.

**Parallel Operation**

Only possible with battery charger versions. The outputs of several battery charger models with equal output voltage (e.g. several LOK 4240-2RLD) can be connected in parallel.

**Auxiliary Functions**

**Adjustable Output Voltage (R input)**

As a standard feature, the LOK units offer adjustable output voltage by using the control input R. If the R pin is left open-circuit, the output voltage is set to  $V_{o\ nom}$ . (see: *Output data*)

The R input is referenced to the secondary side of the converter. Adjustment of the output voltage is possible by means of either an external resistor or a voltage source.

a) Adjustment by means of an external resistor  $R_{ext1}$ :

Depending upon the value of the required output voltage, the resistor shall be connected

**either:** Between the R terminal and  $V_{o-}$  to achieve an output voltage adjustment range of approximately  $V_o = 90 - 100\% V_{o\ nom}$ . (LOK4301, 4601 and 4801 types)

$$R_{ext1} \approx 4\ k\Omega \cdot \frac{V_o}{V_{o\ nom} - V_o}$$

**or:** Between the R terminal and  $V_{o+}$  to achieve an output voltage range of approximately  $V_o = 100 - 110\% V_{o\ nom}$  for rectifier versions and  $100 - 125\% V_{o\ nom}$  for battery chargers.

$$R_{ext2} \approx 4\ k\Omega \cdot \frac{(V_o - 2.5\ V)}{2.5\ V \cdot (V_o/V_{o\ nom} - 1)}$$

b) Adjustment by means of an external voltage  $V_{ext}$  between  $V_{o-}$  and R terminal to achieve an output voltage adjustment range of approx.  $90 - 110\% V_{o\ nom}$  (LOK 4301, 4601 and 4801 types),  $93 - 117\% V_{o\ nom}$  for battery chargers.

$$V_{ext} \approx \frac{V_o \cdot 2.5\ V}{V_{o\ nom}}$$

Attempting to adjust the output below this range will cause the converter to shut down (hiccup mode).

**Note:** Applying an external control voltage  $>3\ V$  may damage the converter.

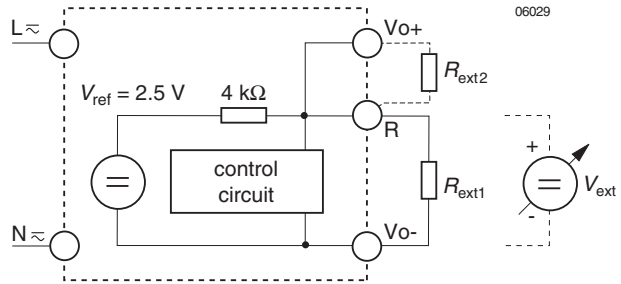

**Output Voltage OK (D output)**

The D-output is referenced to  $V_{o-}$  and monitors the output voltage  $V_o$ . If  $V_o$  drops below  $V_{o\ t}$ , the D-output will be disabled (open-collector circuit). The circuitry works independently of the input voltage and can therefore be used as battery-low indicator.

Table 4: Output Voltage OK signal

| Conditions |   | LOK4001-2RLD |     | LOK4140-2RLD |      | LOK4240-2RLD |     | LOK4740-2RLD |     | Unit |
|------------|---|--------------|-----|--------------|------|--------------|-----|--------------|-----|------|
|            |   | min          | max | min          | max  | min          | max | min          | max |      |
| $V_{o\ t}$ | setting                                 | 4.4          | 4.8 | 10.5         | 11.5 | 21           | 23  | 42           | 46  | V    |
| $V_D$      | $V_o - V_{o\ t\ min}$                   |              | 60  |              | 60   |              | 60  |              | 60  |      |
|            | $V_o > V_{o\ t\ max}$<br>$I_D < 50\ mA$ |              | 0.6 |              | 0.6  |              | 0.6 |              | 0.6 |      |

**Battery Charging/Temperature Sensor**

The LOK 4140/4240/4740 are designed to charge lead-acid batteries. For optimum battery charging and extended life time of the battery an external temperature sensor may be connected to the R-input. The sensor should be mounted as close as possible to one of the poles of the battery.

Depending upon the cell voltage and the temperature coefficient of the battery, different temperature sensors are available. For more information please see: *Temperature Sensors* (Accessory Products on the Web Site) or contact Power-One.

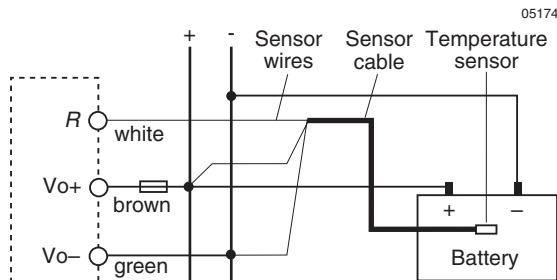

Fig. 6  
Voltage setting by a temperature sensor, wiring diagram

If no sensor is used, the float charge voltage should be adjusted with a suitable resistor connected to the R input (see: *Adjustable Output voltage*).

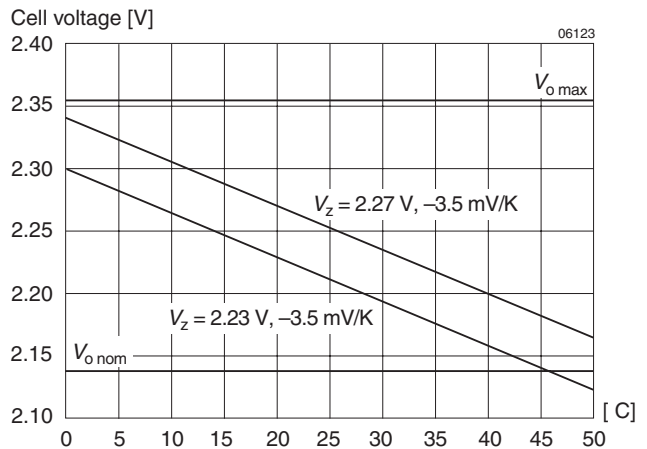

Fig. 7  
Float charge voltage vs. temperature for defined temperature coefficient.

**Electromagnetic Compatibility (EMC)**

**Immunity**

A metal-oxide VDR together with the input fuse and the input filter form an effective protection against high input transient voltages, which typically occur in most installations. The LOS, LOR, and LOK4000 Series have been successfully tested to the following specifications:

Table 5: Immunity type tests

| Phenomenon                       | Standard <sup>1</sup> | Level | Coupling mode <sup>2</sup> | Value applied       | Waveform  | Source imped. | Test procedure  | Per-form. <sup>3</sup> |
|----------------------------------|-----------------------|-------|----------------------------|---------------------|---|---------------|---|------------------------|
| Electrostatic discharge          | IEC/EN 61000-4-2      | 2     | air discharge              | 8000 V <sub>p</sub> | 1/50 ns   | 330 Ω         | 10 positive and 10 negative discharges                            | B                      |
| Electromagnetic field            | IEC/EN 61000-4-3      | 2     | antenna                    | 3 V/m               | AM 80%<br>1 kHz   | n.a.          | 80...1000 MHz<br>900 MHz<br>1800 MHz                              | B                      |
| Electrical fast transients/burst | IEC/EN 61000-4-4      | 3     | direct, i/⊕, +i/-i         | 2 kV <sub>p</sub>   | bursts of 5/50 ns<br>2.5/5 kHz over<br>15 ms; burst<br>period: 300 ms | 50 Ω          | 60 s positive<br>60 s negative<br>transients per<br>coupling mode | B                      |
| Surge                            | IEC/EN 61000-4-5      | 3     | i/⊕                        | 2 kV <sub>p</sub>   | 1.2 / 50 μs   | 12 Ω          | 5 pos. and 5 neg.<br>surges per                                   | A                      |
|                                  |                       | 2     | +i/-i                      | 1 kV <sub>p</sub>   |   | 2 Ω           |   |                        |
| Conducted disturbances           | IEC / EN 61000-4-6    | 2     | box                        | 3 VAC               | AM 80%<br>1 kHz   | 150 Ω         | 0.15 - 80 MHz   | A                      |

<sup>1</sup> Related and previous standards are referenced in: *Technical Information: Standards*

<sup>2</sup> i = input, o = output, ⊕ = PE case.

<sup>3</sup> A = Normal operation, no deviation from specifications, B = Normal operation, temporary deviation from specs possible.

**Emission**

Internal input filtering keeps the conducted noise of the converters within the frequency range of 10 kHz to 30 MHz below level B according to EN 55011 and EN 55022 standards.

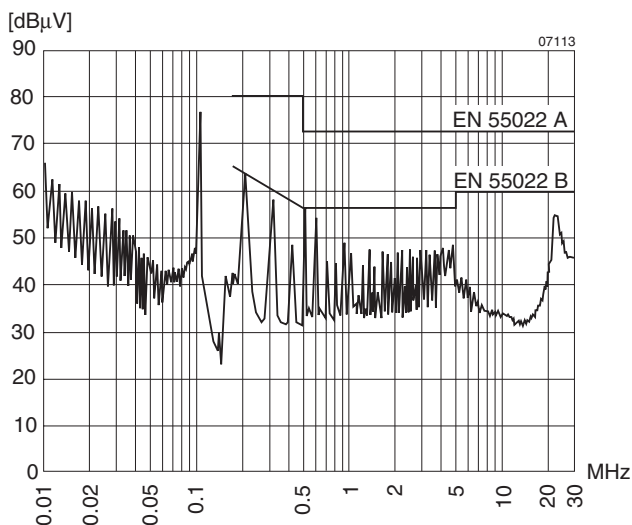

Fig. 8  
Typical disturbance voltage (quasi-peak) at the input according to EN 55011/22, measured at  $V_{i\text{ nom}}$  and  $I_{o\text{ nom}}$ . LOK4601-2R,  $V_i = 230\text{ VAC}$ .

**Immunity to Environmental Conditions**

Table 6: Mechanical stress

| Test Method |                         | Standard  | Test Conditions   | Status             |
|-------------|-------------------------|---|---|--------------------|
| Ca          | Damp heat steady state  | IEC/EN 60068-2-78<br>MIL-STD-810D section 507.2 | Temperature: 40 ±2 °C<br>Relative humidity: 93 +2/-3 %<br>Duration: 21 days   | Unit not operating |
| Ea          | Shock (half-sinusoidal) | IEC/EN 60068-2-27<br>MIL-STD-810D section 516.3 | Acceleration amplitude: 15 g <sub>n</sub> = 147 m/s <sup>2</sup><br>Bump duration: 11 ms<br>Number of bumps: 18 (3 each direction)                              | Unit operating     |
| Eb          | Bump (half-sinusoidal)  | IEC/EN 60068-2-29<br>MIL-STD-810D section 516.3 | Acceleration amplitude: 10 g <sub>n</sub> = 98 m/s <sup>2</sup><br>Bump duration: 11 ms<br>Number of bumps: 6000 (1000 each direction)                          | Unit operating     |
| Fc          | Vibration (sinusoidal)  | IEC/EN 60068-2-6<br>MIL-STD-810D section 514.3  | Acceleration amplitude: 0.15 mm (10 - 60 Hz)<br>2 g <sub>n</sub> = 20 m/s <sup>2</sup> (60 - 150 Hz)<br>10 - 150 Hz<br>Test duration: 3.75 h (1.25 h each axis) | Unit operating     |

Table 7: Temperature specifications

| Characterisitcs |                     | Conditions               | min | max | Unit |
|-----------------|---------------------|--------------------------|-----|-----|------|
| T <sub>A</sub>  | Ambient temperature | Operational <sup>1</sup> | -10 | 50  | °C   |
| T <sub>C</sub>  | Case temperature    |                          | -10 | 80  |      |
| T <sub>S</sub>  | Storage temperature | Non operational          | -40 | 85  |      |

<sup>1</sup> See: Thermal Consideration.

Table 8: MTBF Values

| MTBF                                 | Type | Ground benign          |                        | Ground fixed           |                        | Ground mobile | Unit |
|--------------------------------------|------|------------------------|------------------------|------------------------|------------------------|---------------|------|
|                                      |      | T <sub>C</sub> = 40 °C | T <sub>C</sub> = 40 °C | T <sub>C</sub> = 70 °C | T <sub>C</sub> = 50 °C |               |      |
| According to MIL-HDBK-217F, Notice 2 | LOK  | 1 600 000              | 400 000                | 200 000                | 120 000                | h             |      |

**Mechanical Data**

Dimensions in mm. Tolerance ±0.3 mm unless otherwise indicated.

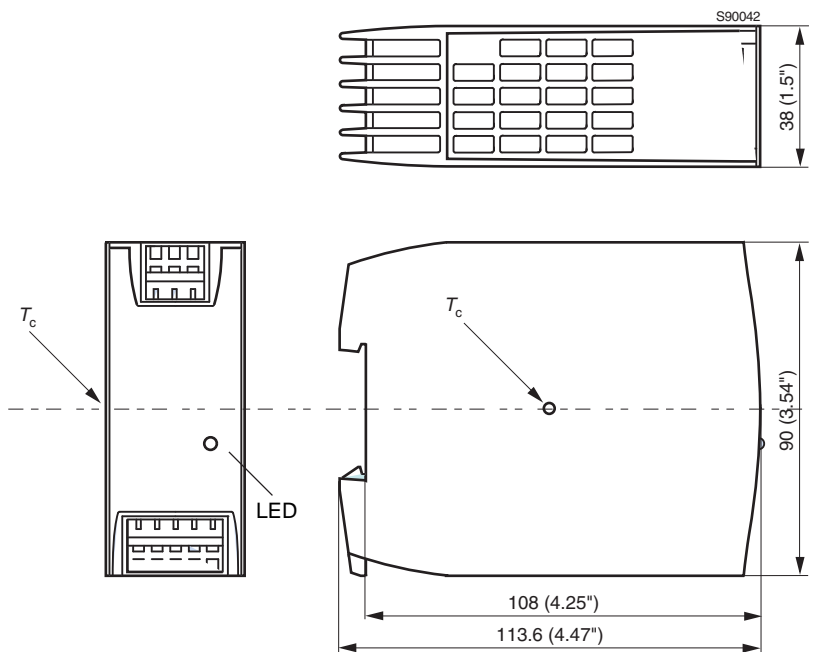

Fig. 9  
Case



### Safety and Installation Instructions

#### Terminal Allocation

The terminal allocation table defines the electrical potentials of the AC-DC converters. For mechanical positions of the terminals see: *Mechanical Data*.

Table 9: Terminal allocation

| Terminal | Electrical          | LOK/LOR/LOS |
|----------|---------------------|-------------|
| 1        | Input               | L $\sim$    |
| 2        | Protective earth    | $\oplus$    |
| 3        | Input               | N $\sim$    |
| 4        | D/Output (positive) | D/+         |
| 5        | Output (positive)   | +           |
| 6        | Output (negative)   | -           |
| 7        | Output (negative)   | -           |
| 8        | R input or open     | R/n.c.      |

#### Standards and Approvals

The converters correspond to class I equipment. All models are UL recognized according to UL 1950, UL recognized for Canada to CAN/CSA C22.2 No. 950-95 and TÜV, approved to IEC/EN 60950 standards.

LOR and LOS are UL 508-listed components.

The converters have been evaluated for:

- Building in
- Double or reinforced insulation or an earthed part between input and output.
- Basic insulation between input and earth
- Functional insulation between output and earth
- The use in a pollution degree 2 environment
- Connecting the input to a primary circuit with overvoltage category II.

The converters are subject to manufacturing surveillance in accordance with the above mentioned standards.

For details see the Declaration of Conformity (last 2 pages).

#### Protection Degree

IP 20: All models.

Table 10: Isolation

| Characteristic                   |   | Input to protective earth | Input to output  | Output to protective earth | Unit       |
|----------------------------------|---|---------------------------|------------------|----------------------------|------------|
| Electric strength test voltage   | Actual factory test 1 s                           | 2.1                       | 2.1 <sup>1</sup> | 1.4                        | kVDC       |
|                                  | AC test voltage equivalent to actual factory test | 1.5                       | 1.5 <sup>1</sup> | 1.0                        | kVAC       |
| Insulation resistance at 500 VDC |   | >300                      | >300             | >100                       | M $\Omega$ |

<sup>1</sup> In accordance with EN 50116 and IEC/EN 60950 only subassemblies are pre-tested with 4.3 kVDC or 3.0 kVAC.

#### Installation Instructions

These converters are components, intended exclusively for inclusion within other equipment by an industrial assembly operation or by professional installers. Installation must strictly follow the national safety regulations in compliance with the enclosure, mounting, creepage, clearance, casualty, markings and segregation requirements of the end-use application.

Connection to the system shall be according to *Terminal allocation* and *Mechanical Data*. Check for hazardous voltages before altering any connection.

Ensure that a converter failure (e.g. by an internal short-circuit) does not result in a hazardous condition. See also *Safety of operator accessible output circuit*.

The phase input (L $\sim$ ) is internally fused by a 1.6 A slowblow type. It is not customer-accessible. This fuse is designed to protect the unit in case of overcurrent. Option F or external fuses in the wiring to one or both input pins (L $\sim$  and/or N $\sim$ ) may therefore be necessary to ensure compliance with local requirements.

A second fuse in the wiring to the terminal N $\sim$  is needed if:

- Local requirements demand an individual fuse in each source line
- Neutral and earth impedance is high or undefined
- Phase and neutral of the mains are not defined or cannot be assigned to the corresponding terminals (L $\sim$  to phase and N $\sim$  to neutral).

**Note:** Do not open the converters, or guarantee will be invalidated.

Make sure that there is sufficient air flow available for convection cooling. This should be verified by measuring the case temperature when the unit is installed and operated in the end-use application. The maximum specified case temperature  $T_{C\ max}$  shall not be exceeded.

#### Isolation

The electric strength test is performed as a factory test in accordance with IEC/EN 60950 and UL 1950 and should not be repeated in the field. Power-One will not honor any guarantee/warranty claims resulting from electric strength field tests.

**Caution:** Testing by applying AC voltages will result in high and dangerous leakage currents flowing through the Y-capacitors (see fig. *Block diagram*).

**Leakage Currents in AC-DC Operation**

Leakage currents flow due to internal leakage capacitance and RFI suppression Y-capacitors. The current values are proportional to the mains voltage and nearly proportional to the mains frequency and are specified at an input voltage of 264 V (50 Hz) where phase, neutral and protective earth are correctly connected as required for class I equipment.

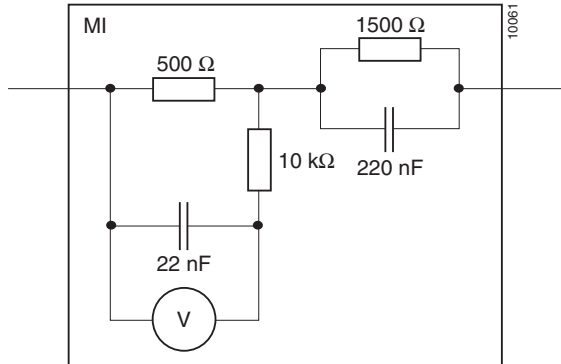

Fig. 10  
Measuring instrument (MI) for earth leakage current tests according to IEC/EN 60950.

Under test conditions the leakage current flows through a measuring instrument (MI) as described in fig. *Measuring instrument for earth leakage current tests*, which takes into account impedance and sensitivity of a person touching accessible parts. The current value is calculated by dividing the measured voltage by 500 W. If inputs and/or outputs of LOS, LOR, or LOK4000 models are connected in parallel, their individual leakage currents are added.

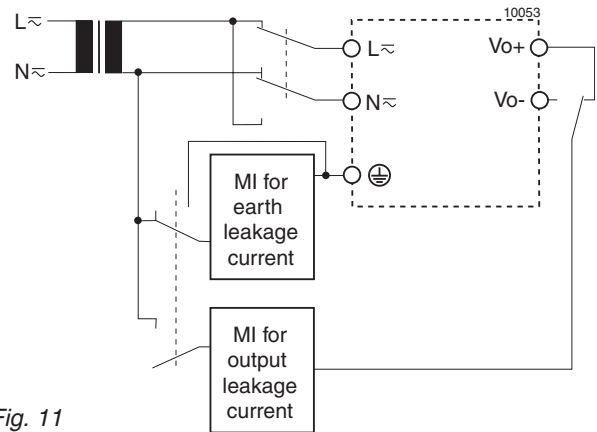

Fig. 11  
Test setup.

Table 11: Leakage currents

| Characteristic                 |                                       | LOK   | Unit |
|--------------------------------|---------------------------------------|-------|------|
| Maximum earth leakage current  | Permissible according to IEC/EN 60950 | 3.5   | mA   |
|                                | Specified value at 264 V, 50 Hz       | 1.0   |      |
| Maximum output leakage current | Permissible according to IEC/EN 60950 | 0.25  |      |
|                                | Specified value at 264 V, 50 Hz       | 0.035 |      |

**Safety of Operator Accessible Output Circuit**

If the output circuit of an AC-DC converter is operator accessible, it shall be a SELV circuit according to the IEC/EN 60950 related safety standards.

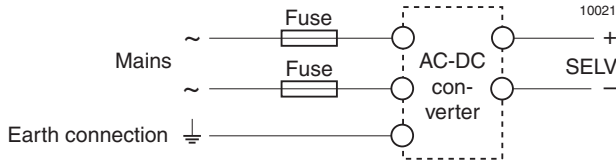

Fig. 12

Schematic safety concept.

Use fuses and earth connection as per *Installation Instructions* and table *Safety concept leading to a SELV output circuit*.

Table 12 : Safety concept leading to a SELV output circuit

| Conditions             | AC-DC converter   | Installation   | Result  |
|------------------------|---|--|---|
| Nominal Supply voltage | Grade of insulation between input and output, provided by the AC-DC converter | Measures to achieve the resulting safety status of the output circuit                | Safety status of the AC-DC converter output circuit |
| Mains ≤250 VAC         | Double or reinforced  | Earth connection <sup>1</sup> and installation according to the applicable standards | SELV circuit  |

<sup>1</sup> The earth connection of terminal no. 2 has to be provided by the installer according to the relevant safety standards, e.g. IEC/EN 60950

**Description of Options**

**Option F: Built-in Second Fuse**

A built-in second fuse in the neutral input line enables safe connection to the mains where phase and neutral are not defined or cannot be identified as e.g., in the case of plug and socket connection to the mains via Schuko-plugs, see also *Installation Instruction*.

**Option K: System Connectors**

For installation into systems using preassembled harnesses the converters are available with connectors fitted with screw terminals. The system connectors are UL-listed and approved for currents up to 10 A. Wire cross-sections: Solid wires 1.5 mm<sup>2</sup>, stranded wires 1 mm<sup>2</sup>.

NUCLEAR AND MEDICAL APPLICATIONS - Power-One products are not designed, intended for use in, or authorized for use as critical components in life support systems, equipment used in hazardous environments, or nuclear control systems without the express written consent of the respective divisional president of Power-One, Inc.

TECHNICAL REVISIONS - The appearance of products, including safety agency certifications pictured on labels, may change depending on the date manufactured. Specifications are subject to change without notice.

The following table shows a possible installation configuration, compliance with which causes the output circuit of an LOS, LOR, or LOK4000 converter to be a SELV circuit according to IEC/EN 60950 up to a configured output voltage (sum of nominal voltages if in series or +/- configuration) of 36 V.

However, it is the sole responsibility of the installer to assure the compliance with the relevant and applicable safety regulations.

## EC Declaration of Conformity

---

We

Power-One AG  
Ackerstrasse 56, CH-8610 Uster

declare under our sole responsibility that all **LOS/LOR series** AC-DC (DC-DC) converters carrying the CE-mark are in conformity with the provisions of the Low Voltage Directive (LVD) 73/23/EEC of the European Communities.

---

Conformity with the directive is presumed by conformity with the following harmonized standards:

- EN 61204: 1995 (= IEC 61204: 1993, modified)  
Low-voltage power supply devices, d.c. output - Performance characteristics and safety requirements
  - EN 60950: 2000 (= IEC 60950: 1999)  
Safety of information technology equipment.
- 

The installation instructions given in the corresponding data sheet describe correct installation leading to the presumption of conformity of the end product with the LVD. All these regulators are components intended exclusively for inclusion within other equipment by an industrial assembly operation or by professional installers. They must not be operated as stand alone products.

Hence conformity with the Electromagnetic Compatibility Directive 89/336/EEC (EMC Directive) needs not to be declared. Nevertheless, guidance is provided in most product application notes on how conformity of the end product with the indicated EMC standards under the responsibility of the installer can be achieved, from which conformity with the EMC directive can be presumed.

---

Uster, 1 Sept. 2005

Power-One AG

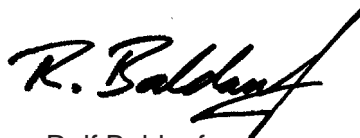

Rolf Baldauf  
Vicepresident Engineering



Johann Milavec  
Director Projects and IP

## EC Declaration of Conformity

---

We

Power-One AG  
Ackerstrasse 56, CH-8610 Uster

declare under our sole responsibility that all **LOK series** AC-DC (DC-DC) converters carrying the CE-mark are in conformity with the provisions of the Low Voltage Directive (LVD) 73/23/EEC of the European Communities.

---

Conformity with the directive is presumed by conformity with the following harmonized standards:

- EN 61204: 1995 (= IEC 61204: 1993, modified)  
Low-voltage power supply devices, d.c. output - Performance characteristics and safety requirements
  - EN 60950-1: 2001 (= IEC 60950-1: 2001)  
Safety of information technology equipment.
- 

The installation instructions given in the corresponding data sheet describe correct installation leading to the presumption of conformity of the end product with the LVD. All these regulators are components intended exclusively for inclusion within other equipment by an industrial assembly operation or by professional installers. They must not be operated as stand alone products.

Hence conformity with the Electromagnetic Compatibility Directive 89/336/EEC (EMC Directive) needs not to be declared. Nevertheless, guidance is provided in most product application notes on how conformity of the end product with the indicated EMC standards under the responsibility of the installer can be achieved, from which conformity with the EMC directive can be presumed.

---

Uster, 1 Sept. 2005

Power-One AG

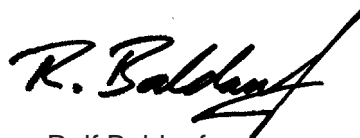

Rolf Baldauf  
Vicepresident Engineering



Johann Milavec  
Director Projects and IP