

# USER GUIDE AND TERMINAL BLOCK SPECIFICATIONS

# NI PXIe-4304/4305 and RM-4304

NI PXIe-4304/4305, 32 Ch, 24-bit, Filtered Analog Input Module, RM-4304 Rack-Mount Terminal Block

Français    Deutsch    日本語    한국어    简体中文  
[ni.com/manuals](http://ni.com/manuals)

This document explains how to install, configure, and set up the NI PXIe-4304 and NI PXIe-4305 (NI PXIe-4304/4305) simultaneous filtered modules with the RM-4304 rack-mount terminal blocks. Driver support for the PXIe-4304/4305 was first available in NI-DAQmx 15.1.1. Driver support for the RM-4304 was first available in NI-DAQmx 15.5. For the list of devices supported by a specific release, refer to the *NI-DAQmx Readme*, available on the version-specific download page or installation media.



**Note** The keying of this terminal block prevents it from connecting to other modules that could be damaged by the voltage present on the terminal block. However, you should only use these terminal blocks with their supported modules.

## Contents

Electromagnetic Compatibility Guidelines .....	2
What You Need to Get Started .....	3
Installation .....	4
Install the Software .....	4
Unpack and Install the Module .....	4
Unpack and Install the Rack-Mount Terminal Block, Chassis, and Cables .....	6
CAL IN .....	10
CAL BIAS .....	10
In-Situ Calibration .....	11
Resources .....	12
RJ50 .....	13
Status LED .....	13
PFIO .....	14
Switching .....	14
Confirm SC Express Module Recognition .....	14
Run Test Panels .....	16

Take an NI-DAQmx Measurement.....	16
NI-DAQmx Channels and Tasks .....	16
Configure a Task Using the DAQ Assistant in MAX .....	16
Use Your SC Express Device in an Application .....	17
Programming Examples.....	17
Removal.....	18
Terminal Block and Cables Removal .....	18
Module Removal.....	18
Create a Simulated Device.....	19
More Information.....	20
Troubleshooting .....	20
Specifications (RM-4304).....	20
Electrical .....	20
Input Characteristics .....	20
Mechanical.....	21
Connectors .....	21
Physical Characteristics .....	21
Environmental.....	22
Operating Environment.....	22
Storage Environment .....	22
Shock and Vibration .....	22
Safety .....	23
Safety Standards .....	23
Electromagnetic Compatibility.....	23
CE Compliance.....	24
Online Product Certification.....	24
Environmental Management.....	24
World Wide Support and Services.....	25

## Electromagnetic Compatibility Guidelines

---

This product was tested and complies with the regulatory requirements and limits for electromagnetic compatibility (EMC) stated in the product specifications. These requirements and limits provide reasonable protection against harmful interference when the product is operated in the intended operational electromagnetic environment.

This product is intended for use in industrial locations. However, harmful interference may occur in some installations, when the product is connected to a peripheral device or test object, or if the product is used in residential or commercial areas. To minimize interference with radio and television reception and prevent unacceptable performance degradation, install and use this product in strict accordance with the instructions in the product documentation.

Furthermore, any modifications to the product not expressly approved by National Instruments could void your authority to operate it under your local regulatory rules.



**Caution** To ensure the specified EMC performance, operate this product only with shielded cables and accessories. Shielded, twisted pair cable must be used for all RJ-50 ports and the CAL IN port.



**Caution** To ensure the specified EMC performance, the length of any cable connected to the PFI0 port must be no longer than 3 m (10 ft).



**Caution** To ensure the specified EMC performance, the length of any cable connected to the Channel (RJ-50) ports must be no longer than 30 m (100 ft).

## What You Need to Get Started

---

To set up and use the RM-4304 rack-mount terminal block with the PXIe-4304/4305 module, you need the following items:

- Hardware
  - RM-4304 rack-mount terminal block
  - PXIe-4304/4305 module
  - PXIe chassis
  - 19 in. rack to accommodate the RM-4304 and PXIe chassis
  - Four screws (not supplied by NI) suitable for your application to mount the RM-4304 in the rack
  - SH96F-96M-42V cable and included standoffs, which are used to mount the cable to the module
  - Rack-mount kit (as required for your application) for mounting the PXIe chassis in the 19 in. rack
  - Cabling and sensors as required for your application
  - Clamp-on ferrite beads (included with RM-4304)
- Tools
  - Phillips-head screwdrivers as required by your application
  - Flathead screwdrivers as required by your application
  - Long-nose pliers
  - Wire cutter
  - Wire insulation stripper
  - RJ50 terminal crimper
- Documentation
  - NI PXIe-4304/4305 and RM-4304 User Guide and Terminal Block Specifications
  - *NI PXIe-4304/4305 User Manual*
  - PXIe chassis user manual

You can download needed documents from [ni.com/manuals](https://ni.com/manuals).

# Installation

---

## Install the Software



**Note** You must be an administrator to install NI software and devices on your computer.

Ensure that the following software is installed before installing the SC Express hardware:

1. Your application software, such as LabVIEW, LabWindows™/CVI™ or .NET.
2. NI-DAQmx—PXIe-4304/4305 modules were first supported in NI-DAQmx 15.1.1. RM-4304 terminal blocks were first supported in NI-DAQmx 15.5.



**Note** For detailed NI software version support, refer to the *NI-DAQmx Readme*. Back up any applications before upgrading software or modifying the application.

## Unpack and Install the Module

Remove the packaging and inspect the module. Contact NI if the module is damaged. Do not install a damaged module.



**Caution** The module is static sensitive. Always properly ground yourself and the equipment when handling or connecting to the module.

Complete the following steps to install the SC Express module while referring to Figures 1 and 2:



**Note** To maintain forced air cooling in the PXIe system, refer to the *Maintain Forced-Air Cooling* document.

1. Make sure the chassis is powered off.
2. Connect the power cord to your chassis and then plug it into the power supply receptacle before installing the PXIe-4304/4305. The power cord grounds the chassis and protects it from electrical damage while you install the module.



**Caution** To protect yourself, the chassis, and the PXIe-4304/4305 from electrical hazards, leave the chassis powered off until you complete the PXIe-4304/4305 module installation.

3. Identify a supported PXI Express slot in the chassis. SC Express devices can be placed only in PXI Express Peripheral slots, PXI Express Hybrid Peripheral slots, and PXI Express System Timing slots. Refer to the chassis documentation for details.

**Figure 1.** Symbols for PXI Express/PXI Express Hybrid/PXI Slots

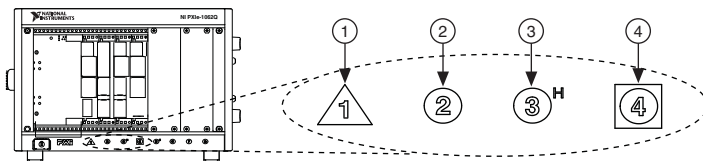

- |                                      |                                      |
|--------------------------------------|--------------------------------------|
| 1 PXI Express System Controller Slot | 3 PXI Express Hybrid Peripheral Slot |
| 2 PXI Peripheral Slot                | 4 PXI Express System Timing Slot     |

4. Remove the filler panel, and touch any metal part of the chassis to discharge static electricity.
5. Place the module edges into the module guides at the top and bottom of the slot.



**Caution** When installing the module, make sure both edges are positioned inside the guides and that the module components do not come into contact with adjacent modules.

6. Slide the module along the guides until it reaches the rear connector then seat the module by pushing the front panel until it is flush with the front panel of the chassis.
7. Secure the module to the chassis using the front-panel captive screws, shown in Figure 2. Tighten the screws to 0.31 N · m (2.7 lb · in.).

**Figure 2.** Installing PXIe-4304/4305 Modules

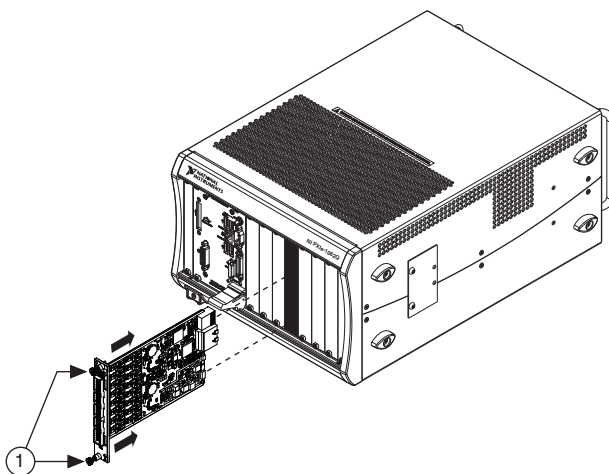

- 1 Captive Screws

# Unpack and Install the Rack-Mount Terminal Block, Chassis, and Cables

Remove the packaging and inspect the terminal block, chassis, and cables. Contact NI if there is any damage. Do not install a damaged product.



**Caution** The module and terminal block are static sensitive. Always properly ground yourself and the equipment when handling or connecting to the module and terminal block.



**Caution** Do not supply hazardous voltages ( $>30 V_{\text{rms}}/42.4 V_{\text{pk}}/60 \text{ VDC}$ ) to the terminal block.



**Caution** To ensure the EMC performance specified for the connected PXIe-4304/4305 module, operate this product only with shielded RJ50 and BNC cables.



**Note** The chassis can be powered on or off when connecting the terminal block.

To install the rack-mount terminal block into the rack, complete the following steps while referring to Figure 3.

1. Place the RM-4304 in the desired position.
2. Install and tighten the four rack-mounting screws.

If the chassis is not already installed in the rack, complete the following steps:

1. Attach the PXIe chassis rack-mount hardware to the PXIe chassis. Refer to your rack-mount kit installation guide for more details.
2. Mount the PXIe chassis in the rack in the desired position. Refer to your rack-mount kit installation guide for more details.

**Figure 3. RM-4304 Installation and Front Connections**

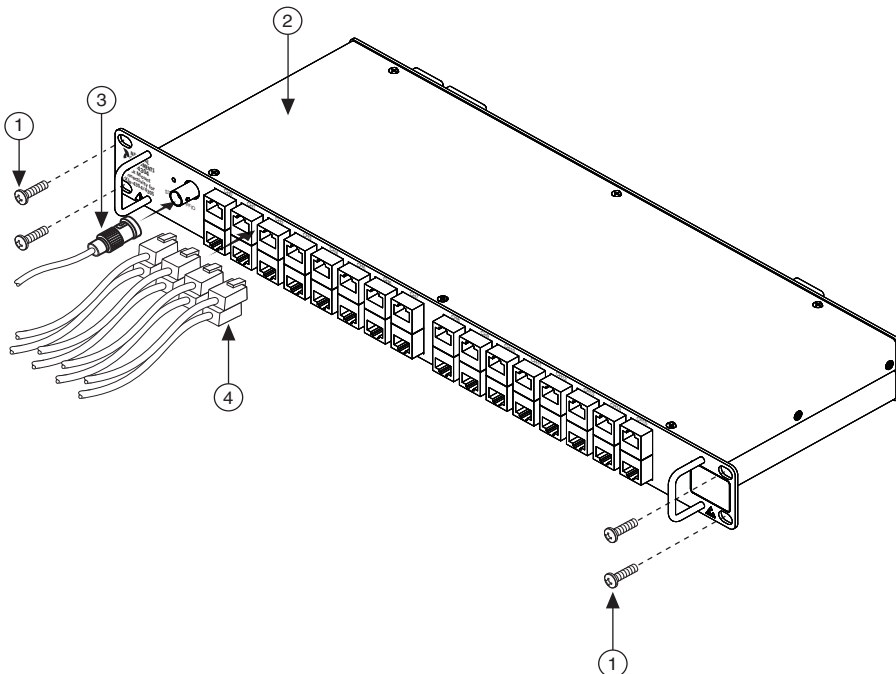

---

1	Rack-Mounting Screws (4)	3	PFI BNC Cable
2	RM-4304 Rack-Mount Terminal Block	4	RJ50 (32) Cable Connectors

---

To install the cables, complete the following steps while referring to Figures 3 and 6.

1. Connect the RJ50 cable connectors to the appropriate RJ50 connector receptacles. Refer to the [RJ50](#) section for more information.
2. Make any of the following connections as needed for your application:
  - Connect the BNC cable to the PF10 receptacle.
  - Connect calibration input.
    - a. Remove the 2-pin CAL IN COMBICON connector from the RM-4304.
    - b. Install the calibrator input wires. Refer to the [In-Situ Calibration](#) section for more information.

- c. Connect the CAL IN cable shield to AIGND, Pin 2 and 3 of CAL BIAS Connector, as shown in Figure 4.

**Figure 4. CAL BIAS Cable Connections**

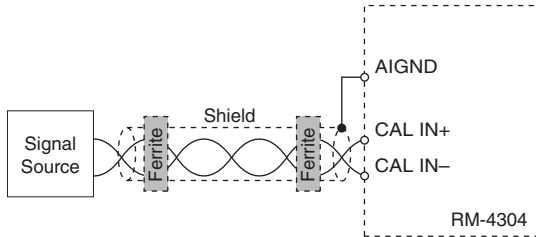

- d. For CAL IN cable lengths greater than 3 meters, install the included clamp-on ferrite beads on both ends of the CAL IN cable. Refer to Figure 5 to install the clamp-on ferrite beads.



**Note** Clamp-on ferrite beads must be installed on the cable as close to the RM-4304 and to the source as possible. Placing the clamp-on ferrite beads elsewhere on the cable noticeably impairs its effectiveness.

**Figure 5. Clamp-On Ferrite Bead Installation**

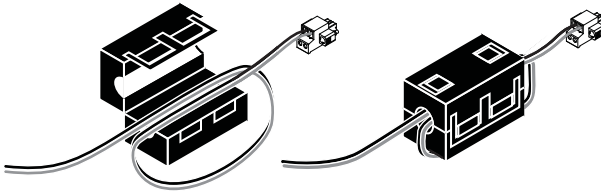

- e. Install the 2-pin CAL IN COMBICON cable into the RM-4304.
- Connect the calibration bias resistors.
  - a. Remove the 4-pin RB1, RB2 COMBICON connector from the RM-4304.
  - b. Install the bias resistors. Refer to the [CAL IN](#) section for more information.
  - c. Install the 4-pin RB1, RB2 COMBICON cable into the RM-4304.



3. Connect the chassis ground wire to the chassis ground screw.

**Figure 6. Cables, Resistor, and Standoff Installation**

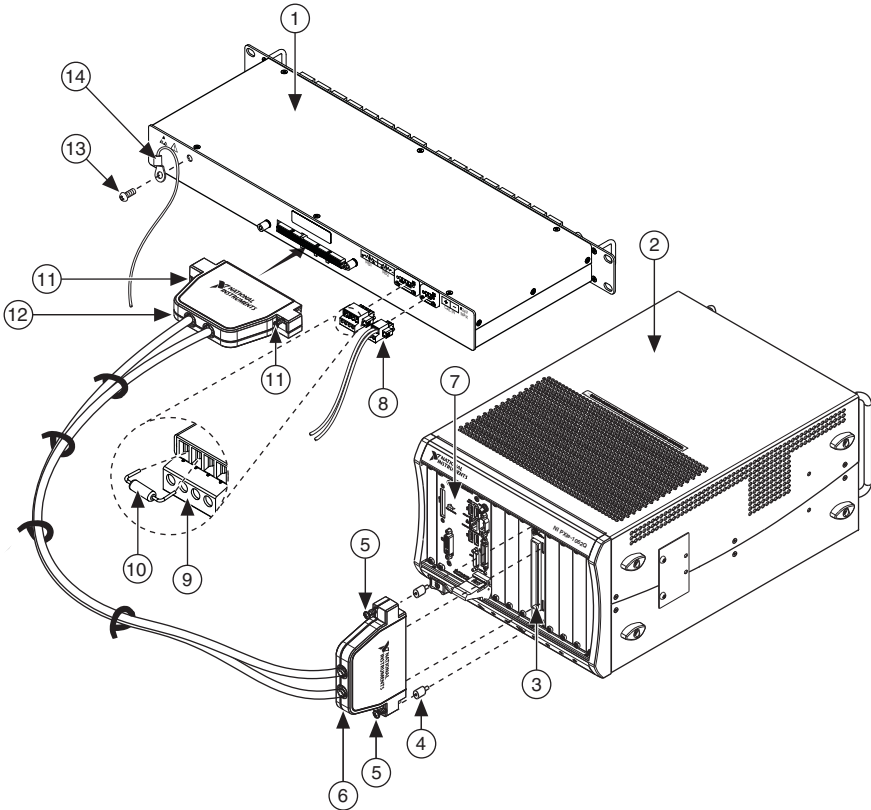

- |   |   |
|---|---|
| 1 RM-4304 Rack-Mount Terminal Block                   | 9 Calibration Bias Resistor Connector 4-position COMBICON |
| 2 PXIe Chassis  | 10 Bias Resistor  |
| 3 PXIe-4304/4305 Module                               | 11 Jack Screws (2x)                                       |
| 4 Standoffs (2)                                       | 12 SH96F-96M-42V Cable RM-4304 Connector Plug (male)      |
| 5 Jack Screws (2x)                                    | 13 Chassis Ground Screw                                   |
| 6 SH96F-96M-42V Cable RM-4304 Connector Plug (female) | 14 Chassis Ground Cable                                   |
| 7 PXIe Controller                                     |   |
| 8 Calibration Input 2-position COMBICON Cable         |   |

4. Screw the two standoffs into the PXIe-4304/4305 module. Tighten the standoffs to 1.30 N · m (11.5 lb · in.).
5. Connect the male end of the SH96F-96M-42V cable to the RM-4304 and tighten the two jack screws to 0.90 N · m (8.0 lb · in.).



**Note** For safety purposes and to prevent damage to equipment when high voltages are present, the SH96F-96M-42V cable is keyed to prevent connection between incompatible terminal blocks, modules, and/or cables.

6. Connect the female end of the SH96F-96M-42V cable to the PXIe-4304/4305 and tighten the two jack screws to 0.90 N · m (8.0 lb · in.).
7. Power on the PXIe chassis if it is powered off.

## CAL IN

The CAL IN input connector on the rear of the RM-4304 allows you to connect a voltage reference that can be internally routed to the analog input of each channel (AI+, AI-) on the PXIe-4304/4305. All channels are simultaneously switched to the CAL IN by utilizing the Calibration API within NI-DAQmx. Refer to the [In-Situ Calibration](#) section for detailed information.

The calibration source voltage is connected to the CAL IN+ and CAL IN- terminals as shown in Table 1.

**Table 1.** Calibration Input Connector Pin Assignments

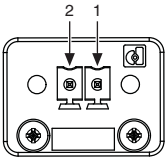
Calibration Input Pin Diagram	Pin	Signal Name	Signal Description
	1	CAL IN-	Calibration input negative
	2	CAL IN+	Calibration input positive

## CAL BIAS

You can use the connector labeled RB1 and RB2 on the rear of the RM-4304 to reference the CAL± input to analog ground (AIGND). For flexibility, access to both CAL+ and CAL- is provided. The CAL BIAS+ pin connects to CAL+ and the CAL BIAS- pin connects to CAL-. You can reference a floating voltage to AIGND by populating the RB1 position. To provide a differential voltage that is referenced to AIGND with zero common mode, populate both RB1 and RB2 with equal value resistors. When choosing resistor values, consider the output impedance of the external reference voltage source. Refer to Table 2 for connections.

**Table 2.** Bias Resistor Connector

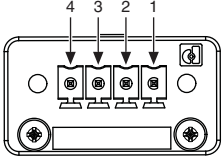
Bias Resistor Connector	Pin	Signal Name	Signal Description
	1	CAL BIAS-	RB2 calibration bias resistor for CAL-
	2	AIGND	Analog input ground
	3	AIGND	Analog input ground
	4	CAL BIAS+	RB1 calibration bias resistor for CAL+

## In-Situ Calibration

The RM-4304 provides the ability to perform in-situ calibration of input channels referenced to an external traceable voltage source that you can use to connect to the CAL IN connector. In-situ calibration offers a means to determine measurement errors and uncertainties compared to a traceable standard. The calibration data can be used to compensate for changes in the hardware, resulting in a more accurate measurement. In-situ calibration can be performed before and after test acquisition, or on a periodic schedule, to ensure data validity without physically disconnecting any inputs from the RM-4304.

During in-situ calibration, the input channels are disconnected internally from the RJ50 connectors and connected to a calibration bus that is driven by the calibration voltage reference connected to CAL IN±. Through measurement of these channels, any PXIe-4304/4305 circuitry drift since the last full calibration will be available through measurement of these channels. In-situ calibration performs a verification, but not an adjustment. Therefore, the results from in-situ calibration will not rewrite the calibration coefficients to the PXIe-4304/4305. Instead these results can be applied to the test setup, test results, or to the PXIe-4304/4305 programmatically.

To assist you with starting development of an application with in-situ calibration, an example program is available for download from the NI Community. Refer to [ni.com/info](http://ni.com/info) and enter Info Code `exsueg`.

For in-situ calibration, the following connection options are supported through NI-DAQmx as shown in Table 3.

**Table 3.** Connection Options Configurable Through NI-DAQmx Connect SC Express Calibration Accessory Channels API

Connection Option	Purpose
<code>_cal_channel</code>	Connect a voltage reference provided through CAL IN to the analog input of each channel.

# Resources

This section describes the resources available on both the front and rear of the RM-4304. Figure 7 shows the locations of these resources.

**Figure 7. RM-4304 Front and Rear View**

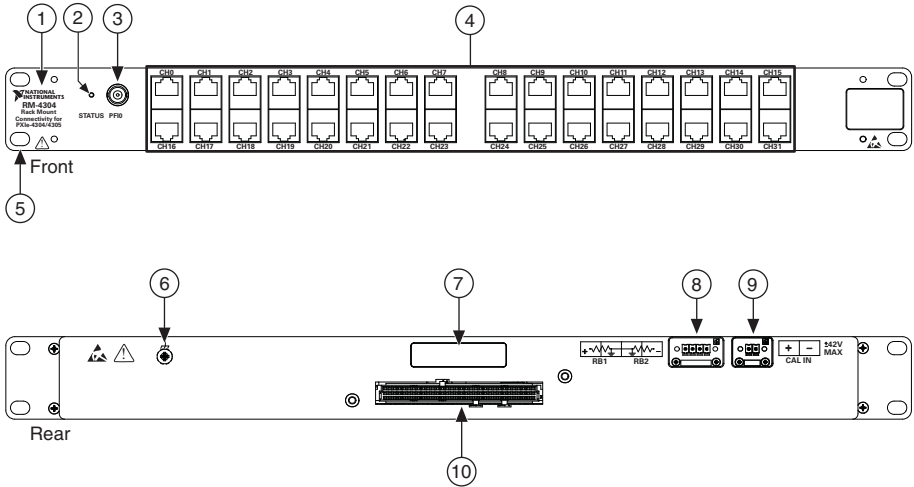

- |                         |   |
|-------------------------|---|
| 1 RM-4304 Product Name  | 7 Serial Number Label                                     |
| 2 LED Status Indicator  | 8 Calibration Bias Resistor Connector 4-position COMBICON |
| 3 PFIO                  | 9 Calibration Input 2-position COMBICON                   |
| 4 RJ50 Connectors (32)  | 10 96-Pin DIN Cable Connector                             |
| 5 Mounting Flanges (2x) |   |
| 6 Chassis Ground        |   |

## RJ50

Refer to Table 4 for signal names and descriptions, and the correlation to the pin numbers of the RJ50 (10p10c) modular plug. Refer to Figure 8 for default switch positions.

**Table 4.** RJ50 Connector Pin Assignments

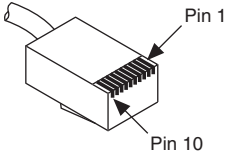
RJ50* (10p10c) Modular Plug Pin Number Diagram	Pin	Signal Name	Signal Description
	1	NC	No connection.
	2	AI+	Positive input signal—connected to the AI+ input of the PXIe-4304/4305 or disconnected when the channel is connected to CAL_IN+
	3	AI-	Negative input signal—connected to the AI- input of the PXIe-4304/4305 or disconnected when the channel is connected to CAL_IN-
	4	NC	No connection.
	5	NC	No connection.
	6	NC	No connection.
	7	NC	No connection.
	8	NC	No connection.
	9	AIGND	Analog ground.
	10	NC	No connection.
<p>* NI does not recommend using an RJ45 cable with the RM-4304 as it can physically damage pins 1 and 10 on the RJ50 connector.</p> <p><b>Note:</b> Use pins 2 and 3 as shielded pairs.</p> <p><b>Note:</b> Refer to Figure 8 for default positions</p>			

## Status LED

The green status LED, when lit, indicates the RM-4304 is connected to a powered PXIe-4304/4305 module. The location of the Status LED is shown in Figure 7.

# PFIO

The PFIO connector provides a female BNC connection to the PFI trigger line of the PXIe-4304/4305. The RM-4304 passes this signal directly through. Refer to the *NI PXIe-4304/4305 User Manual* for more information about using the PFI trigger line. Refer to Table 5 for signal names and descriptions.

**Table 5.** BNC Connector Pin Assignments

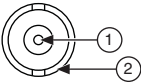
BNC PFIO Connector Pin Diagram	Pin	Signal Name	Signal Description
	1	PFIO	PFI input
	2	DGND	Digital ground

## Switching

The RM-4304 provides software controlled switching that allows you to programmatically control whether the attached PXIe-4304/4305 is connected to the CAL IN source on the back of the RM-4304 or the RJ50 connectors on the front of the RM-4304. Figure 8 illustrates the switching provided.

**Figure 8.** RM-4304 Switching Configurations

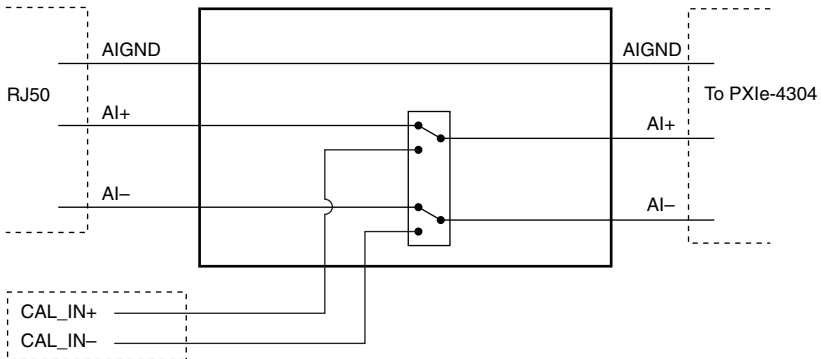

## Confirm SC Express Module Recognition

To confirm module recognition, complete the following steps:



**Note** Software support for the PXIe-4304/4305 is provided by NI-DAQmx. The *Read Me First: NI-DAQmx and DAQ Device Installation Guide*, which you can download at [ni.com/manuals](http://ni.com/manuals), offers step-by-step NI-DAQmx instructions for installing software and hardware, configuring channels and tasks, and getting started developing an application. For detailed NI software version support, refer to the *NI-DAQmx Readme*.

1. Launch MAX.



2. Expand **Devices and Interfaces**, and expand the chassis in which the module is located to confirm that MAX detects the module and terminal block. The terminal block should appear beneath its associated module. If your module or terminal block is not listed, press <F5> to refresh MAX. If the module is still not recognized, go to [ni.com/support/daqmx](https://ni.com/support/daqmx).

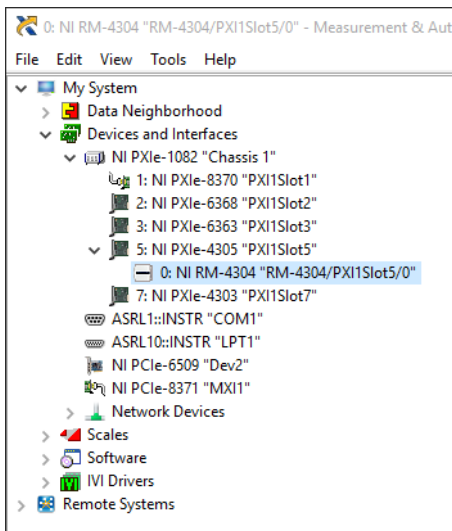

**Tip** Using an NI-DAQmx simulated device, you can test NI-DAQmx applications without installing hardware. Refer to the [Create a Simulated Device](#) section for instructions for creating NI-DAQmx simulated devices.

3. Right-click the module name and select **Self-Test**. When the self-test completes, a verification message appears. If an error occurs, refer to [ni.com/support/daqmx](https://ni.com/support/daqmx).

For information about sensors, go to [ni.com/sensors](https://ni.com/sensors).

# Run Test Panels

1. In MAX, expand **Devices and Interfaces** select the chassis in which the module is located.
2. Right-click the device, and select **Test Panels**.

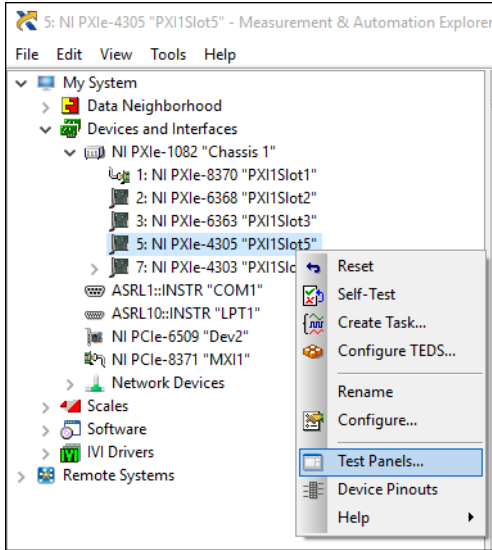

3. Click **Start** to test device functions, or **Help** for operating instructions.

To troubleshoot errors, refer to the *NI-DAQmx Help*, or go to [ni.com/support](http://ni.com/support).

## Take an NI-DAQmx Measurement

### NI-DAQmx Channels and Tasks

Refer to the *NI-DAQmx Help* for complete information about channels and tasks.

Use the DAQ Assistant to configure virtual channels and tasks in MAX or in your application.

### Configure a Task Using the DAQ Assistant in MAX

Complete the following steps to create a task using the DAQ Assistant in MAX:

1. In MAX, right-click **Data Neighborhood** and select **Create New** to open the DAQ Assistant.
2. Select **NI-DAQmx Task** and click **Next**.
3. Select **Acquire Signals**.
4. Select **Analog Input**, and the measurement type, such as **Voltage**.
5. Select the physical channel(s) to use and click **Next**.



6. Name the task and click **Finish**.
7. Configure the individual channel settings. Each physical channel you assign to a task receives a virtual channel name. To modify the input range or other settings, select the channel. Click **Details** for physical channel information. Configure the timing and triggering for your task. Click **Run**.

## Use Your SC Express Device in an Application

For NI software version compatibility, refer to the NI-DAQmx Readme, available from **Start»All Programs»National Instruments»NI-DAQmx**.

To get started with data acquisition in your application software, refer to the tutorials listed in Table 6.

**Table 6.** DAQ Assistant Tutorial Locations

<b>Application</b>	<b>Tutorial Location</b>
LabVIEW	Go to <a href="http://ni.com/dataacquisition/videos">ni.com/dataacquisition/videos</a> .
LabWindows/CVI	Go to <b>Help»Contents</b> . Next, go to <b>Using LabWindows/CVI»Data Acquisition»Taking an NI-DAQmx Measurement in LabWindows/CVI</b> .
Measurement Studio	Go to <b>NI Measurement Studio Help»Getting Started with the Measurement Studio Class Libraries»Measurement Studio Walkthroughs»Walkthrough: Creating a Measurement Studio NI-DAQmx Application</b> .
NI SignalExpress*	Go to <b>Help»Taking an NI-DAQmx Measurement in SignalExpress</b> .
* NI SignalExpress, an easy-to-use configuration-based tool for data logging applications, is at <b>Start»All Programs»National Instruments»NI SignalExpress</b> .	

## Programming Examples

NI-DAQmx includes example programs to help you get started developing an application. LabVIEW and CVI examples are located at **Help»Find Examples** in your application software. Text-based code examples are located at **All Programs»National Instruments»NI-DAQmx»NI-DAQmx Examples**. Modify example code and save it in an application, or use examples to develop a new application or add example code to an existing application.

For other examples, go to [ni.com/info](http://ni.com/info) and enter the Info Code `daqmxexp`. For additional examples, refer to [ni.com/support](http://ni.com/support).

# Removal

---

## Terminal Block and Cables Removal

To remove the RM-4304 and PXIe-4304/4305, complete the following steps while referring to Figures 3 and 6:



**Note** The chassis can be powered on or off when removing the terminal block.

1. Remove the RJ50 connector cables from the terminal block.
2. Remove any of the following connections as needed for your application:
  - Disconnect the BNC cable from the PFI0 receptacle.
  - Disconnect the 4-pin calibration bias resistor connector from the 4-pin bias resistor receptacle.
  - Disconnect the 2-pin CAL IN connector from the 2-pin CAL IN receptacle.
  - Disconnect ground wire from the ground screw.
3. Loosen the four jack screws and remove the SH96F-96M-42V cable from the terminal block and the module.



**Note** If required for your application, remove the two standoffs from the module.

4. While supporting the terminal block, remove the four rack-mounting screws.
5. Remove the terminal block from the rack.
6. Store the terminal block in an antistatic protective bag.

## Module Removal



**Caution** Do *not* remove a PXIe-4304/4305 module with the PXIe chassis powered on. Doing so can damage the module.

To remove the PXIe-4304/4305 module, refer to Figure 9 while completing the following steps:



**Note** To maintain forced air cooling in the PXIe system, refer to the *Maintain Forced-Air Cooling* document.

1. Make sure that the chassis is powered off before removing the module.
2. Loosen the captive screws on the top and bottom of the module.



**Caution** Do *not* pull the front panel to remove the module. Doing so may cause module components to come into contact with adjacent modules, causing damage to the modules.

3. Pull the captive screws to unseat the module and slowly slide the module along the guides.
4. Replace the filler panel in the empty slot.
5. Store the module in an antistatic protective bag.

**Figure 9.** Removing SC Express Modules

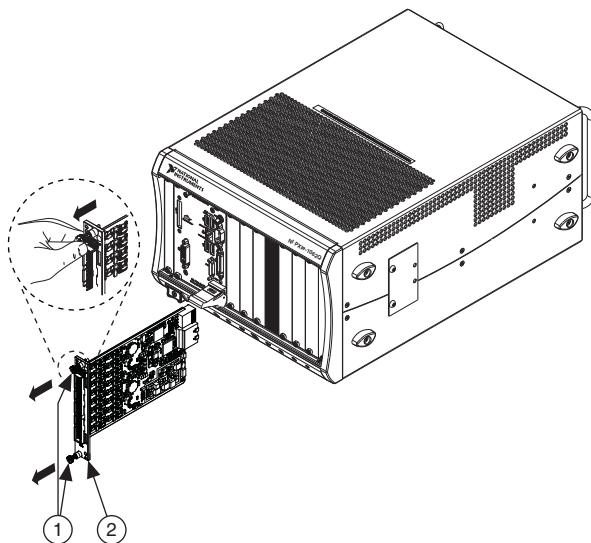

1 Captive Screws (Use to remove modules.)

2 Front Panel (Do not use to remove modules.)

## Create a Simulated Device

To run examples without the hardware installed, use an NI-DAQmx simulated device. To create a simulated device in MAX:

1. Launch MAX.
2. Right-click **Devices and Interfaces»Create New**.
3. From the dialog, select **Simulated NI-DAQmx Device or Modular Instrument**.
4. Type 4304 or 4305 in the text box at the top of the window.
5. Select the device from the list provided.
6. Click **OK**.
7. To simulate an accessory:
  - a. Right-click the simulated PXIe-4304 (or PXIe-4305)»**Configure...**
  - b. Select the Accessory from the Connector 0 drop down.
  - c. Click **OK**.

# More Information

---

After you install NI-DAQmx, the NI-DAQmx documentation is available from **Start» All Programs»National Instruments»NI-DAQ**. Additional resources are online at [ni.com/gettingstarted](http://ni.com/gettingstarted).

You can access online device documentation by right-clicking your module in MAX and selecting **Help»Online Device Documentation**. A browser window opens to [ni.com/manuals](http://ni.com/manuals) with the results of a search for relevant documents. If you do not have Web access, documents for supported modules are included on the NI-DAQmx media.

## Troubleshooting

- Go to [ni.com/support/install](http://ni.com/support/install) or [ni.com/kb](http://ni.com/kb).
- If you need to return your National Instruments hardware for repair or device calibration, go to [ni.com/info](http://ni.com/info) and enter `rdseenn` to start the Return Merchandise Authorization (RMA) process.

## Specifications (RM-4304)

---



**Note** PXIe-4304/4305 module specifications are located in the *NI PXIe-4304/4305 Specifications* document.

All specifications are typical for the range of 0 °C to 55 °C unless otherwise specified.

## Electrical

Input voltage range ..... Refer to the *NI PXIe-4304/4305 Specifications* document.

## Input Characteristics

Number of channels ..... 32 analog input channels

AI± differential input

Range ..... Refer to the *NI PXIe-4304/4305 Specifications* document

Offset voltage<sup>1</sup> ..... 10 µV max @ 23 °C ±5 °C  
4 µV typ @ 23 °C ±5 °C

Offset voltage stability ..... 0.5 µV/°C max  
0.05 µV/°C

---

<sup>1</sup> The offset voltage specification of the RM-4304 is an additional offset error that should be added to the offset error of the PXIe-4304/4305 to determine the total system offset error.

AI± to CAL± offset matching.....	2 $\mu$ V
CAL IN.....	$\pm$ 42 V
RB1, RB2.....	application specific

## Mechanical

### RJ50 receptacle

Mean number of insertions before failure.....	500
--	-----

### Channel configuration switches

Switch type ..... Electromechanical relay, latching

### Expected switch life

Mechanical.....	$5 \times 10^7$ cycles
Electrical.....	$2 \times 10^5$ cycles

## Connectors

RJ50.....	32
BNC.....	1
96-pin DIN.....	1
COMBICON 2 position.....	1
COMBICON 4 position.....	1

## Physical Characteristics

**Figure 10. RM-4304 Dimensions**

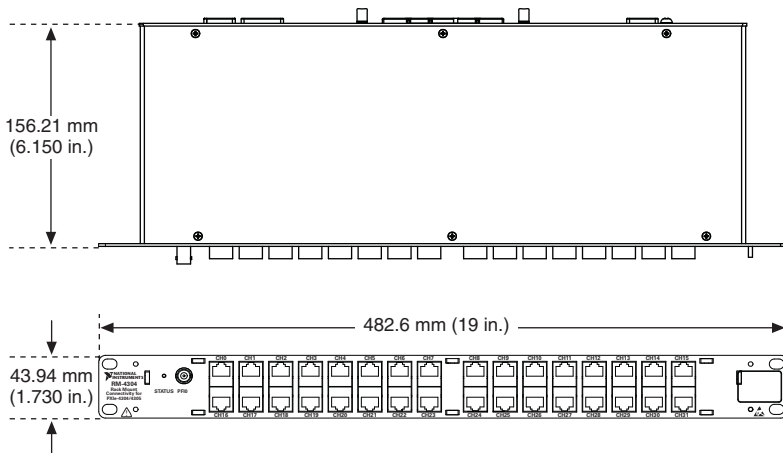

Weight ..... 1575 g (55.6 oz)



**Caution** Clean the hardware with a soft, nonmetallic brush. Make sure that the hardware is completely dry and free from contaminants before returning it to service.

## Environmental

Maximum altitude ..... 2,000 m (800 mbar), at 25 °C ambient temperature

Pollution Degree ..... 2

Indoor use only

## Operating Environment

Ambient temperature range ..... 0 °C to 55 °C  
(Tested in accordance with IEC 60068-2-1 and IEC 60068-2-2. Meets MIL-PRF-28800F Class 3 low temperature limit and MIL-PRF-28800F Class 2 high temperature limit.)

Relative humidity range ..... 10% to 90%, noncondensing  
(Tested in accordance with IEC 60068-2-56.)

## Storage Environment

Ambient temperature range ..... -40 °C to 71 °C  
(Tested in accordance with IEC 60068-2-1 and IEC 60068-2-2. Meets MIL-PRF-28800F Class 3 limits.)

Relative humidity range ..... 5% to 95%, noncondensing  
(Tested in accordance with IEC 60068-2-56.)

## Shock and Vibration

Operating shock ..... 30 g peak, half-sine, 11 ms pulse  
(Tested in accordance with IEC 60068-2-27. Meets MIL-PRF-28800F Class 2 limits.)

Random vibration

Operating ..... 5 Hz to 500 Hz, 0.3  $g_{rms}$

Non-operating ..... 5 Hz to 500 Hz, 2.4  $g_{rms}$   
(Tested in accordance with IEC 60068-2-64. Non-operating test profile exceeds the requirements of MIL-PRF-28800F, Class 3.)

# Safety

Measurement Category..... I<sup>1</sup>



**Caution** Do *not* connect the RM-4304 to signals or use for measurements within Measurement Categories II, III, or IV.



**Caution** The protection provided by the RM-4304 can be impaired if it is used in a manner not described in this document.

## Safety Standards

This product meets the requirements of the following standards of safety for electrical equipment for measurement, control, and laboratory use:

- IEC 61010-1, EN 61010-1
- UL 61010-1, CSA 61010-1



**Note** For UL and other safety certifications, refer to the product label or the [Online Product Certification](#) section.

## Electromagnetic Compatibility

---

This product meets the requirements of the following EMC standards for electrical equipment for measurement, control, and laboratory use:

- EN 61326-1 (IEC 61326-1): Class A emissions; Basic immunity
- EN 55011 (CISPR 11): Group 1, Class A emissions
- EN 55022 (CISPR 22): Class A emissions
- EN 55024 (CISPR 24): Immunity
- AS/NZS CISPR 11: Group 1, Class A emissions
- AS/NZS CISPR 22: Class A emissions
- FCC 47 CFR Part 15B: Class A emissions
- ICES-001: Class A emissions



**Note** In the United States (per FCC 47 CFR), Class A equipment is intended for use in commercial, light-industrial, and heavy-industrial locations. In Europe, Canada, Australia and New Zealand (per CISPR 11) Class A equipment is intended for use only in heavy-industrial locations.

---

<sup>1</sup> Measurement Categories CAT I and CAT O are equivalent. These test and measurement circuits are not intended for direct connection to the MAINS building installations of Measurement Categories CAT II, CAT III, or CAT IV.



**Note** Group 1 equipment (per CISPR 11) is any industrial, scientific, or medical equipment that does not intentionally generate radio frequency energy for the treatment of material or inspection/analysis purposes.



**Note** For the standards applied to assess the EMC of this product, refer to the [Online Product Certification](#) section.

## CE Compliance

This product meets the essential requirements of applicable European Directives as follows:

- 2014/35/EU; Low-Voltage Directive (safety)
- 2014/30/EU; Electromagnetic Compatibility Directive (EMC)

## Online Product Certification

Refer to the product Declaration of Conformity (DoC) for additional regulatory compliance information. To obtain product certifications and the DoC for this product, visit [ni.com/certification](http://ni.com/certification), search by model number or product line, and click the appropriate link in the Certification column.

## Environmental Management

NI is committed to designing and manufacturing products in an environmentally responsible manner. NI recognizes that eliminating certain hazardous substances from our products is beneficial to the environment and to NI customers.

For additional environmental information, refer to the *Minimize Our Environmental Impact* web page at [ni.com/environment](http://ni.com/environment). This page contains the environmental regulations and directives with which NI complies, as well as other environmental information not included in this document.

## Waste Electrical and Electronic Equipment (WEEE)



**EU Customers** At the end of the product life cycle, all products *must* be sent to a WEEE recycling center. For more information about WEEE recycling centers, National Instruments WEEE initiatives, and compliance with WEEE Directive 2002/96/EC on Waste and Electronic Equipment, visit [ni.com/environment/weee](http://ni.com/environment/weee).

## 电子信息产品污染控制管理办法（中国 RoHS）



**中国客户** National Instruments 符合中国电子信息产品中限制使用某些有害物质指令 (RoHS)。关于 National Instruments 中国 RoHS 合规性信息，请登录 [ni.com/environment/rohs\\_china](http://ni.com/environment/rohs_china)。(For information about China RoHS compliance, go to [ni.com/environment/rohs\\_china](http://ni.com/environment/rohs_china).)



# World Wide Support and Services

---

The National Instruments website is your complete resource for technical support. At [ni.com/support](https://ni.com/support) you have access to everything from troubleshooting and application development self-help resources to email and phone assistance from NI Application Engineers.

Visit [ni.com/services](https://ni.com/services) for NI Factory Installation Services, repairs, extended warranty, and other services.

Visit [ni.com/register](https://ni.com/register) to register your National Instruments product. Product registration facilitates technical support and ensures that you receive important information updates from NI.

National Instruments corporate headquarters is located at 11500 North Mopac Expressway, Austin, Texas, 78759-3504. National Instruments also has offices located around the world. For telephone support in the United States, create your service request at [ni.com/support](https://ni.com/support) or dial 1 866 ASK MYNI (275 6964). For telephone support outside the United States, visit the Worldwide Offices section of [ni.com/niglobal](https://ni.com/niglobal) to access the branch office websites, which provide up-to-date contact information, support phone numbers, email addresses, and current events.

Refer to the *NI Trademarks and Logo Guidelines* at [ni.com/trademarks](http://ni.com/trademarks) for more information on National Instruments trademarks. Other product and company names mentioned herein are trademarks or trade names of their respective companies. For patents covering National Instruments products/technology, refer to the appropriate location: **Help»Patents** in your software, the `patents.txt` file on your media, or the *National Instruments Patents Notice* at [ni.com/patents](http://ni.com/patents). You can find information about end-user license agreements (EULAs) and third-party legal notices in the readme file for your NI product. Refer to the *Export Compliance Information* at [ni.com/legal/export-compliance](http://ni.com/legal/export-compliance) for the National Instruments global trade compliance policy and how to obtain relevant HTS codes, ECCNs, and other import/export data. NI MAKES NO EXPRESS OR IMPLIED WARRANTIES AS TO THE ACCURACY OF THE INFORMATION CONTAINED HEREIN AND SHALL NOT BE LIABLE FOR ANY ERRORS. U.S. Government Customers: The data contained in this manual was developed at private expense and is subject to the applicable limited rights and restricted data rights as set forth in FAR 52.227-14, DFAR 252.227-7014, and DFAR 252.227-7015.

© 2016 National Instruments. All rights reserved.