

# XCL220B183FR-G Evaluation Board User Manual

## HiSAT-COT<sup>®</sup> Control 1.0A Inductor Built-in Step-Down “micro DC/DC” Converters

### **CAUTION**

#### **ENGINEERING EVALUATION PURPOSES ONLY**

This evaluation board is made for the purpose of the product evaluation.  
It is strictly prohibited to use this evaluation board for any other purpose.

Torex Semiconductor does not guarantee that all samples will perform in exactly the same way and we recommend that you always consult our product data sheets for the minimum and maximum specifications.

It is also important that you evaluate all our products carefully before mass

## **XCL220B183FR-G Evaluation Board**

*Inductor Built-in synchronous step-down micro DC/DC converte*

### **Evaluation Board Picture**



### **Evaluation Board SPEC**

						Ta=25°C
		CONDITON.	MIN.	TYP.	MAX.	UNIT
Vin	Input Voltage Range	-	2.5	-	5.5	V
Vout	Setting Output Voltage	-	-	1.8	-	V
Iout	Output Current	-	0	-	1000	mA
fosc	Switching frequency	-	-	3.0	-	MHz

### **XCL219/XCL220 Series Features**

- Input Voltage Range ..... 2.5V ~ 5.5V
- Output Voltage Range ..... 0.8V ~ 3.6V (step 0.05V)
- Max Output Current ..... 1000mA max.
- Switching frequency ..... 3MHz
- Max Duty Cycle ..... 100%
  
- Fast Load Transient Response
- Built-in Inductor
- Low EMI Noise

# XCL220B183FR-G Evaluation Board

Inductor Built-in synchronous step-down micro DC/DC converter

## Quick Start Procedure

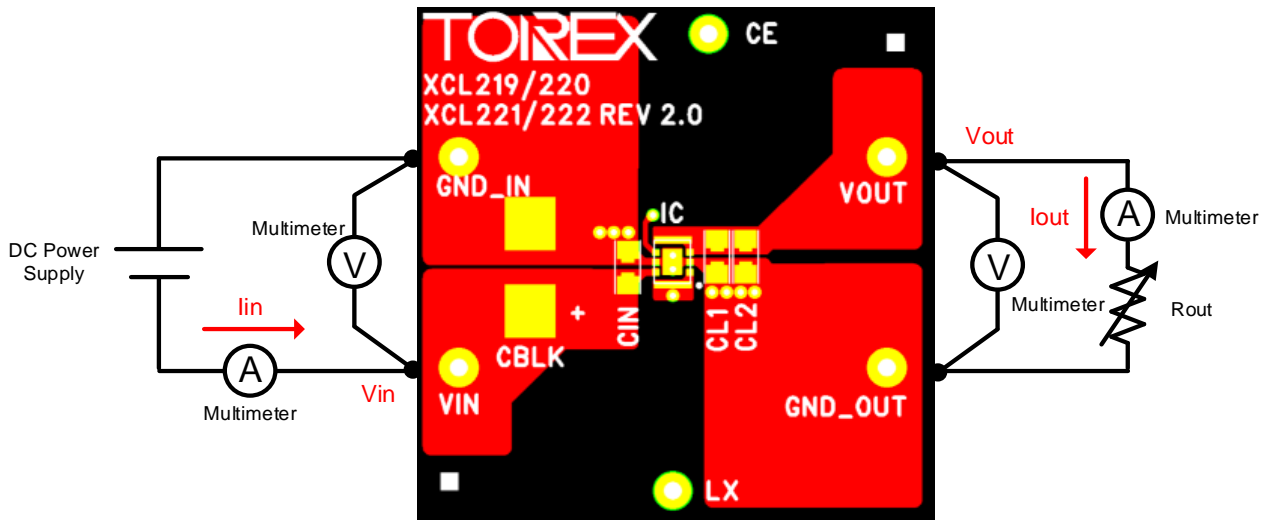

**XCL220B183FR-G Evaluation Board**

*Inductor Built-in synchronous step-down micro DC/DC converte*

**Schematic**

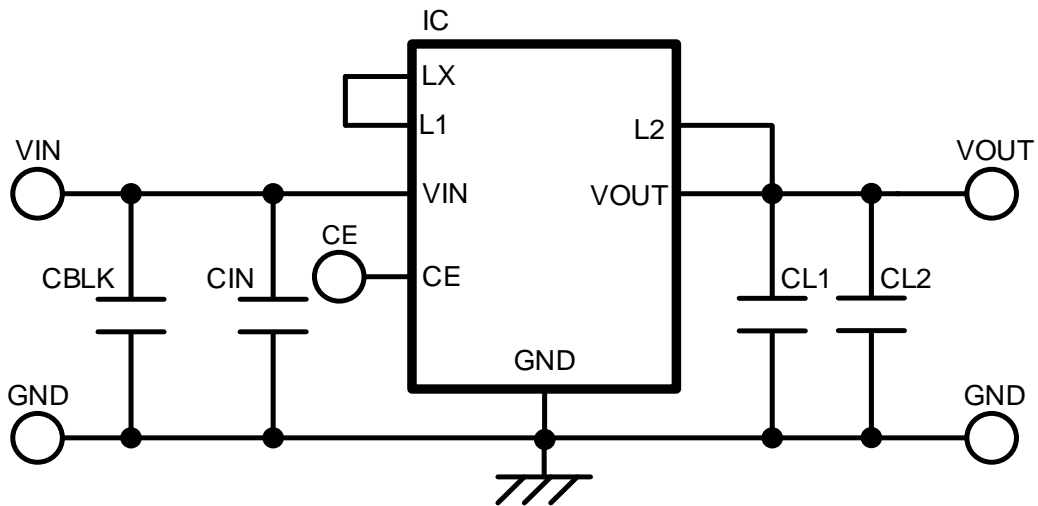

**BOM**

**Required Circuit Component**

Item	Value	Description	Size [mm]	Part Number	Manufacture
IC	-	Step-Down micro DC/DC Converters	CL-2025-02	XCL220B183FR-G	TOREX
CIN	10uF	Ceramic cap., 10V/10uF	1608	LMK107BBJ106MALT	Taiyo Yuden
CL1	10uF	Ceramic cap., 10V/10uF	1608	LMK107BBJ106MALT	Taiyo Yuden
CL2	10uF	Ceramic cap., 10V/10uF	1608	LMK107BBJ106MALT	Taiyo Yuden

**Additional Demo Board Circuit Components**

Item	Value	Description	Size [mm]	Part Number	Manufacture
CBLK	10uF	Ceramic cap., 50V/10uF	3225	CGA6P3X7S1H106K	TDK

# **XCL220B183FR-G Evaluation Board**

*Inductor Built-in synchronous step-down micro DC/DC converter*

## **PCB Layout**

**Layer 1**

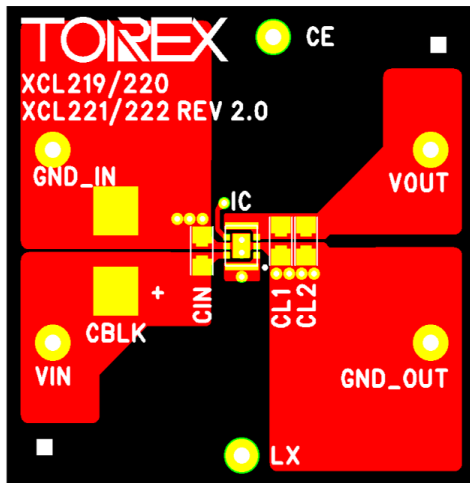

**Layer 2**

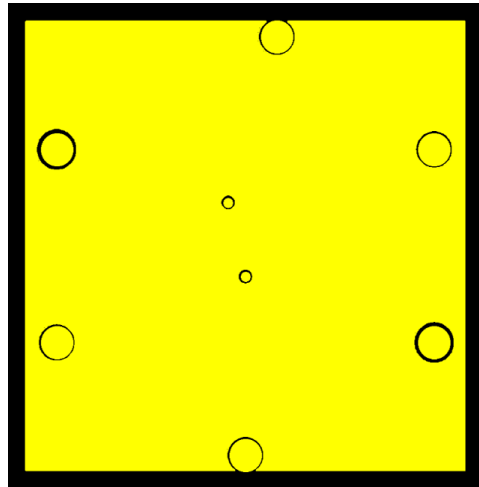

**Layer 3**

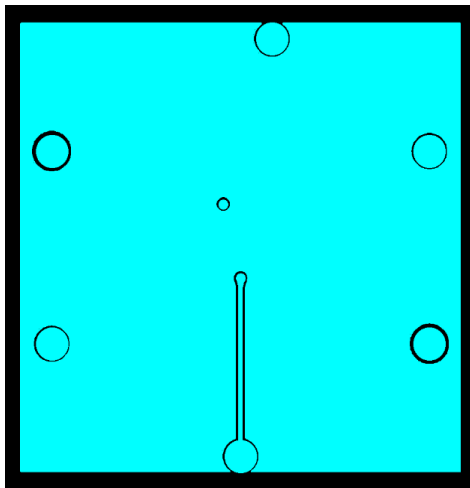

**Layer 4**

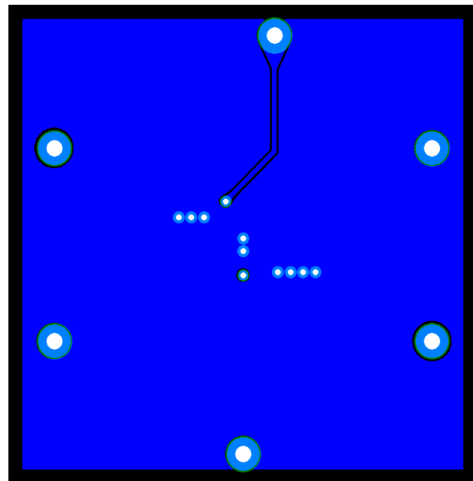

## **XCL220B183FR-G Evaluation Board**

*Inductor Built-in synchronous step-down micro DC/DC converter*

### **Test Result**

**(1) Output Voltage vs Output Current @Ta=25°C**

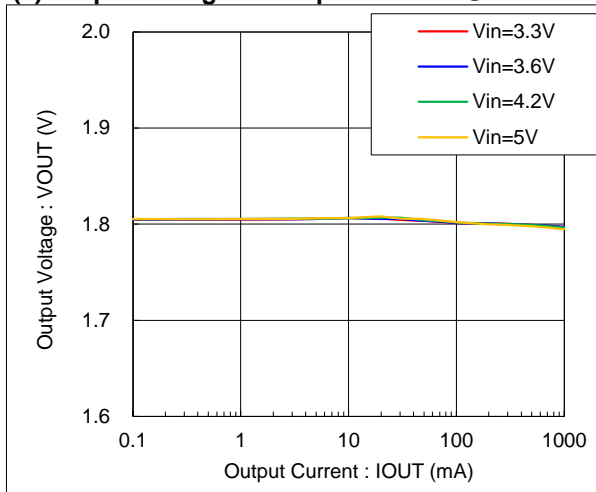

**(2) Efficiency vs Output Current Ta=25°C**

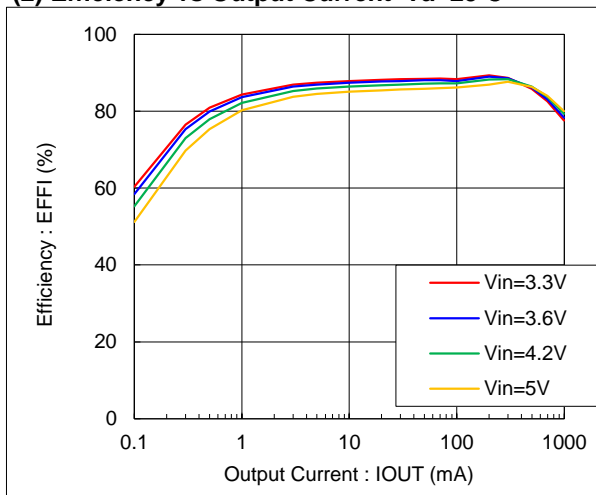

**(3) Ripple Voltage vs Output Current Ta=25°C**

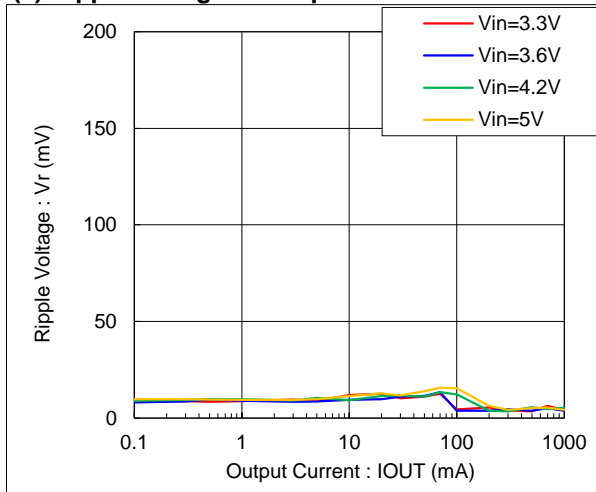

**XCL220B183FR-G Evaluation Board**

Inductor Built-in synchronous step-down micro DC/DC converter

**Test Result**

**(4) Output Voltage Waveform @ Ta=25°C**

**(4-1) Vin = 3.6V, Iout = 1mA**

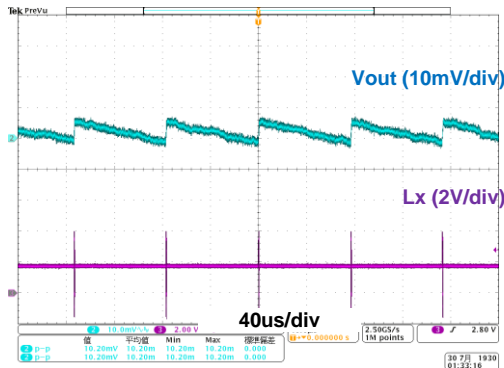

**(4-2) Vin = 3.6V, Iout = 300mA**

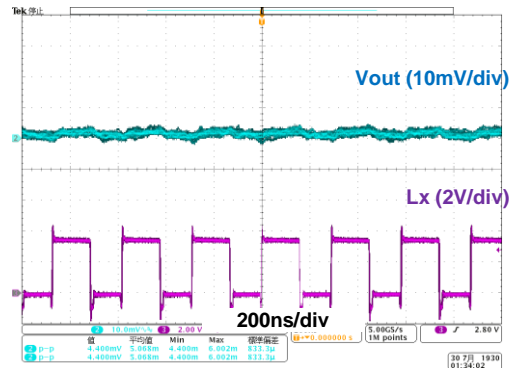

**(4-3) Vin = 5.0V, Iout = 1mA**

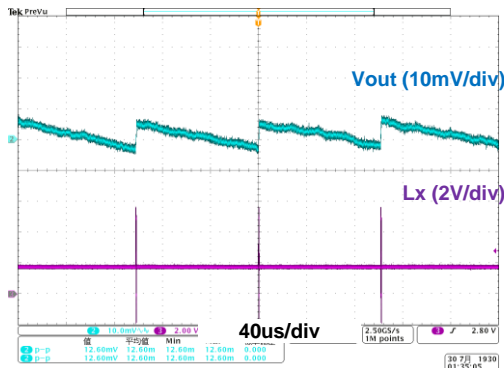

**(4-4) Vin = 5.0V, Iout = 300mA**

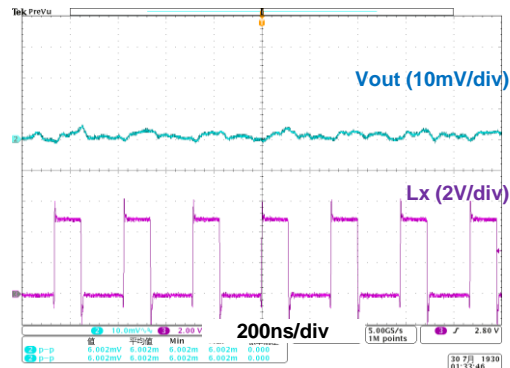

**XCL220B183FR-G Evaluation Board**

Inductor Built-in synchronous step-down micro DC/DC converter

**Test Result**

**(5) Start-up Waveform @ Ta=25°C**

**(5-1) Vin = 3.6V, Iout = 10mA**

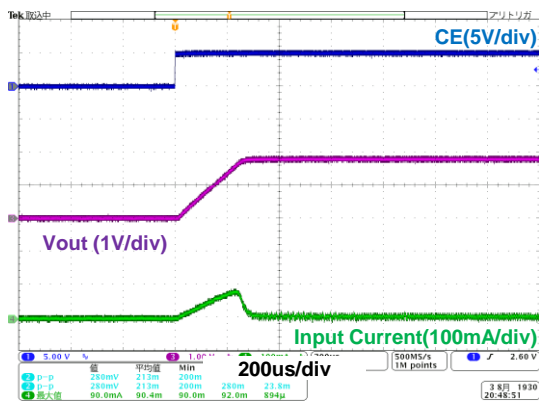

**(5-2) Vin = 3.6V, Iout = 300mA**

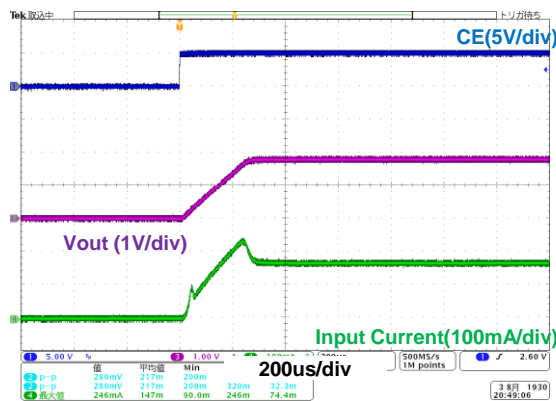

**(5-3) Vin = 5V, Iout = 10mA**

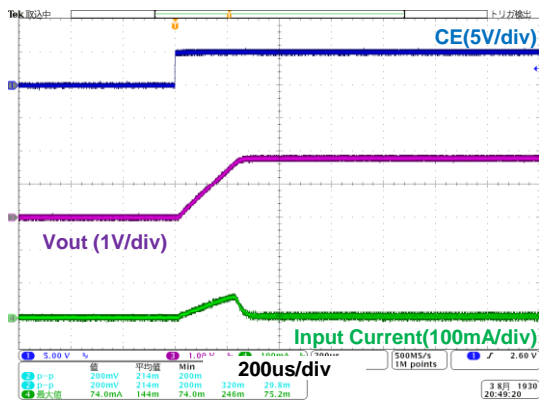

**(5-4) Vin = 5V, Iout = 300mA**

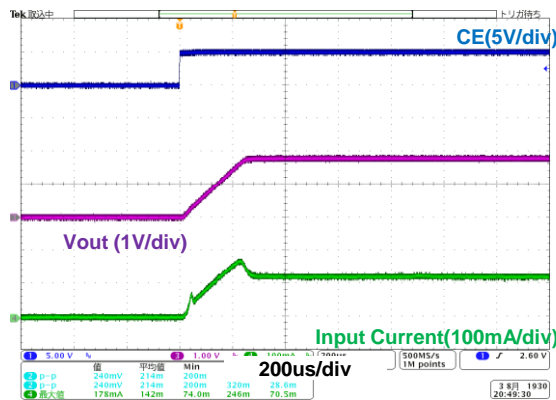



# XCL220B183FR-G Evaluation Board

Inductor Built-in synchronous step-down micro DC/DC converter

## Test Result

### (6) Load Transient Waveform @ Ta=25°C

(6-1) Vin = 3.6V, Iout = 1mA ↔ 300mA

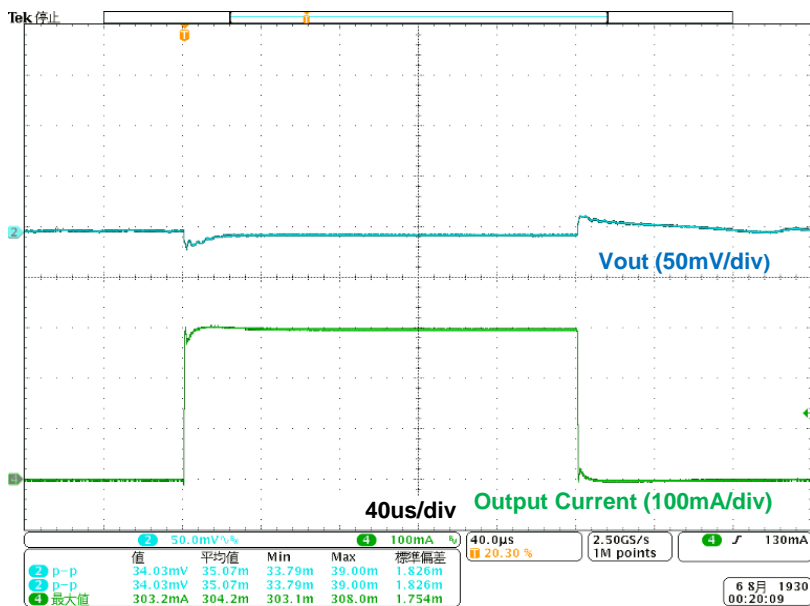

(6-2) Vin = 5V, Iout = 1mA ↔ 300mA

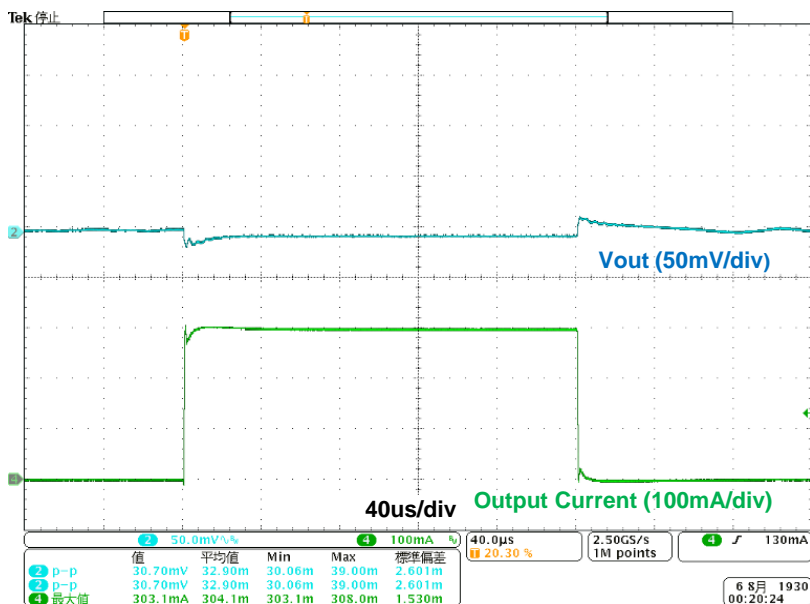

## XCL220B183FR-G Evaluation Board

Inductor Built-in synchronous step-down micro DC/DC converter

### 【Appendix】 How to calculate DC/DC Converter or DC/DC Controller.

It can be calculated by the following "WEB DC/DC Simulation".

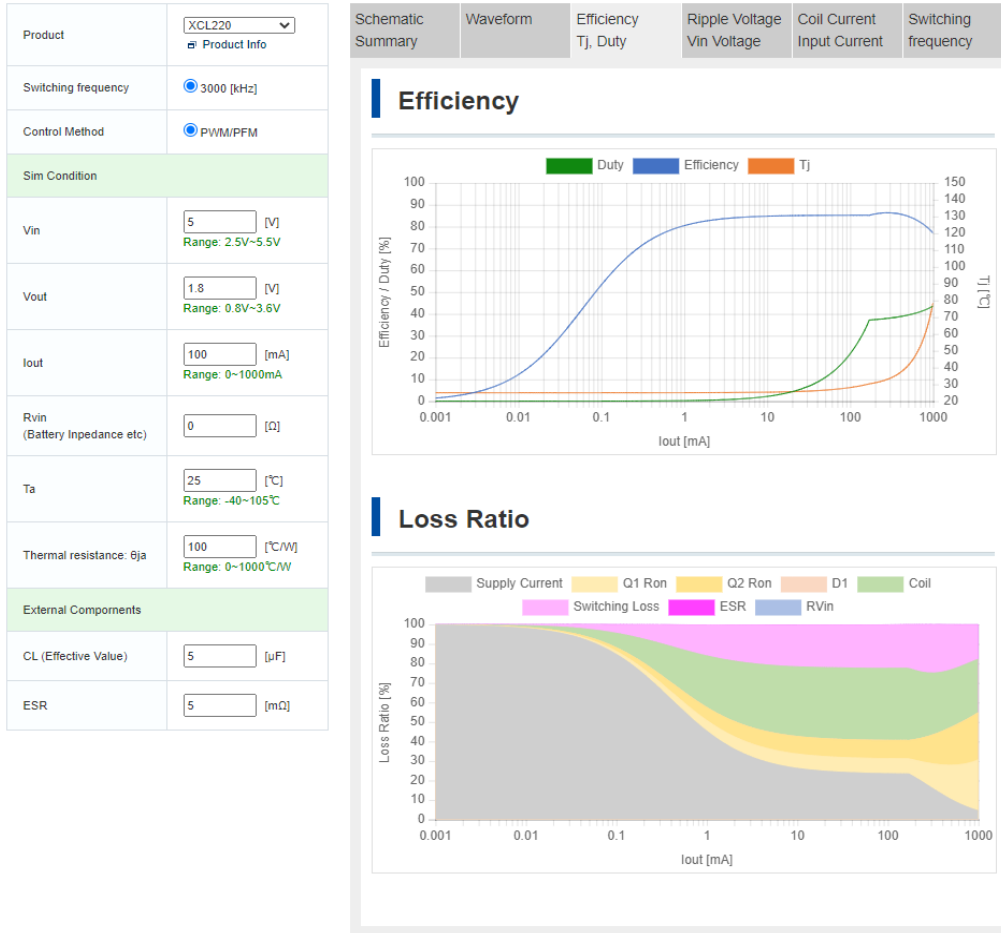

日本語 : <https://www.torex.co.jp/technical-support/dcdc-simulation/>  
 English : <https://www.torexsemi.com/technical-support/dcdc-simulation/>  
 简体中文 : <https://www.torex.com.cn/technical-support/dcdc-simulation/>

# XCL220B183FR-G Evaluation Board

Inductor Built-in synchronous step-down micro DC/DC converter

**[Appendix] How to reduce the spike noise caused by measurement (Probing method with oscilloscope)**

**Probing method : Before improvement**

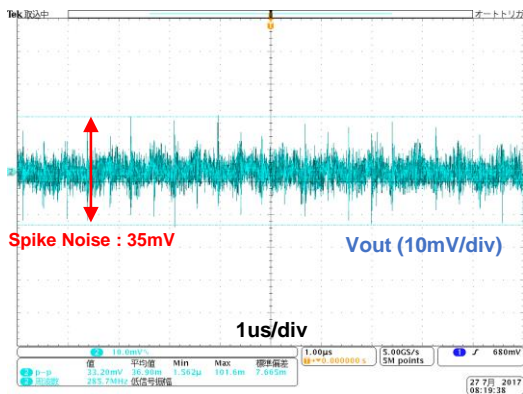
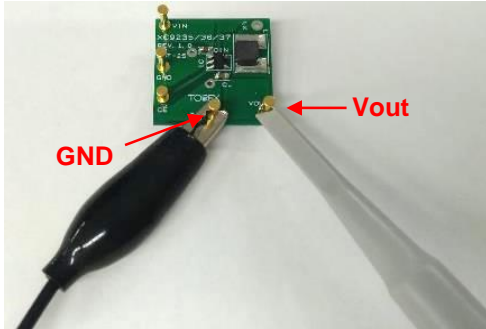

**Probing method : After**

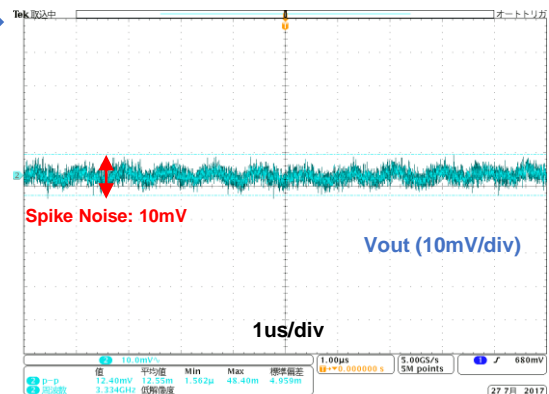
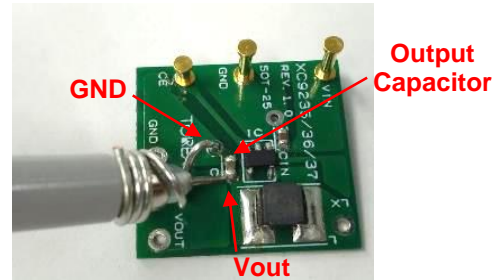

\* Condition : XC9236, Vin=3.6V/Vout=1.8V/100mA

English : <https://www.torexsemi.com/technical-support/tips/reduction-spike-noise/>

日本語 : <https://www.torex.co.jp/technical-support/tips/reduction-spike-noise/>