



Product Change Notification / SYST-29BWUI897

Date:

30-Jun-2021

Product Category:

Clock and Timing - Clock and Data Distribution

PCN Type:

Document Change

Notification Subject:

Data Sheet - SY89833L Data Sheet

Affected CPNs:

[SYST-29BWUI897_Affected_CPN_06302021.pdf](#)

[SYST-29BWUI897_Affected_CPN_06302021.csv](#)

Notification Text:

SYST-29BWUI897

Microchip has released a new Product Documents for the SY89833L Data Sheet of devices. If you are using one of these devices please read the document located at [SY89833L Data Sheet](#).

Notification Status: Final

Description of Change: 1) Converted Micrel document SY89833L to Microchip data sheet DS20005726A. 2) Minor text changes throughout. 3) Updated Figure 2-6.

Impacts to Data Sheet: None

Reason for Change: Conversion of Micrel datasheet to Microchip datasheet conventions.

Change Implementation Status: Complete

Date Document Changes Effective: 30 Jun 2021

NOTE: Please be advised that this is a change to the document only the product has not been changed.

Markings to Distinguish Revised from Unrevised Devices: N/A

Attachments:

[SY89833L Data Sheet](#)

Please contact your local [Microchip sales office](#) with questions or concerns regarding this notification.

Terms and Conditions:

If you wish to receive Microchip PCNs via email please register for our PCN email service at our [PCN home page](#) select register then fill in the required fields. You will find instructions about registering for Microchips PCN email service in the [PCN FAQ](#) section.

If you wish to change your PCN profile, including opt out, please go to the [PCN home page](#) select login and sign into your myMicrochip account. Select a profile option from the left navigation bar and make the applicable selections.

Affected Catalog Part Numbers (CPN)

SY89833LMG

SY89833LMG-TR

SY89833LMG-TX

SYST-29BWUI897 - Data Sheet - SY89833L Data Sheet

Affected Catalog Part Numbers(CPN)

SY89833LMG

SY89833LMG-TR

SY89833LMG-TX

3.3V Ultra-Precision 1:4 LVDS Fanout Buffer/Translator with Internal Termination

Features

- Guaranteed AC Performance Over Temperature and Voltage:
 - DC-to > 2 GHz throughput
 - <600 ps Propagation Delay (IN-to-Q)
 - <20 ps Within-Device Skew
 - <190 ps Rise/Fall Times
- Ultra-Low Jitter Design:
 - 96 fs_{RMS} Additive Phase Jitter (typical)
- Patented Any-In™ Input Termination and V_T Pin Accepts DC- and AC-Coupled Inputs
- High-Speed LVDS Outputs
- 3.3V Power Supply Operation
- Industrial Temperature Range: -40°C to +85°C
- Available in 16-Pin (3mm × 3mm) VQFN Package

Applications

- Processor Clock Distribution
- SONET Clock Distribution
- Fibre Channel Clock Distribution
- Gigabit Ethernet Clock Distribution

General Description

The SY89833L is a 3.3V, high-speed 2 GHz differential, low voltage differential swing (LVDS) 1:4 fanout buffer optimized for ultra-low skew applications. Within device skew is guaranteed to be less than 20 ps over supply voltage and temperature.

The differential input buffer has a unique internal termination design that allows access to the termination network through a V_T pin. This feature allows the device to easily interface to different logic standards. A V_{REF-AC} reference is included for AC-coupled applications.

The SY89833L is part of Microchip's high-speed clock synchronization family. For 2.5V applications, the SY89832U provides similar functionality while operating from a 2.5V ±5% supply. For applications that require a different I/O combination, consult the Microchip website and choose from a comprehensive product line of high-speed, low-skew fanout buffers, translators, and clock generators.

Package Type

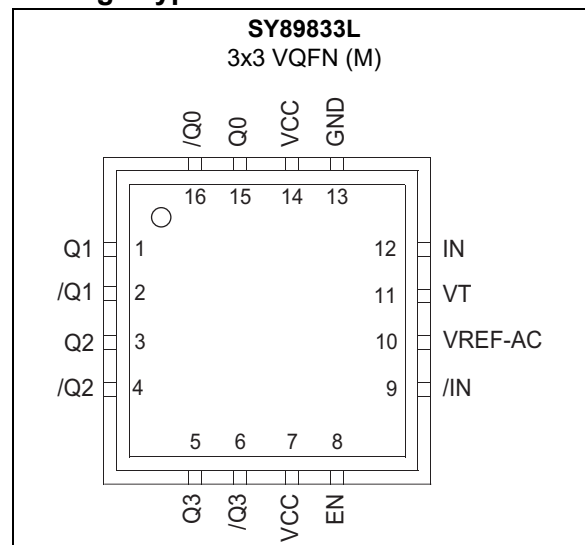

United States Patent No. RE44,134

SY89833L

Functional Block Diagram

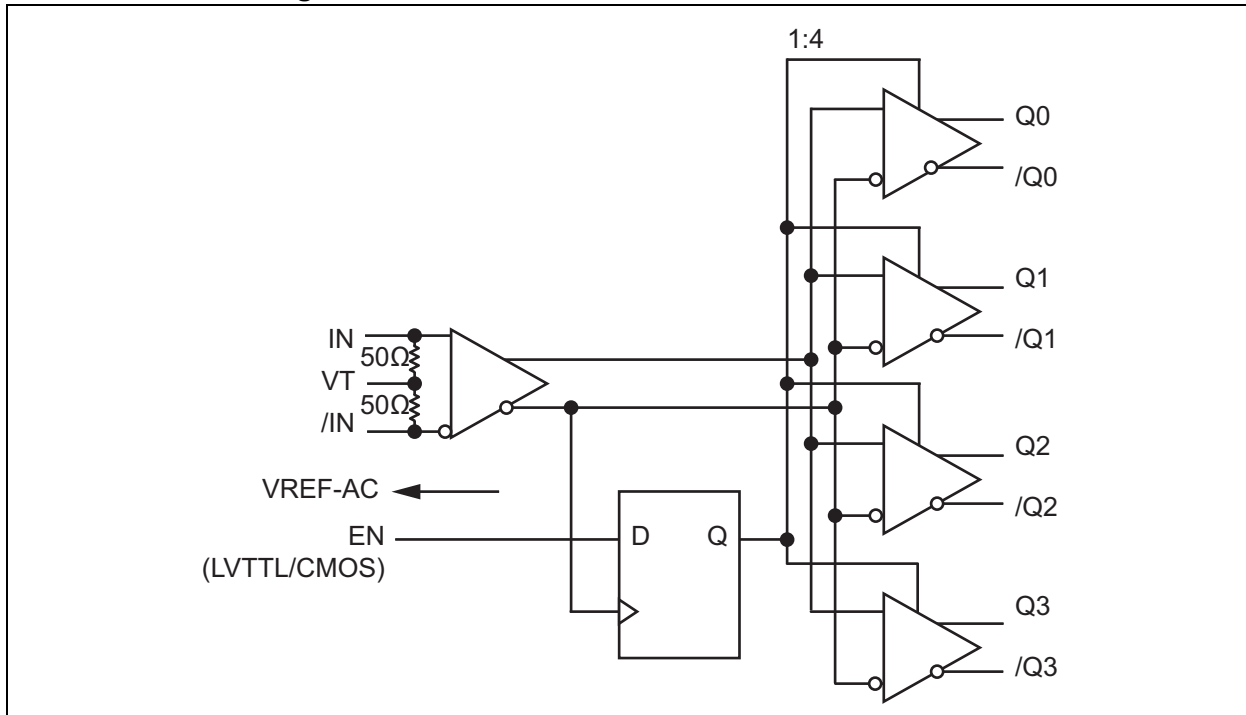

1.0 ELECTRICAL CHARACTERISTICS

Absolute Maximum Ratings †

Supply Voltage (V_{CC})	-0.5V to +4.0V
Input Voltage (V_{IN})	-0.5V to $V_{CC} + 0.3V$
LVDS Output Current (I_{OUT}).....	+10 mA
Input Current Source or Sink Current on (I_{VT})	± 2 mA

Operating Ratings ‡

Supply Voltage Range	+3.0V to +3.6V
----------------------------	----------------

† Notice: Stresses above those listed under “Absolute Maximum Ratings” may cause permanent damage to the device. This is a stress rating only and functional operation of the device at those or any other conditions above those indicated in the operational sections of this specification is not intended. Exposure to maximum rating conditions for extended periods may affect device reliability.

‡ Notice: The device is not guaranteed to function outside its operating ratings.

SY89833L

ELECTRICAL CHARACTERISTICS

Electrical Characteristics: $T_A = -40^\circ\text{C}$ to $+85^\circ\text{C}$, unless otherwise stated. (Note 1)						
Symbol	Parameters	Min.	Typ.	Max.	Units	Conditions
V_{CC}	Power Supply Voltage Range	3.0	3.3	3.6	V	—
I_{CC}	Power Supply Current	—	75	100	mA	—
R_{IN}	Input Resistance (IN-to- V_T)	45	50	55	Ω	—
$R_{DIFF-IN}$	Differential Input Resistance (IN-to-/IN)	90	100	110	Ω	—
V_{IH}	Input High Voltage (IN-to-/IN)	0.1	—	$V_{CC} + 0.3$	V	—
V_{IL}	Input Low Voltage (IN-to-/IN)	-0.3	—	$V_{IH} - 0.1$	V	—
V_{IN}	Input Voltage Swing (IN-to-/IN)	0.1	—	V_{CC}	V	Note 2, see Figure 5-3
V_{DIFF_IN}	Differential Input Voltage	0.2	—	—	V	Note 2, see Figure 5-4
$ I_{IN} $	Input Current (IN, /IN)	—	—	45	mA	Note 2
V_{REF-AC}	Reference Voltage	$V_{CC} - 1.525$	$V_{CC} - 1.425$	$V_{CC} - 1.325$	V	—

Note 1: The circuit is designed to meet the DC specifications shown in the above table after thermal equilibrium has been established.

2: Due to the internal termination, the input current depends on the applied voltages at IN, /IN, and V_T inputs. Do not apply a combination of voltages that causes the input current to exceed the maximum limit.

LVDS OUTPUTS DC ELECTRICAL CHARACTERISTICS

Electrical Characteristics: $V_{CC} = 3.3\text{V} \pm 10\%$, $R_L = 100\Omega$ across the outputs; $T_A = -40^\circ\text{C}$ to $+85^\circ\text{C}$. (Note 1)						
Symbol	Parameters	Min.	Typ.	Max.	Units	Conditions
V_{OUT}	Output Voltage Swing	250	325	—	mV	see Figure 5-3
V_{DIFF_OUT}	Differential Output Voltage Swing	500	650	—	mV	see Figure 5-4
V_{OCM}	Output Common-Mode Voltage	1.125	—	1.275	V	—
ΔV_{OCM}	Change in Common-Mode Voltage	-50	—	50	mV	—

Note 1: The circuit is designed to meet the DC specifications shown in the above table after thermal equilibrium has been established.

LVTTTL/CMOS DC ELECTRICAL CHARACTERISTICS

Electrical Characteristics: $V_{CC} = 3.3\text{V} \pm 10\%$, $T_A = -40^\circ\text{C}$ to $+85^\circ\text{C}$. (Note 1)						
Symbol	Parameters	Min.	Typ.	Max.	Units	Conditions
V_{IH}	Input High Voltage	2.0	—	V_{CC}	V	—
V_{IL}	Input Low Voltage	0	—	0.8	V	—
I_{IH}	Input High Current	-125	—	30	μA	—
I_{IL}	Input Low Current	-300	—	—	μA	—

Note 1: The circuit is designed to meet the DC specifications shown in the above table after thermal equilibrium has been established.

AC ELECTRICAL CHARACTERISTICS

Electrical Characteristics: $V_{CC} = 3.3V \pm 10\%$, $R_L = 100\Omega$ across the outputs; $T_A = -40^\circ C$ to $+85^\circ C$ unless otherwise stated. (Note 1)

Symbol	Parameters	Min.	Typ.	Max.	Units	Conditions
f_{MAX}	Maximum Frequency	2.0	—	—	GHz	$V_{OUT} \geq 200$ mV
t_{pd}	Propagation Delay (IN-to-Q)	400	500	600	ps	$V_{IN} < 400$ mV
		330	440	530	ps	$V_{IN} \geq 400$ mV
t_{SKEW}	Within-Device Skew	—	5	20	ps	Note 2
	Part-to-Part Skew	—	—	200	ps	Note 3
t_S	Set-Up Time (EN to IN, /IN)	300	—	—	ps	Note 4
t_H	Hold Time (IN, /IN to EN)	500	—	—	ps	Note 4
t_{JITTER}	Additive Phase Jitter, RMS	—	96	—	fs	622.08 MHz @ 3.3V, Integration Range: 12 kHz to 20 MHz
t_r/t_f	Output Rise/Fall Times (20% to 80%)	60	110	190	ps	At Full Output Swing

- Note 1:** High-frequency AC parameters are guaranteed by design and characterization.
- 2:** Within device skew is measured between two different outputs under identical input transitions.
- 3:** Part-to-part skew is defined for two parts with identical power supply voltages at the same temperature and no skew at the edges at the respective inputs.
- 4:** Set-up and hold times apply to synchronous applications that intend to enable/disable before the next clock cycle. For asynchronous applications, set-up and hold times do not apply.

SY89833L

TEMPERATURE SPECIFICATIONS

Parameters	Sym.	Min.	Typ.	Max.	Units	Conditions
Temperature Ranges						
Junction Operating Temperature	T_J	—	—	+125	°C	Note 1
Storage Temperature Range	T_S	-65	—	+150	°C	—
Lead Temperature	—	—	—	+260	°C	Soldering, 20s
Package Thermal Resistances (Note 2)						
16-pin 3 mm x 3 mm VQFN (Still-Air)	θ_{JA}	—	60	—	°C/W	—
16-pin 3 mm x 3 mm VQFN	Ψ_{JB}	—	33	—	°C/W	—

- Note 1:** The maximum allowable power dissipation is a function of ambient temperature, the maximum allowable junction temperature and the thermal resistance from junction to air (i.e., T_A , T_J , θ_{JA}). Exceeding the maximum allowable power dissipation will cause the device operating junction temperature to exceed the maximum +125°C rating. Sustained junction temperatures above +125°C can impact the device reliability.
- 2:** Package thermal resistance assumes exposed pad is soldered (or equivalent) to the device's most negative potential on the PCB. Ψ_{JB} and θ_{JA} values are determined for a 4-layer board in still-air number, unless otherwise stated.

2.0 TYPICAL PERFORMANCE CURVES

Note: The graphs and tables provided following this note are a statistical summary based on a limited number of samples and are provided for informational purposes only. The performance characteristics listed herein are not tested or guaranteed. In some graphs or tables, the data presented may be outside the specified operating range (e.g., outside specified power supply range) and therefore outside the warranted range.

$V_{CC} = 3.3V$, $GND = 0V$, $V_{IN} = 400\text{ mV}$, $R_L = 100\Omega$ across the outputs; $T_A = +25^\circ\text{C}$ unless otherwise stated.

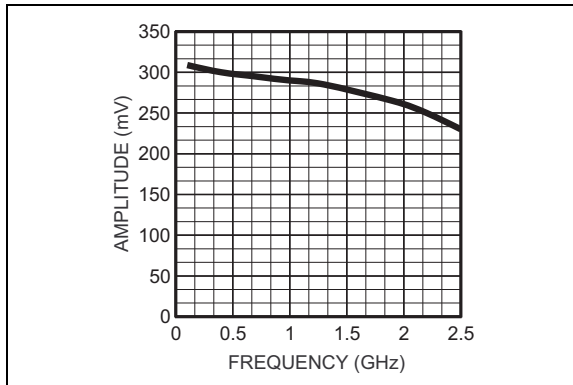

FIGURE 2-1: Output Swing vs. Frequency.

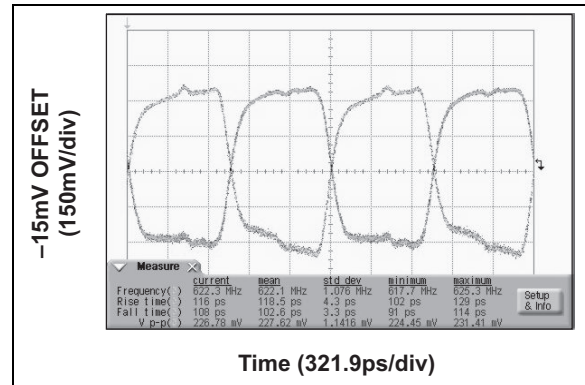

FIGURE 2-4: 622 MHz Output.

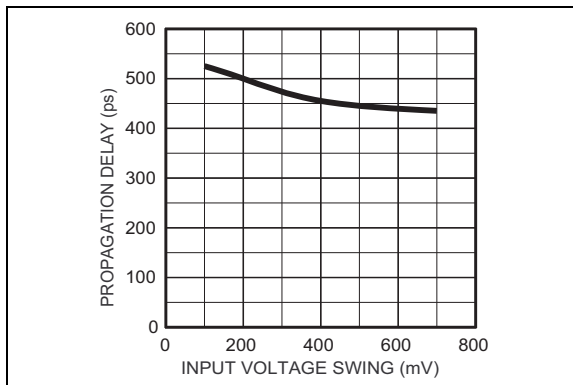

FIGURE 2-2: Propagation Delay vs. Input Voltage Swing.

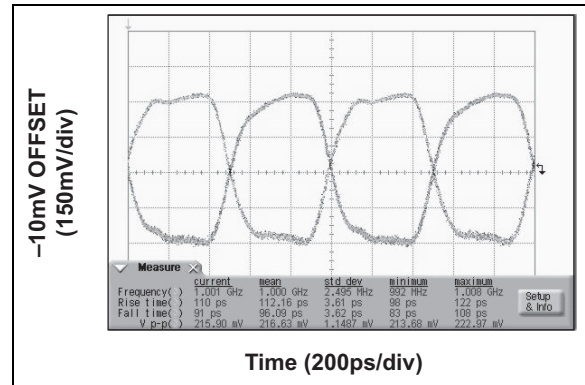

FIGURE 2-5: 1 GHz Output.

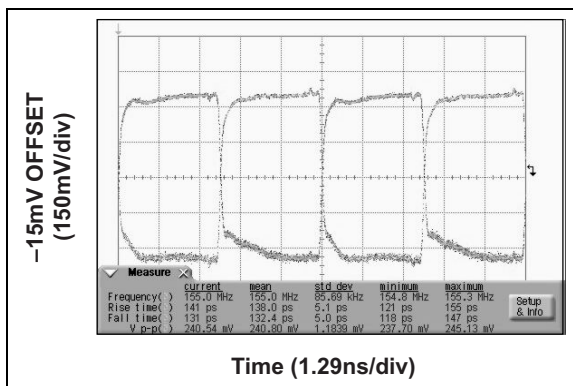

FIGURE 2-3: 155 MHz Output.

SY89833L

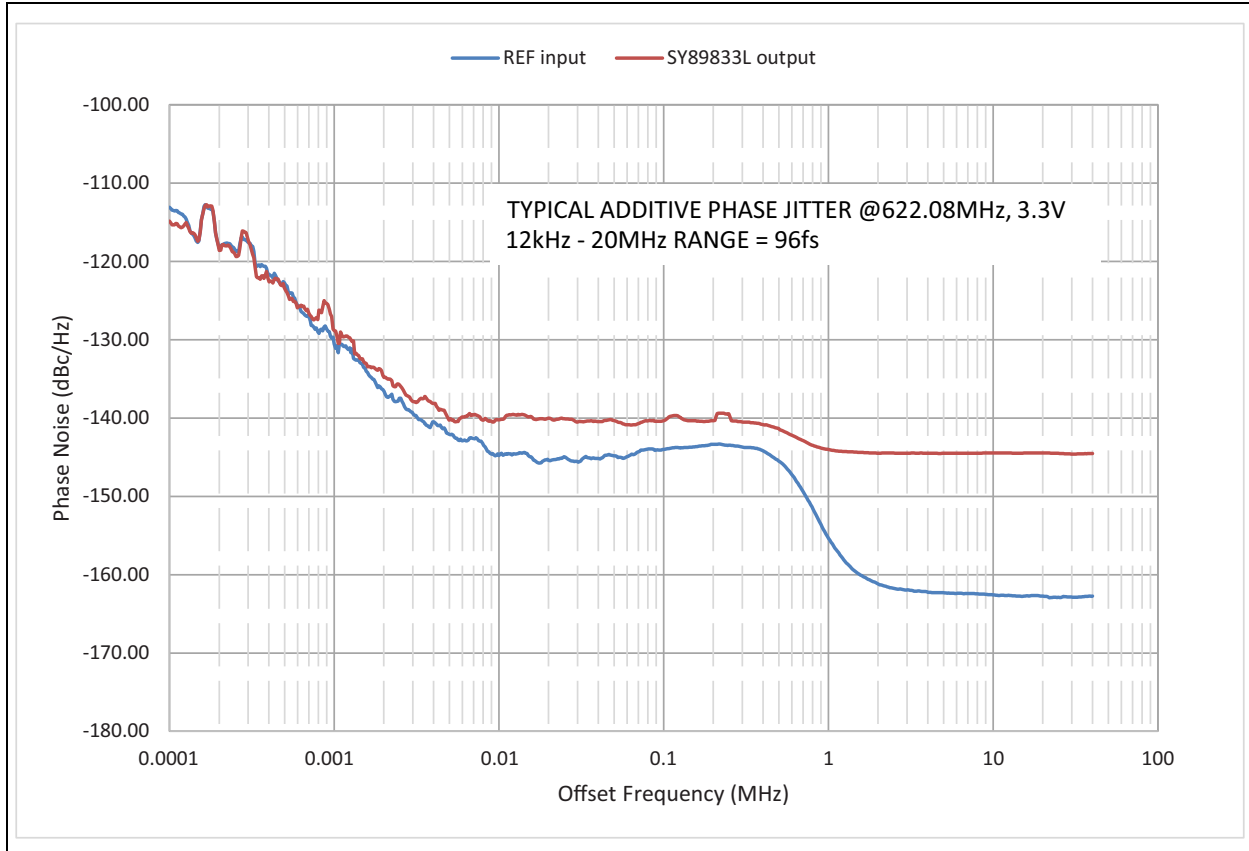

FIGURE 2-6: Additive Phase Noise Plot.

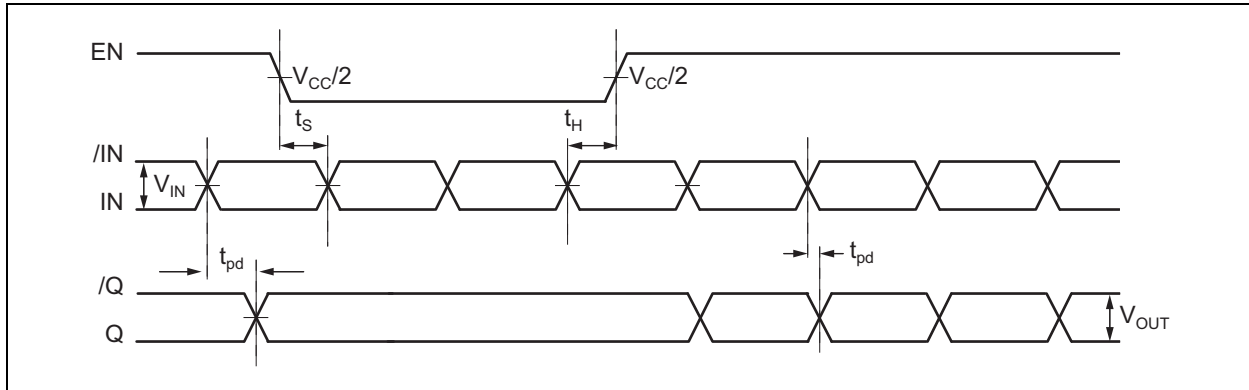

FIGURE 2-7: Timing Diagram.

3.0 PIN DESCRIPTIONS

The descriptions of the pins are listed in [Table 3-1](#).

TABLE 3-1: PIN FUNCTION TABLE

Pin Number	Pin Name	Description
15, 16 1, 2 3, 4 5, 6	Q0, /Q0 Q1, /Q1 Q2, /Q2 Q3, /Q3	LVDS Differential Outputs: Normally terminated with 100Ω across the pair (Q, /Q). See “LVDS Outputs” section. Unused outputs should be terminated with a 100Ω resistor across each pair.
8	EN	This single-ended TTL/CMOS-compatible input functions as a synchronous output enable. The synchronous enable ensures that enable/disable will only occur when the outputs are in a logic low state. Note that this input is internally connected to a 25 kΩ pull-up resistor and will default to logic high state (enabled) if left open.
9, 12	/IN, IN	Differential Inputs: These input pairs are the differential signal inputs to the device. Inputs accept AC- or DC-coupled differential signals as small as 100 mV. Each pin of a pair internally terminates to a V_T pin through 50Ω. Note that these inputs will default to an intermediate state if left open. Please refer to the Input Interface Applications section for more details.
10	V_{REF-AC}	Reference Voltage: These outputs bias to $V_{CC} - 1.425V$. They are used when AC coupling the inputs (IN, /IN). For AC-coupled applications, connect V_{REF-AC} to V_T pin and bypass with 0.01 μF low-ESR capacitor to V_{CC} . See the Input Interface Applications section for more details. Maximum sink/source current is ±1.5 mA.
11	V_T	Input Termination Center-Tap: Each side of the differential input pair terminates to a V_T pin. The V_T pin provides a center-tap to a termination network for maximum interface flexibility. See the Input Interface Applications section for more details.
13	GND	Ground. GND pin and exposed pad must be connected to the most negative potential of the device ground.
7, 14	V_{CC}	Positive Power Supply: Bypass with 0.1 μF//0.01 μF low-ESR capacitors and place as close as possible to each V_{CC} pin.

TABLE 3-2: TRUTH TABLE

IN	/IN	EN	Q	/Q
0	1	1	0	1
1	0	1	1	0
X	X	0	0 (Note 1)	1 (Note 1)

Note 1: On next negative transition of the input signal (IN).

SY89833L

4.0 INPUT INFORMATION

4.1 Input Stage

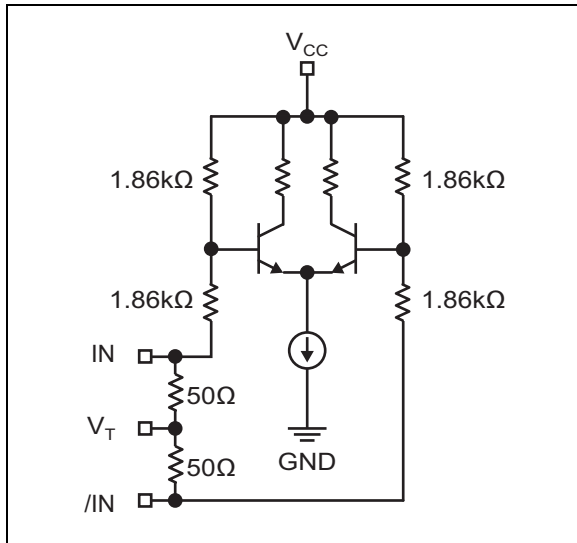

FIGURE 4-1: Simplified Differential Input Buffer.

4.2 Input Interface Applications

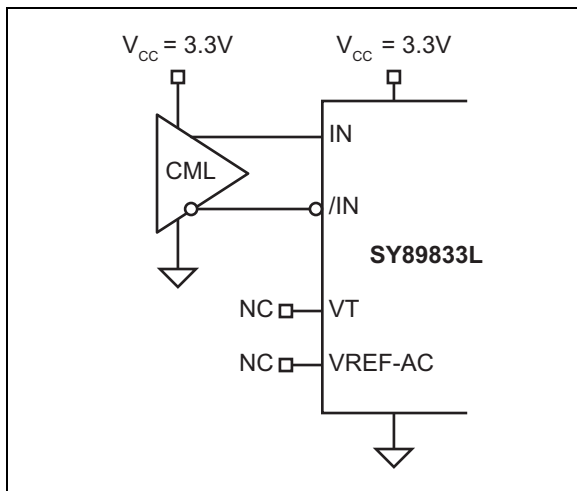

FIGURE 4-2: DC-Coupled CML Input Interface.

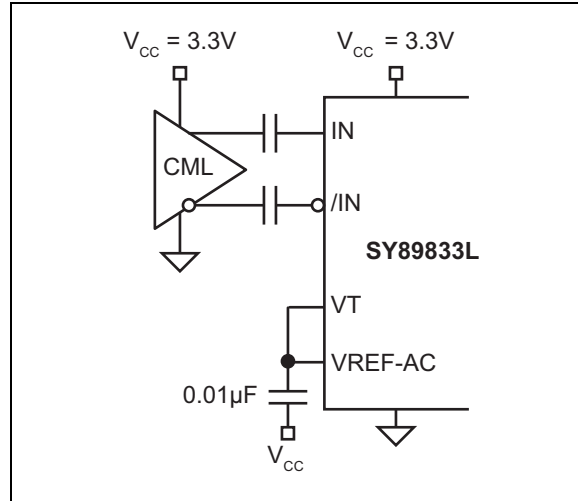

FIGURE 4-3: AC-Coupled CML Input Interface.

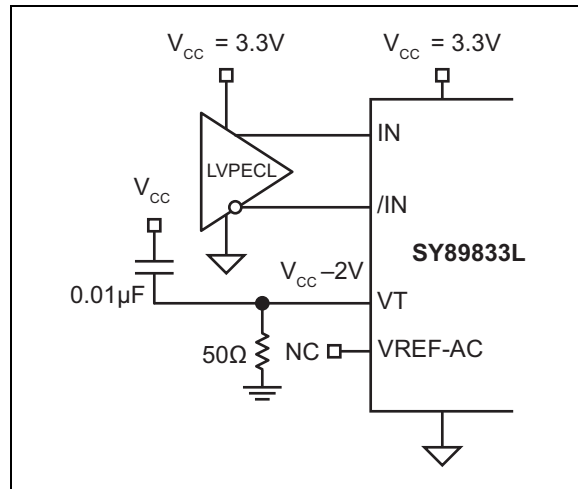

FIGURE 4-4: DC-Coupled LVPECL Input Interface.

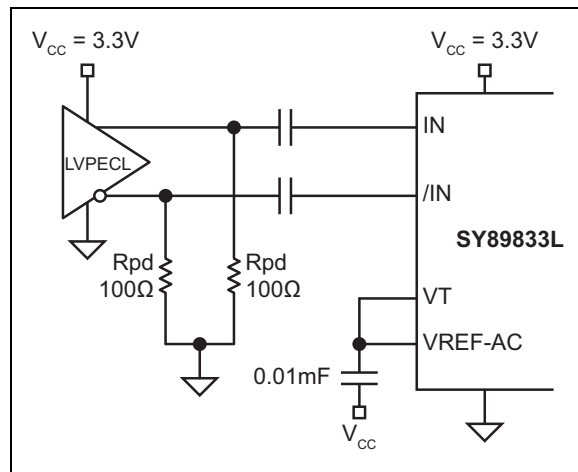

FIGURE 4-5: AC-Coupled LVPECL Input Interface.

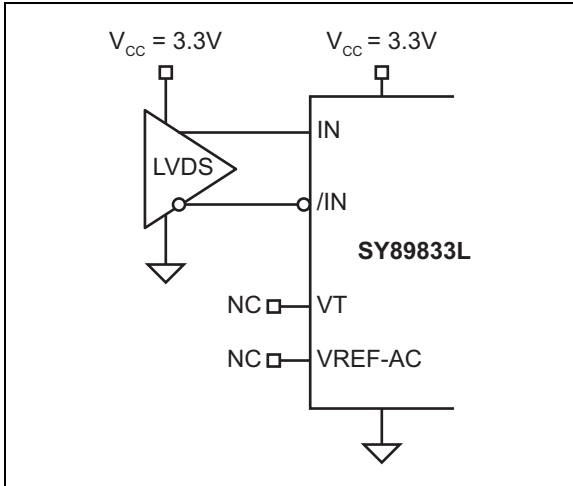

FIGURE 4-6: LVDS Input Interface.

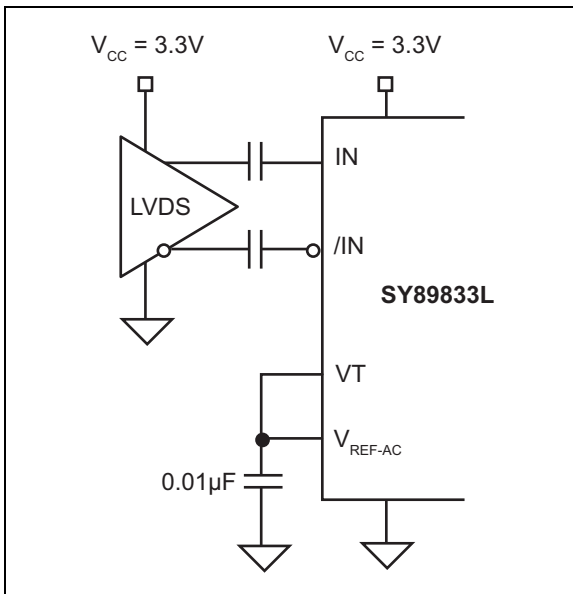

FIGURE 4-7: AC-Coupled LVDS Input Interface.

Please note: be certain that the LVDS driver can be AC-coupled before attempting this design.

SY89833L

5.0 LVDS OUTPUTS

LVDS specifies a small swing of 325 mV typical, on a nominal 1.20V common-mode above ground. The common-mode voltage has tight limits to permit large variations in ground noise between a LVDS driver and receiver.

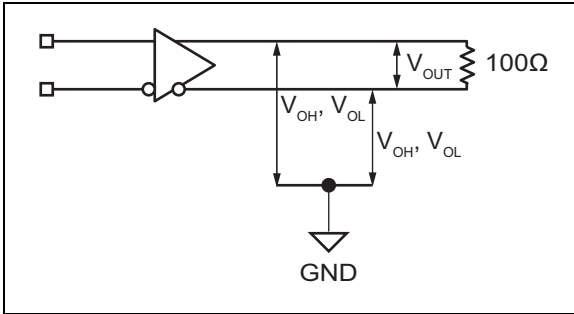

FIGURE 5-1: LVDS Differential Measurement.

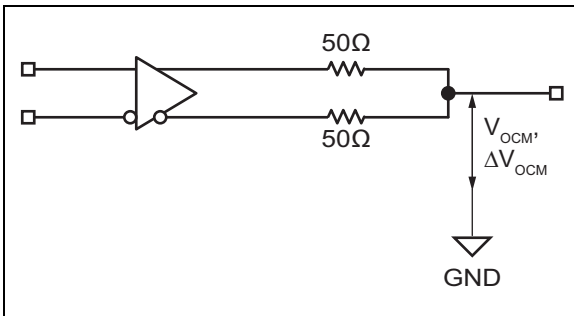

FIGURE 5-2: LVDS Common-Mode Measurement.

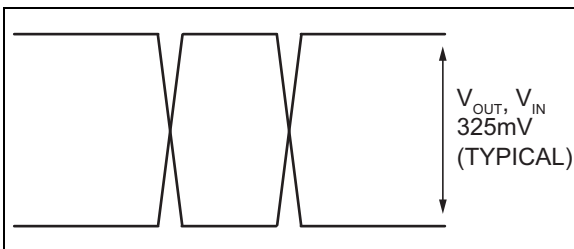

FIGURE 5-3: Single-Ended Swing.

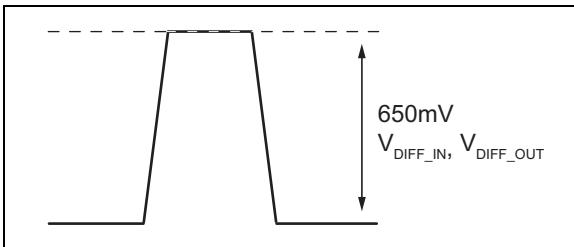
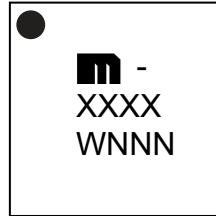

FIGURE 5-4: Differential Swing.

6.0 PACKAGING INFORMATION

6.1 Package Marking Information

16-Lead VQFN*



Example

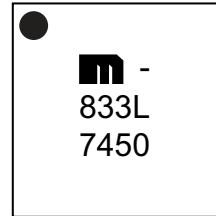

Legend:	XX...X	Product code or customer-specific information
	Y	Year code (last digit of calendar year)
	YY	Year code (last 2 digits of calendar year)
	WW	Week code (week of January 1 is week '01')
	NNN	Alphanumeric traceability code
	(e3)	Pb-free JEDEC® designator for Matte Tin (Sn)
	*	This package is Pb-free. The Pb-free JEDEC designator (e3) can be found on the outer packaging for this package.
	•, ▲, ▼	Pin one index is identified by a dot, delta up, or delta down (triangle mark).
Note:	In the event the full Microchip part number cannot be marked on one line, it will be carried over to the next line, thus limiting the number of available characters for customer-specific information. Package may or may not include the corporate logo.	
	Underbar (_) and/or Overbar (¯) symbol may not be to scale.	

SY89833L

16-Lead 3 mm x 3 mm VQFN Package Outline and Recommended Land Pattern

16-Lead Ultra Thin Plastic Quad Flat, No Lead Package (NCA) - 3x3x1.0 mm Body [VQFN]

Note: For the most current package drawings, please see the Microchip Packaging Specification located at <http://www.microchip.com/packaging>

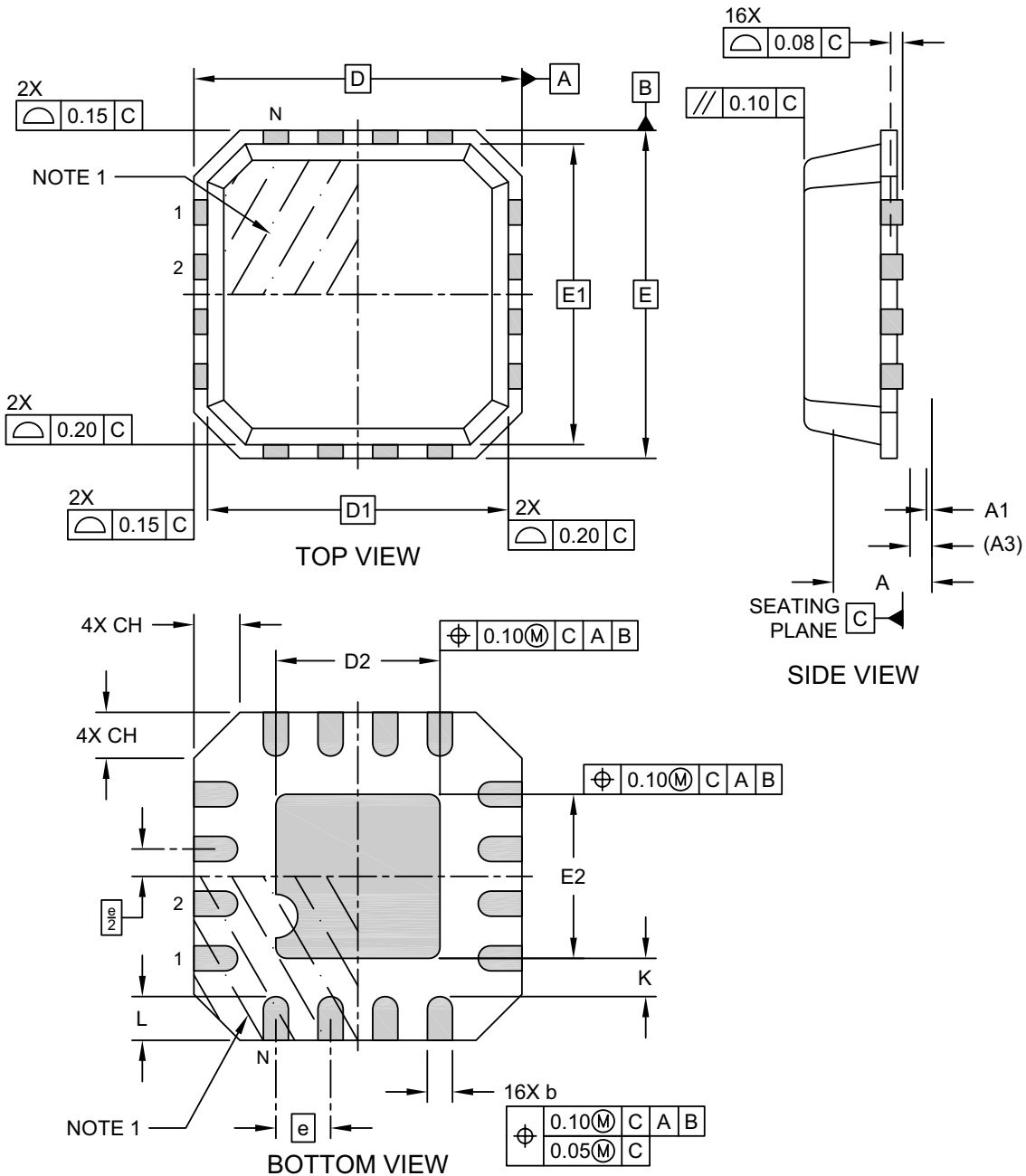

Microchip Technology Drawing C04-1103-NCA Rev A Sheet 1 of 2

16-Lead Ultra Thin Plastic Quad Flat, No Lead Package (NCA) - 3x3x1.0 mm Body [VQFN]

Note: For the most current package drawings, please see the Microchip Packaging Specification located at <http://www.microchip.com/packaging>

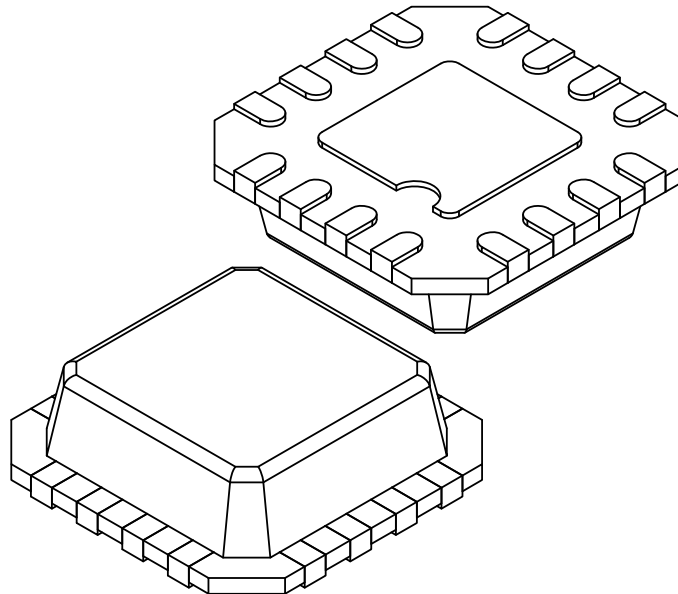

Dimension Limits	Units	MILLIMETERS		
		MIN	NOM	MAX
Number of Terminals	N	16		
Pitch	e	0.50 BSC		
Overall Height	A	0.85	-	1.00
Standoff	A1	0.00	0.02	0.05
Terminal Thickness	A3	0.20 REF		
Overall Length	D	3.00 BSC		
Mold Cap Length	D1	2.75 BSC		
Exposed Pad Length	D2	1.35	1.50	1.65
Overall Width	E	3.00 BSC		
Mold Cap Width	E1	2.75 BSC		
Exposed Pad Width	E2	1.35	1.50	1.65
Body Corner Chamfer	CH	0.24	0.42	0.60
Terminal Width	b	0.16	0.23	0.28
Terminal Length	L	0.10	0.40	0.50
Terminal-to-Exposed-Pad	K	0.20	-	-

Notes:

- Pin 1 visual index feature may vary, but must be located within the hatched area.
- Package is punch singulated
- Dimensioning and tolerancing per ASME Y14.5M
 BSC: Basic Dimension. Theoretically exact value shown without tolerances.
 REF: Reference Dimension, usually without tolerance, for information purposes only.

Microchip Technology Drawing C04-1103-NCA Rev A Sheet 1 of 2

SY89833L

16-Lead Ultra Thin Plastic Quad Flat, No Lead Package (NCA) - 3x3x1.0 mm Body [VQFN]

Note: For the most current package drawings, please see the Microchip Packaging Specification located at <http://www.microchip.com/packaging>

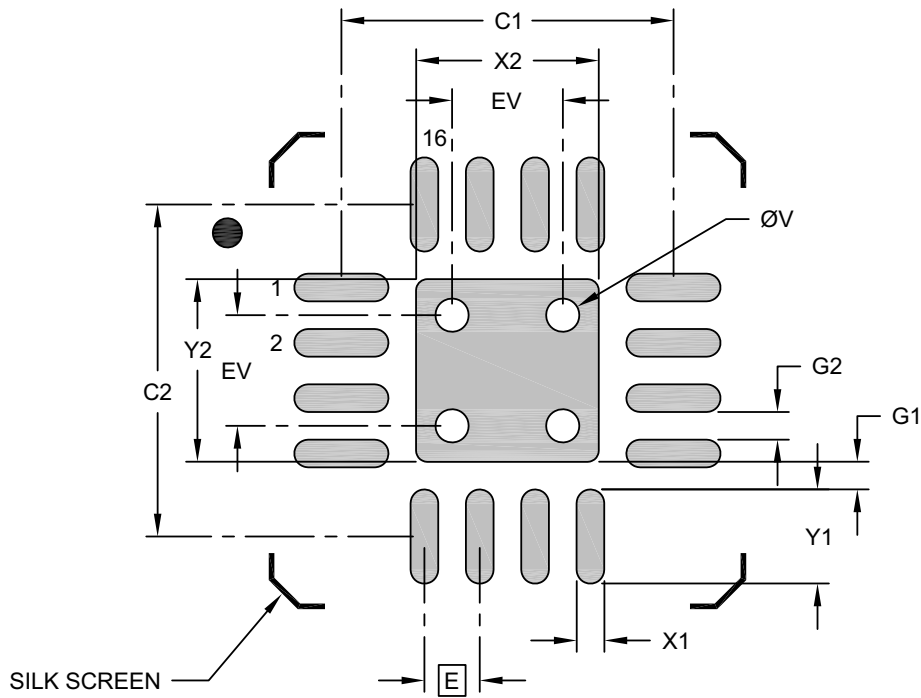

RECOMMENDED LAND PATTERN

Dimension Limits	Units	MILLIMETERS		
		MIN	NOM	MAX
Contact Pitch	E	0.50 BSC		
Optional Center Pad Width	X2			1.65
Optional Center Pad Length	Y2			1.65
Contact Pad Spacing	C1		3.00	
Contact Pad Spacing	C2		3.00	
Contact Pad Width (x16)	X1			0.25
Contact Pad Length (x16)	Y1			0.85
Contact Pad to Center Pad (x16)	G1	0.25		
Contact Pad to Contact Pad (X12)	G2	0.25		
Thermal Via Diameter	V		0.30	
Thermal Via Pitch	EV		1.00	

Notes:

1. Dimensioning and tolerancing per ASME Y14.5M
BSC: Basic Dimension. Theoretically exact value shown without tolerances.
2. For best soldering results, thermal vias, if used, should be filled or tented to avoid solder loss during reflow process

Microchip Technology Drawing C04-1103-NCA Rev A

APPENDIX A: REVISION HISTORY

Revision A (June 2021)

- Converted Micrel document SY89833L to Microchip data sheet DS20005726A.
- Minor text changes throughout.
- Updated [Figure 2-6](#).

SY89833L

NOTES:

PRODUCT IDENTIFICATION SYSTEM

To order or obtain information, e.g., on pricing or delivery, contact your local Microchip representative or sales office.

<u>PART NO.</u>	X	X	X	XX
Device	Voltage Option	Package	Temperature	Special Processing
Device: SY89833:	3.3V Ultra-Precision 1:4 LVDS Fanout Buffer/Translator with Internal Termination			
Voltage Option: L =	3.3V Only			
Package: M =	16-Lead 3 mm x 3 mm VQFN			
Temperature: G =	-40°C to +85°C			
Special Processing:	<blank> = 100/Tube TR = 1,000/Reel			
Note 1: Contact factory for die availability. Dice are guaranteed at $T_A = 25^\circ\text{C}$, DC Electricals only.				

Examples:

- a) SY89833LMG: 3.3V Ultra-Precision 1:4 LVDS Fanout Buffer/Translator with Internal Termination, 3.3V Voltage Option, -40°C to +85°C Temp. Range, 16-Lead VQFN 100/Tube
- b) SY89833LMG TR: 3.3V Ultra-Precision 1:4 LVDS Fanout Buffer/Translator with Internal Termination, 3.3V Voltage Option, -40°C to +85°C Temp. Range, 16-Lead VQFN, 1,000/Reel

Note 1: Tape and Reel identifier only appears in the catalog part number description. This identifier is used for ordering purposes and is not printed on the device package. Check with your Microchip Sales Office for package availability with the Tape and Reel option.

SY89833L

NOTES:

Note the following details of the code protection feature on Microchip devices:

- Microchip products meet the specifications contained in their particular Microchip Data Sheet.
- Microchip believes that its family of products is secure when used in the intended manner and under normal conditions.
- There are dishonest and possibly illegal methods being used in attempts to breach the code protection features of the Microchip devices. We believe that these methods require using the Microchip products in a manner outside the operating specifications contained in Microchip's Data Sheets. Attempts to breach these code protection features, most likely, cannot be accomplished without violating Microchip's intellectual property rights.
- Microchip is willing to work with any customer who is concerned about the integrity of its code.
- Neither Microchip nor any other semiconductor manufacturer can guarantee the security of its code. Code protection does not mean that we are guaranteeing the product is "unbreakable." Code protection is constantly evolving. We at Microchip are committed to continuously improving the code protection features of our products. Attempts to break Microchip's code protection feature may be a violation of the Digital Millennium Copyright Act. If such acts allow unauthorized access to your software or other copyrighted work, you may have a right to sue for relief under that Act.

Information contained in this publication is provided for the sole purpose of designing with and using Microchip products. Information regarding device applications and the like is provided only for your convenience and may be superseded by updates. It is your responsibility to ensure that your application meets with your specifications.

THIS INFORMATION IS PROVIDED BY MICROCHIP "AS IS". MICROCHIP MAKES NO REPRESENTATIONS OR WARRANTIES OF ANY KIND WHETHER EXPRESS OR IMPLIED, WRITTEN OR ORAL, STATUTORY OR OTHERWISE, RELATED TO THE INFORMATION INCLUDING BUT NOT LIMITED TO ANY IMPLIED WARRANTIES OF NON-INFRINGEMENT, MERCHANTABILITY, AND FITNESS FOR A PARTICULAR PURPOSE OR WARRANTIES RELATED TO ITS CONDITION, QUALITY, OR PERFORMANCE.

IN NO EVENT WILL MICROCHIP BE LIABLE FOR ANY INDIRECT, SPECIAL, PUNITIVE, INCIDENTAL OR CONSEQUENTIAL LOSS, DAMAGE, COST OR EXPENSE OF ANY KIND WHATSOEVER RELATED TO THE INFORMATION OR ITS USE, HOWEVER CAUSED, EVEN IF MICROCHIP HAS BEEN ADVISED OF THE POSSIBILITY OR THE DAMAGES ARE FORESEEABLE. TO THE FULLEST EXTENT ALLOWED BY LAW, MICROCHIP'S TOTAL LIABILITY ON ALL CLAIMS IN ANY WAY RELATED TO THE INFORMATION OR ITS USE WILL NOT EXCEED THE AMOUNT OF FEES, IF ANY, THAT YOU HAVE PAID DIRECTLY TO MICROCHIP FOR THE INFORMATION. Use of Microchip devices in life support and/or safety applications is entirely at the buyer's risk, and the buyer agrees to defend, indemnify and hold harmless Microchip from any and all damages, claims, suits, or expenses resulting from such use. No licenses are conveyed, implicitly or otherwise, under any Microchip intellectual property rights unless otherwise stated.

Trademarks

The Microchip name and logo, the Microchip logo, Adaptec, AnyRate, AVR, AVR logo, AVR Freaks, BesTime, BitCloud, chipKIT, chipKIT logo, CryptoMemory, CryptoRF, dsPIC, FlashFlex, flexPWR, HELDO, IGL00, JukeBlox, KeeLoq, Kleer, LANCheck, LinkMD, maXStylus, maXTouch, MediaLB, megaAVR, Microsemi, Microsemi logo, MOST, MOST logo, MPLAB, OptoLyzer, PackeTime, PIC, picoPower, PICSTART, PIC32 logo, PolarFire, Prochip Designer, QTouch, SAM-BA, SenGenuity, SpyNIC, SST, SST Logo, SuperFlash, Symmetricom, SyncServer, Tachyon, TimeSource, tinyAVR, UNI/O, Vectron, and XMEGA are registered trademarks of Microchip Technology Incorporated in the U.S.A. and other countries.

AgileSwitch, APT, ClockWorks, The Embedded Control Solutions Company, EtherSynch, FlashTec, Hyper Speed Control, HyperLight Load, IntelliMOS, Libero, motorBench, mTouch, Powermite 3, Precision Edge, ProASIC, ProASIC Plus, ProASIC Plus logo, Quiet-Wire, SmartFusion, SyncWorld, Temux, TimeCesium, TimeHub, TimePictra, TimeProvider, WinPath, and ZL are registered trademarks of Microchip Technology Incorporated in the U.S.A.

Adjacent Key Suppression, AKS, Analog-for-the-Digital Age, Any Capacitor, AnyIn, AnyOut, Augmented Switching, BlueSky, BodyCom, CodeGuard, CryptoAuthentication, CryptoAutomotive, CryptoCompanion, CryptoController, dsPICDEM, dsPICDEM.net, Dynamic Average Matching, DAM, ECAN, Espresso T1S, EtherGREEN, IdealBridge, In-Circuit Serial Programming, ICSP, INICnet, Intelligent Paralleling, Inter-Chip Connectivity, JitterBlocker, maxCrypto, maxView, memBrain, Mindi, MiWi, MPASM, MPF, MPLAB Certified logo, MPLIB, MPLINK, MultiTRAK, NetDetach, Omniscient Code Generation, PICDEM, PICDEM.net, PICkit, PICtail, PowerSmart, PureSilicon, QMatrix, REAL ICE, Ripple Blocker, RTAX, RTG4, SAM-ICE, Serial Quad I/O, simpleMAP, SimpliPHY, SmartBuffer, SMART-I.S., storClad, SQI, SuperSwitcher, SuperSwitcher II, Switchtec, SynchroPHY, Total Endurance, TSHARC, USBCheck, VariSense, VectorBlox, VeriPHY, ViewSpan, WiperLock, XpressConnect, and ZENA are trademarks of Microchip Technology Incorporated in the U.S.A. and other countries.

SQTP is a service mark of Microchip Technology Incorporated in the U.S.A.

The Adaptec logo, Frequency on Demand, Silicon Storage Technology, and Symmcom are registered trademarks of Microchip Technology Inc. in other countries.

GestIC is a registered trademark of Microchip Technology Germany II GmbH & Co. KG, a subsidiary of Microchip Technology Inc., in other countries.

All other trademarks mentioned herein are property of their respective companies.

© 2021, Microchip Technology Incorporated, All Rights Reserved.

ISBN: 978-1-5224-8483-7

For information regarding Microchip's Quality Management Systems, please visit www.microchip.com/quality.



MICROCHIP

Worldwide Sales and Service

AMERICAS

Corporate Office
2355 West Chandler Blvd.
Chandler, AZ 85224-6199
Tel: 480-792-7200
Fax: 480-792-7277
Technical Support:
<http://www.microchip.com/support>
Web Address:
www.microchip.com

Atlanta

Duluth, GA
Tel: 678-957-9614
Fax: 678-957-1455

Austin, TX

Tel: 512-257-3370

Boston

Westborough, MA
Tel: 774-760-0087
Fax: 774-760-0088

Chicago

Itasca, IL
Tel: 630-285-0071
Fax: 630-285-0075

Dallas

Addison, TX
Tel: 972-818-7423
Fax: 972-818-2924

Detroit

Novi, MI
Tel: 248-848-4000

Houston, TX

Tel: 281-894-5983

Indianapolis

Noblesville, IN
Tel: 317-773-8323
Fax: 317-773-5453
Tel: 317-536-2380

Los Angeles

Mission Viejo, CA
Tel: 949-462-9523
Fax: 949-462-9608
Tel: 951-273-7800

Raleigh, NC

Tel: 919-844-7510

New York, NY

Tel: 631-435-6000

San Jose, CA

Tel: 408-735-9110
Tel: 408-436-4270

Canada - Toronto

Tel: 905-695-1980
Fax: 905-695-2078

ASIA/PACIFIC

Australia - Sydney
Tel: 61-2-9868-6733

China - Beijing
Tel: 86-10-8569-7000

China - Chengdu
Tel: 86-28-8665-5511

China - Chongqing
Tel: 86-23-8980-9588

China - Dongguan
Tel: 86-769-8702-9880

China - Guangzhou
Tel: 86-20-8755-8029

China - Hangzhou
Tel: 86-571-8792-8115

China - Hong Kong SAR
Tel: 852-2943-5100

China - Nanjing
Tel: 86-25-8473-2460

China - Qingdao
Tel: 86-532-8502-7355

China - Shanghai
Tel: 86-21-3326-8000

China - Shenyang
Tel: 86-24-2334-2829

China - Shenzhen
Tel: 86-755-8864-2200

China - Suzhou
Tel: 86-186-6233-1526

China - Wuhan
Tel: 86-27-5980-5300

China - Xian
Tel: 86-29-8833-7252

China - Xiamen
Tel: 86-592-2388138

China - Zhuhai
Tel: 86-756-3210040

ASIA/PACIFIC

India - Bangalore
Tel: 91-80-3090-4444

India - New Delhi
Tel: 91-11-4160-8631

India - Pune
Tel: 91-20-4121-0141

Japan - Osaka
Tel: 81-6-6152-7160

Japan - Tokyo
Tel: 81-3-6880-3770

Korea - Daegu
Tel: 82-53-744-4301

Korea - Seoul
Tel: 82-2-554-7200

Malaysia - Kuala Lumpur
Tel: 60-3-7651-7906

Malaysia - Penang
Tel: 60-4-227-8870

Philippines - Manila
Tel: 63-2-634-9065

Singapore
Tel: 65-6334-8870

Taiwan - Hsin Chu
Tel: 886-3-577-8366

Taiwan - Kaohsiung
Tel: 886-7-213-7830

Taiwan - Taipei
Tel: 886-2-2508-8600

Thailand - Bangkok
Tel: 66-2-694-1351

Vietnam - Ho Chi Minh
Tel: 84-28-5448-2100

EUROPE

Austria - Wels
Tel: 43-7242-2244-39
Fax: 43-7242-2244-393

Denmark - Copenhagen
Tel: 45-4485-5910
Fax: 45-4485-2829

Finland - Espoo
Tel: 358-9-4520-820

France - Paris
Tel: 33-1-69-53-63-20
Fax: 33-1-69-30-90-79

Germany - Garching
Tel: 49-8931-9700

Germany - Haan
Tel: 49-2129-3766400

Germany - Heilbronn
Tel: 49-7131-72400

Germany - Karlsruhe
Tel: 49-721-625370

Germany - Munich
Tel: 49-89-627-144-0
Fax: 49-89-627-144-44

Germany - Rosenheim
Tel: 49-8031-354-560

Israel - Ra'anana
Tel: 972-9-744-7705

Italy - Milan
Tel: 39-0331-742611
Fax: 39-0331-466781

Italy - Padova
Tel: 39-049-7625286

Netherlands - Drunen
Tel: 31-416-690399
Fax: 31-416-690340

Norway - Trondheim
Tel: 47-7288-4388

Poland - Warsaw
Tel: 48-22-3325737

Romania - Bucharest
Tel: 40-21-407-87-50

Spain - Madrid
Tel: 34-91-708-08-90
Fax: 34-91-708-08-91

Sweden - Gothenberg
Tel: 46-31-704-60-40

Sweden - Stockholm
Tel: 46-8-5090-4654

UK - Wokingham
Tel: 44-118-921-5800
Fax: 44-118-921-5820