



Audible + Visual > Tri - Colour LED PLC Controllable Beacon

Product overview

The Spectrum 600 Series utilises ultra-bright, tri-colour LEDs in one enclosure producing amber, green and red light in conjunction with two synchronised piezo sounders. The beacon is a cost-effective alternative to traditional stacking beacons and other process indication applications where multiple signal outputs, long life and low power consumption are

required. The Spectrum 600 comes totally assembled and ready for immediate installation. In addition, the enclosure incorporates a high Ingress Protection (IP) rating and is manufactured from a tough, UV stable polycarbonate plastic that makes the beacon suitable for harsh industrial and marine environments. The Spectrum 600 requires external input signals for it to function. If no PLC (or similar) is available, then the Spectrum Interface Unit gives the end user a control option.

Features

Three colours in one housing – **amber red green**

360° visibility

LED long life and low power

Combined beacon & piezo sounders

28 signal options

PLC controllable

Optional interface unit for non PLC operation – 7 preset signals

Ethernet compatible

Tough, UV stable polycarbonate housing

Code No:	Voltage:	Light Source:	Current:	
			Amber	Red/Green
LEDA600-01	24v Dc/230v Ac ---	Tri-Colour LED	450 mA	265 mA
LEDA600-03	24v Dc/115v Ac ---	Tri-Colour LED	450mA	265 mA
50165 Interface	230v Ac			
50166 Mounting Pole				
50004 Right-angled Wall Bracket				

Material

UV Stable Polycarbonate Plastic



Kg 0.85

°C -35+55

IP 65 66 67 69K

IP 68 option

Hz 50/60

dB 90

MARINE

INDUSTRIAL

FPM 60x90

APPROVAL AND CONFORMITIES



Visual Signals LIGHT EMITTING DIODE

BEACONS

The Control Signal

The Control Signal must consist of a 5-bit word, which has to be assembled and transmitted in parallel mode to the Spectrum Beacon. The colour, flash frequency

and sound are independent of one another but a colour signal is necessary for the control word to be accepted, thus any word beginning with 00 will not be accepted.

50165 Interface Unit (Optional)

for further information download Interface Data Sheet from the website

The Interface Unit contains seven electrically isolated prioritised channels. Each channel accepts 24-230v Ac or 12-48v Dc input. A pre-selected audio and/or visual signal is supplied for each of the seven channels. In the event of no signal being applied, the beacon displays continuous green. The operating voltage for the unit is 230v Ac. The design allows for a 12v Dc auxiliary

power supply for use in volt free applications. Additionally, the unit incorporates a battery [not supplied] back-up sufficient to maintain the unit for 12 hours in case of mains power failure. Provision is made for mains failure to be signalled from the interface unit (device not supplied). The unit is supplied complete with mounting plate and cover. This can be installed either inside an existing enclosure or into a standard weatherproof 'Fibox' IP67 mounting box [ref. MNX PCM200/63 G].

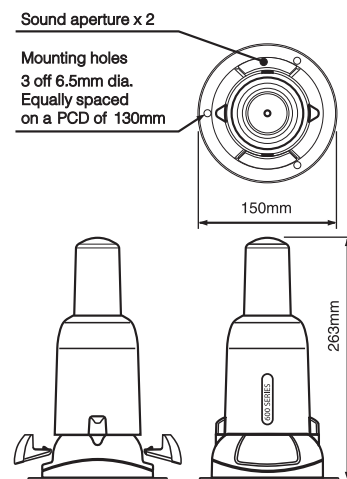

Optional IP66
Sounder covers

Technical Specification

Type	LEDA600-01	24v Dc or 230v Ac
	LEDA600-03	24v Dc or 115v Ac
Light Source	Ultra-bright Tri-colour LEDs	
	Amber	3.9 Effective Candela (390 mcd) 450mA
	Green	6.2 Effective Candela (620 mcd) 265mA
	Red	4.4 Effective Candela (440 mcd) 265mA
Signal Options	Continuous	ON
	Slow Flash	60 fpm
	Rapid Flash 1	90 fpm (0.11sec ON, 0.23 OFF)
	Rapid Flash 2	90 fpm (0.23sec ON, 0.11 OFF)
Sounder Type	Electronic Piezo Sounders x 2 : 20mA	
	db@1m	90dB ±3dB (horn covers not installed)
	Frequency	3.1Hz ±500Hz
	Visual and audible signalling options can be combined – audible signal synchronised with beacon flash	
Operating Temp	-35°C to +55°C	Weight 0.85 kg
Enclosure Material	UV Stable Polycarbonate Plastic	
Ingress Protection	IP65 & IP67 as standard as one enclosure. IP66 with sounder covers fitted. Sounder covers can be fitted (snap-fixed) or permanently (adhered) into place. Sounder covers supplied as standard.	
Beacon Control	The beacon is supplied with flying leads 2 x 1 metre 4 core power cables and 6 core signal cables. For further information download the Technical Data Sheet from our website.	

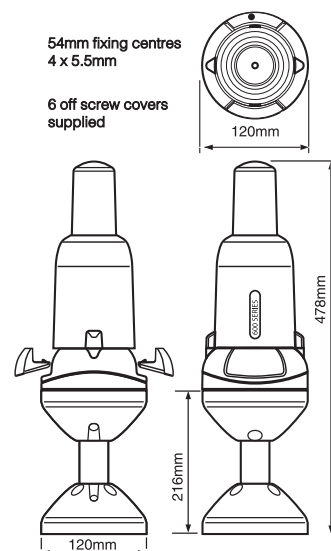

Mounting Options

The beacon has three mounting options:

Surface Mount Plate
(3 point DIN fix) fitted as standard
Side knockouts x 2 cabling in/out
(15mm x 10mm)

Foot and Pole Mount (50166)

Right Angled Wall Bracket (50004)