



SERIES 77
Lipped, 45° Angle Shrink Boots
 770-003B Angled Boot
 How to Order



45° Boots



Lipped, 45° angle heat shrink boots provide mechanical and environmental protection from damage and debris. These shrink boots fit most standard boot adapters for circular connectors. All adhesive lined and unlined shrink boots are RoHS compliant. Shrink boots are water-tight when equipped with factory installed or user-installed adhesive. Lipped boots lock into boot groove located on adapter. Choose boot size based on adapter diameter and cable diameter.

How to Order

Sample Part Number	770	-003	B	1	03	W1	-PP
Product Series	770 = Series 77 shrink boot						
Basic Number	003 = lipped, boot						
Angular Function	B = 45°						
Material	See material and adhesive compatibility table						
Boot Size	03, 04, 05, 06, 07; see dimensions table						
Adhesive Lined	Omit for no adhesive; see material and adhesive compatibility table						
Potting Port	PP = potting port Omit for none						

Material and Adhesive Compatibility

Material Code	Material Description (Compound No.)	Hot Melt Adhesives			High Performance Epoxy Adhesives		
		W1	W2	W3 (TACOM approved)	R	U	
		High Temperature -55°C to 125°C	Standard -55°C to 70°C	Elastomeric -55°C to 125°C	Pre-Coat -75°C to 150°C	Two-Part -75°C to 155°C	
1	High-Performance Semi-Rigid Elastomer (2025)	●	●		●	Type U epoxy adhesive is compatible with all boot materials. Ordered separately, user-installed (779-001). Order boot with no adhesive lining.	
2	Zero Halogen Semi-Rigid Polyolefin (2010)	●	●		●		
3	General Purpose Flexible Polyolefin (2040)		●				
5	Viton Fluoroelastomer Blend (2050)	●		●	●		
6	High Performance Elastomer Alloy (2051)	●		●			
7	Semi-Rigid Polyolefin (2071)	●	●				
8	Low Outgassing Fluoropolymer Alloy (2008)	Material Type 8 not available with pre-coat adhesive. Use Type U two-part epoxy					
9	Low Temp Flexible Polyolefin (2013)		●				

NOTES

1. See **Modification Codes** listed in Section A for material color options available for **Type 1 (compound 2025)** material.



SERIES 77

Lipped, 45° Angle Shrink Boots

770-003B Angled Boot
Dimensions



Lipped 45° Angle Shrink Boots: Dimensions

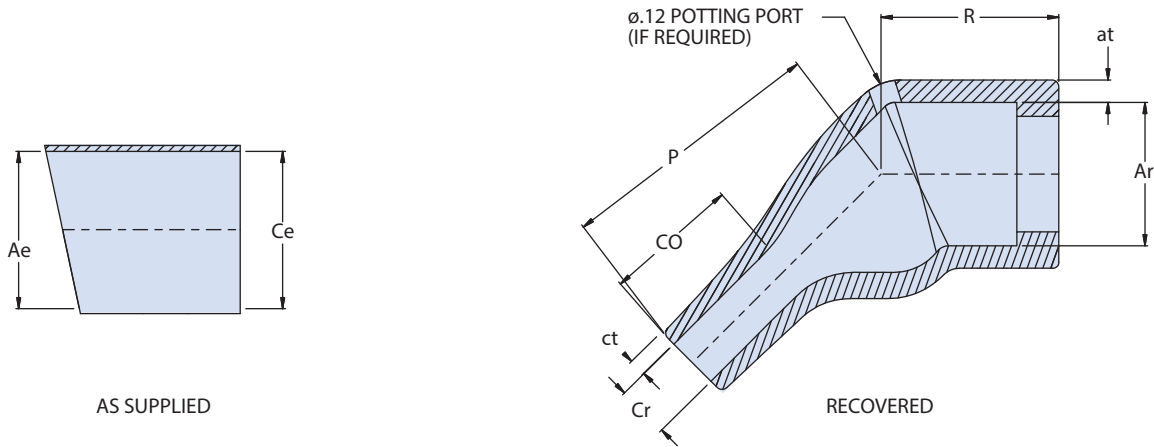

45° Boots

C

Dimensions											
Boot Size	Glenair US Part Marking	Shell Size	Ae Dia. Min	Ce Dia. Min	Ar Dia Max	at ±30%	Cr Dia. Max	ct ±20%	CO Ref	P ±10%	R Ref
03	B03	9	.945 (24.0)	.945 (24.0)	.413 (10.5)	.063 (1.6)	.157 (4.0)	.035 (0.9)	.315 (8.0)	.748 (19.0)	.500 (12.7)
04	B04	11 - 15	1.181 (30.0)	1.181 (30.0)	.551 (14.0)	.071 (1.8)	.236 (6.0)	.039 (1.0)	.354 (9.0)	1.180 (30.0)	.748 (19.0)
05	B05	13 - 17	1.260 (32.0)	1.260 (32.0)	.709 (18.0)	.079 (2.0)	.276 (7.0)	.071 (1.8)	.591 (15.0)	1.378 (35.0)	.984 (25.0)
06	B06	17 - 21	1.417 (36.0)	1.417 (36.0)	.866 (22.0)	.079 (2.0)	.335 (8.5)	.071 (1.8)	.709 (18.0)	1.575 (40.0)	1.260 (32.0)
07	B07	21 - 23	1.693 (43.0)	1.693 (43.0)	1.102 (28.0)	.087 (2.2)	.394 (10.0)	.079 (2.0)	.709 (18.0)	1.772 (45.0)	1.496 (38.0)

Lipped 45° Angle Shrink Boots: Part Marking, Raised Lettering

