

- Lifetime Warranty
- UL508 Approved
- SEMI F47 Compliant (high line AC)
- Universal Input (85 - 265VAC)
- High Efficiency
- RoHS Compliant Design

HWS300-1500 Series

Single Output Industrial Power Supplies

Key Market Segments & Applications

Factory Automation:
 Test & Measurement:
 Automated Service

HWS300-1500 Features and Benefits

Features

- Lifetime Warranty
- High Efficiency
- Wide Range AC Input

Benefits

- Lower Cost of Ownership
- Easier System Cooling
- Supports Global Use

Specifications

ITEMS	MODEL	HWS300	HWS600	HWS1000	HWS1500
Input Voltage range (47-63Hz)	-	85 - 265VAC or 120 - 330VDC			85 - 265VAC
Input Current (Typ) (1)	A	5V: 3.8/1.9; 12-48V: 4.2/2.1	5V: 7.5/3.6; 12-48V: 8.1/3.9	3.3V: 9.6/5.0; 5-60V: 13.5/7.0	19/10
Inrush Current (1)	A	20 / 40			
Power Factor	-	Meets EN61000-3-2			
Temperature Coefficient	-	<0.02%/°C			
Overcurrent Protection	-	> 105% (> 101% of peak current for peak current capable models)			
Overvoltage Protection	V	See table on page 2 (Recycle AC or remote on/off to reset)			
Hold Up Time (Typ)	ms	20			
Leakage Curr. (at 240VAC, 60Hz)	mA	<0.75mA	<1.2mA	<1.5mA	<1.5mA
Remote Sense	-	Yes			
Indicator	-	Green LED = ON			
Remote on/off	-	Yes (Isolated from output)			
Parallel operation	-	Single wire connection (up to 5 units)			
DC Good	-	Yes			
Remote Adjust (PV)	-	External voltage adjusts output, see options table			
Operating Temperature	-	-10°C to +70°C, derate linearly to 50% load from 50C to 70C (2, 3)			
Storage Temperature	°C	-30 to +85°C			
Humidity (non condensing)	-	Operating: 10 - 90%RH, Non operating 10 - 95%RH			
Cooling	-	Internal fan			
Withstand Voltage (4)	-	Input to Ground 2.5kVAC, Input to Output 3kVAC, Output to Ground 500VAC for 1 min.			
Isolation Resistance	-	> 100M at 25C & 70%RH, Output to Ground 500VDC			
Vibration (non operating)	-	- 10 - 55Hz (1 minute sweep), 19.6m/s ² constant X, Y, Z 1 hour			
Shock	-	< 196.1 m/s ²			
Safety Agency Approvals (5)	-	UL60950-1, CSA60950-1, EN60950-1, EN50178, UL508, CE Mark			
Line Dip	-	Complies with SEMI F47 (200VAC line only)			
Conducted & Radiated EMI	-	EN55011 / EN55022, FCC VCCI (HWS300, 600 & 1000: Class B, HWS1500: Class A)			
Recommended EMI Filter	-	MC1206	MC1210	MC1220	MC1230
Immunity	-	IEC61000-4-2, -3, -4, -6 (Level 3), -5, -8 (Level 4), -11			
Weight (Typ)	g	1,000	1,600	3,200	3,800
Size	mm	61 x 82 x 165	100 x 82 x 165	240 x 126.5 x 82	280 x 126.5 x 82
Warranty	-	Lifetime Warranty (See Lambda's terms & conditions)			

Notes:

- (1) 100/200VAC
 (2) HWS start up -20°C. (-40°C see options table)
 (3) HWS1000/1500 with 85VAC input: See installation manual

- (4) 2kVAC HWS1000/1500 Input to ground
 (5) UL60601-1, EN60601-1, see options.
 UL508; HWS300/600 5V, 12V, 24V & 48V models

Output Ratings

Model	Voltage V	Adjust Range V(3)	Max Curr. A	Peak Curr. A(2)	Max. Pwr. W	Load Reg mV	Line Reg mV	Ripple Noise mV	Over-voltage V	Eff. typ % (1)
HWS300-3	3.3V	2.64 - 3.96	60	-	198	30	20	120	4.13 - 4.95	74/77
HWS600-3	3.3V	2.64 - 3.96	120	-	396	30	20	120	4.13 - 4.95	75/78
HWS1000-3	3.3V	2.64 - 3.96	200	-	660	40	20	120	4.13 - 4.62	71/73
HWS300-5	5V	4 - 6	60	-	120	30	20	120	6.25 - 7.25	79/82
HWS600-5	5V	4 - 6	120	-	600	30	20	120	6.25 - 7.25	80/83
HWS1000-5	5V	4 - 6	200	-	1000	40	20	120	6.25 - 7	76/78
HWS1000-6	6V	4.8 - 7.2	167	-	1002	60	36	150	7.5 - 8.4	79/81
HWS1000-7	7.5V	6 - 9V	134	160	1005	60	36	150	9.38 - 10.5	80/82
HWS300-12	12V	9.6 - 14.4	27	-	324	96	48	120	15 - 17.4	80/83
HWS600-12	12V	9.6 - 14.4	53	-	648	96	48	120	15 - 17.4	80/83
HWS1000-12	12V	9.6 - 14.4	88	100	1056	100	48	150	15 - 17.4	83/85
HWS1500-12	12V	9.6 - 14.4	125	-	1500	72	48	150	15 - 17.4	82/85
HWS300-15	15V	12 - 18	22	-	330	120	60	150	18.8 - 21.8	82/85
HWS600-15	15V	12 - 18	43	-	645	120	60	150	18.8 - 21.8	82/85
HWS1000-15	15V	12 - 18	70	80	1050	120	60	150	18.8 - 21.8	83/85
HWS1500-15	15V	12 - 18	100	-	1500	90	60	150	18.7 - 21.8	83/87
HWS300-24	24V	19.2 - 28.8	14	16.5	336	192	96	150	30 - 34.8	82/85
HWS600-24	24V	19.2 - 28.8	27	31	648	192	96	150	30 - 34.8	82/85
HWS1000-24	24V	19.2 - 28.8	44	50	1056	150	96	150	30 - 34.8	85/87
HWS1500-24	24V	19.2 - 28.8	65/70 (1)	105	1560	144	96	200	30 - 34.8	84/88
HWS1000-36	36V	28.8 - 43.2	29.3	33.3	1055	150	144	200	45 - 49.7	85/88
HWS1500-36	36V	28.8 - 43.2	42/46.5 (1)	70	1512	150	144	200	45 - 49.7	84/88
HWS300-48	48V	38.4 - 52.8	7	-	336	384	192	200	55.2 - 64.8	82/85
HWS600-48	48V	38.4 - 52.8	13	-	624	384	192	200	55.2 - 64.8	82/85
HWS1000-48	48V	38.4 - 52.8	22	25	1056	300	192	200	38.4 - 52.8	86/88
HWS1500-48	48V	38.4 - 52.8	32	-	1536	288	192	200	55.2 - 64.8	86/90
HWS1000-60	60V	48 - 66	17.6	20	1056	360	240	400	69 - 75	85/88

Notes

(1) 100/200VAC

(2) 200-265VAC Input, 10s maximum on time with 35% duty cycle

(3) Use program input (PV) to adjust from 20-120% of nominal (20-110% for 48V models)

Options

Suffix	Description
Blank	HWS300-1500 the cover is fitted as standard
/A	Not Applicable
/PV	HWS300, 600 (Standard on HWS1000 & 1500): 1-6V program voltage input to adjust output 20-120% of nominal (20-110% for 48V) (12V-48V models only)
/HD	See HWS50-1500/HD Datasheet for details. -40 to +71(74)°C operation, conformally coated PCBs
/ME	See HWS30-1500/ME Datasheet for details. UL60601-1, EN60601-1 medical approvals

HWS300 Outline Drawing

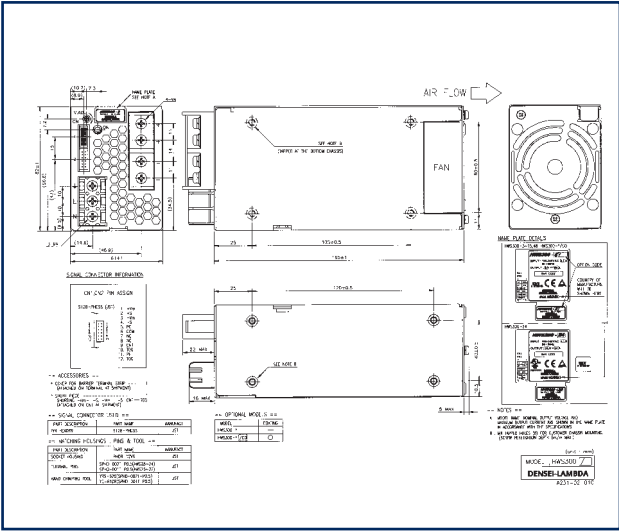

HWS600 Outline Drawing

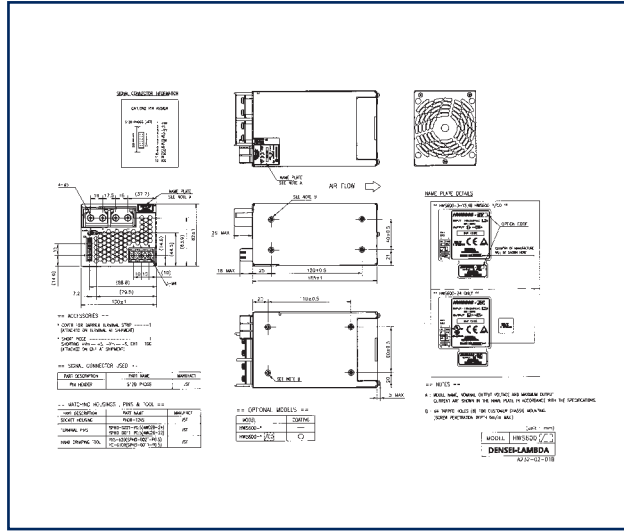

HWS1000 Outline Drawing

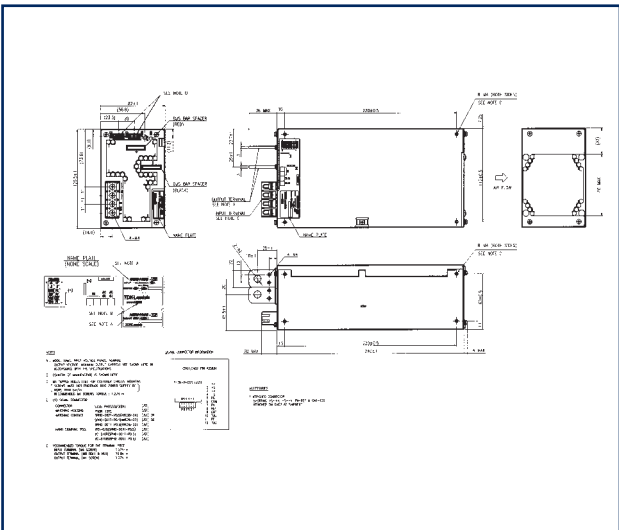

HWS1500 Outline Drawing

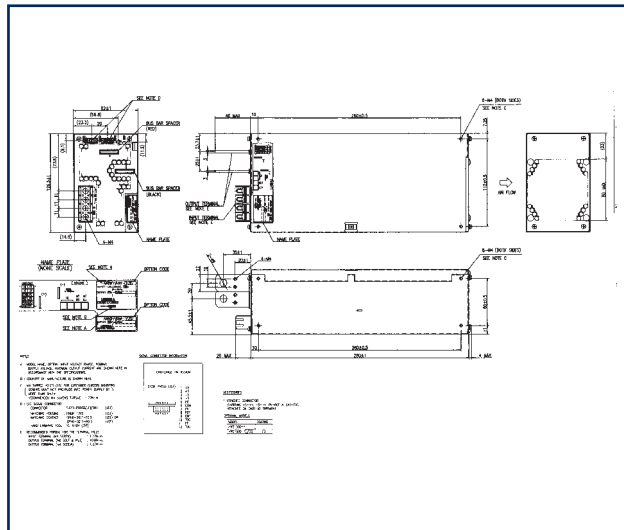

LAMBDA EUROPE

AUSTRIA

LAMBDA ELECTRONICS GmbH
Aredstraße 22
A-2544 Leobersdorf

Telephone: +43 (0) 2256 655 84
Facsimile: +43 (0) 2256 645 12
www.lambda-austria.com

FRANCE

LAMBDA SAS
ZAC des Delaches, BP1077 - Gometz le Chatel
91940 Les Ulis

Telephone: +33 (0) 1 60 12 71 65
Facsimile: +33 (0) 1 60 12 71 66
Web: www.lambda-f.com

GERMANY

LAMBDA GmbH
Karl-Bold-Straße 40
D-77855 Achern

Telephone: +49 (0) 78 41 666 0
Facsimile: +49 (0) 78 41 5000
Web: www.lambda-germany.com

ISRAEL

NEMIC LAMBDA LTD
Kibbutz Givat
Hashlosa 48800

Telephone: +972 (0) 3 902 4333
Facsimile: +972 (0) 3 902 4777
Web: www.nemic.co.il

ITALY

LAMBDA s.r.l.
Via dei Laboratori 128/130,
20092, Cinisello Balsamo (Mi)

Telephone: +39 (0) 02 61 29 38 63
Facsimile: +39 (0) 02 61 29 09 00
Web: www.lambda-italy.com

SWEDEN

LAMBDA SCANDINAVIA
PO Box 546, Rallarvägen 41
SE-184 25. Akersberga

Telephone: +46 (0) 8 598 94 090
Facsimile: +46 (0) 8 540 66 096
Web: www.lambda-scandinavia.com

UK

LAMBDA UK
Kingsley Avenue
Ilfracombe Devon EX34 8ES

Telephone: +44 (0) 1271 856666
Facsimile: +44 (0) 1271 864894
Web: www.lambda-gb.com

LAMBDA NORTH AMERICA

visit www.lambdapower.com for a list of Lambda offices and distributors

LAMBDA ASIA

visit www.densei-lambda.com for a list of Lambda offices and distributors

LOCAL DISTRIBUTION

