

SERPAC 171iAC (exploded isometric)

Electronic Enclosures

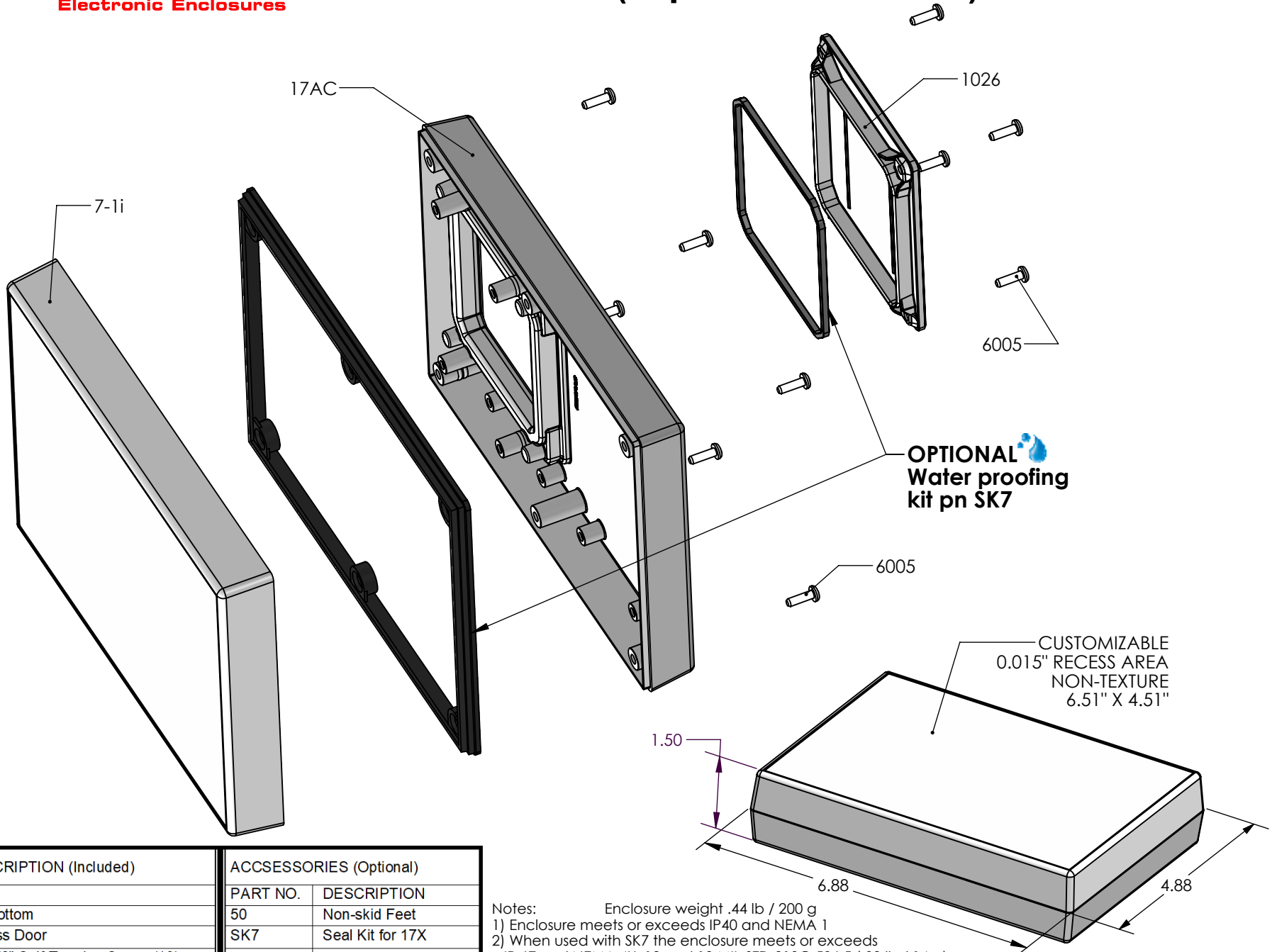

OPTIONAL
Water proofing
kit pn SK7

CUSTOMIZABLE
0.015" RECESS AREA
NON-TEXTURE
6.51" X 4.51"

PART NO.	DESCRIPTION (Included)	ACCESSORIES (Optional)	
7-1i	Top	PART NO.	DESCRIPTION
17AC	AC Bottom	50	Non-skid Feet
1026	Access Door	SK7	Seal Kit for 17X
6005	#4X3/8" Self-Tapping Screw (10)		

Notes: Enclosure weight .44 lb / 200 g
 1) Enclosure meets or exceeds IP40 and NEMA 1
 2) When used with SK7 the enclosure meets or exceeds IP 67 and NEMA 4X, 12 and 13 MIL-STD-810G 506.5 (.03 lb / 14 g)
 3) Circuit Board drawings see sheet 3.
 4) All components are RoHS Compliant.

SERPAC 171iAC

Electronic Enclosures

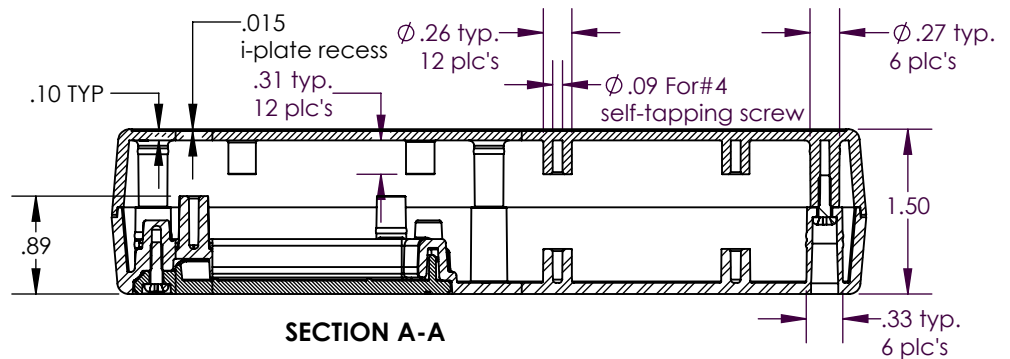
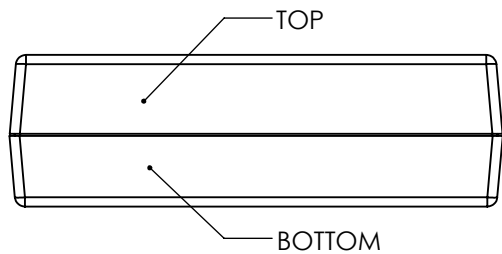
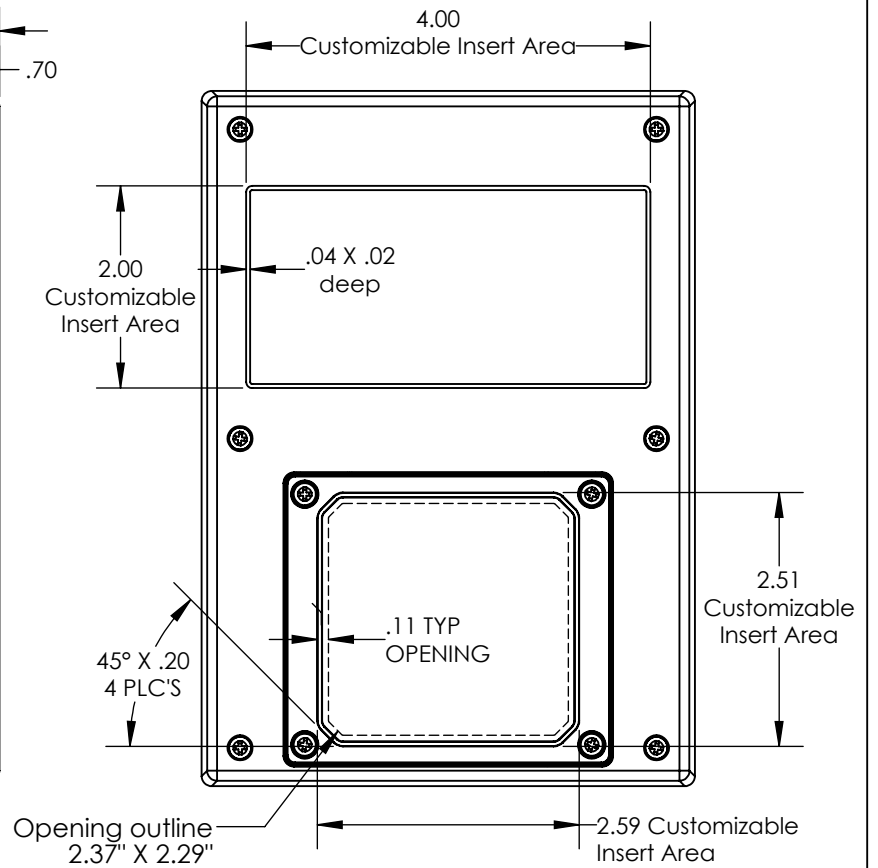
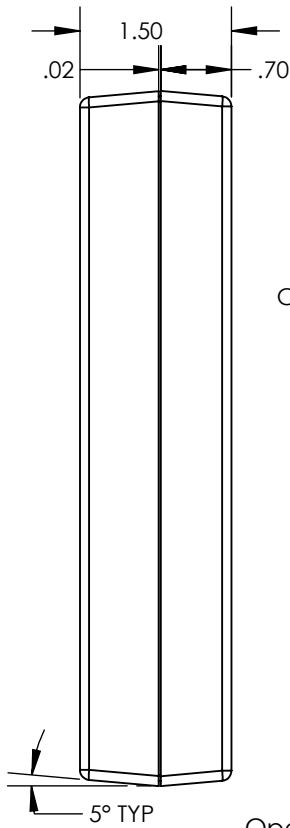
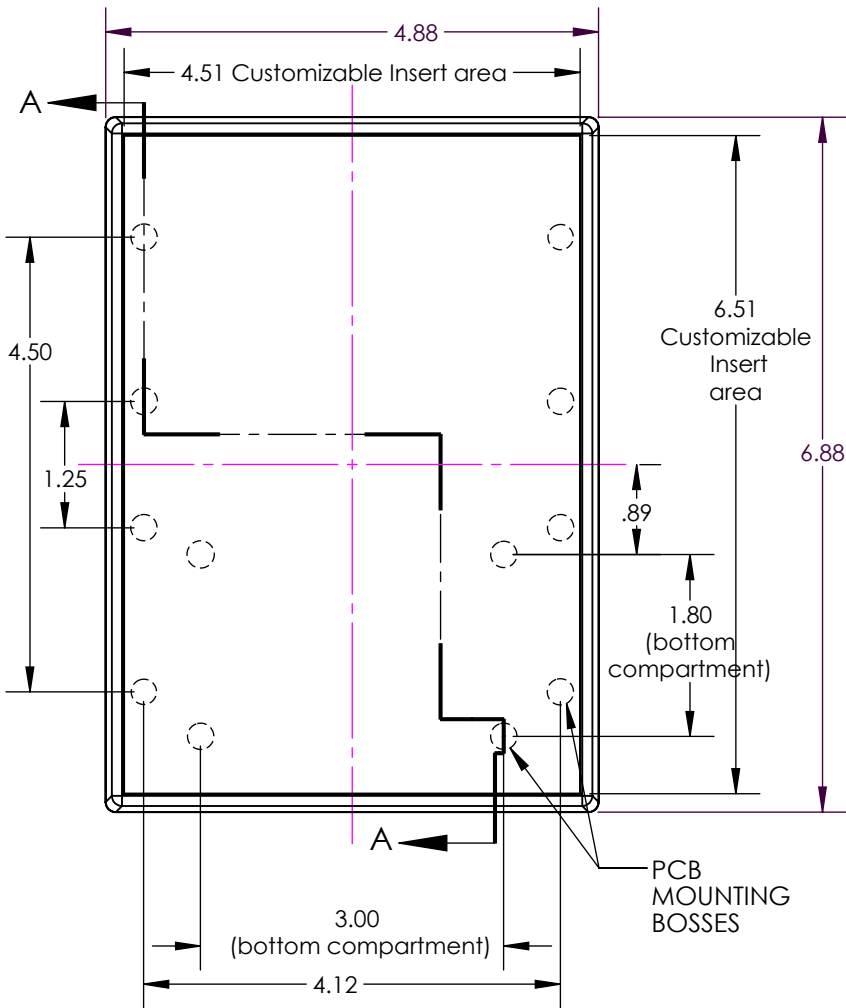

SERPAC PCB for 17X compartment enclosures

Electronic Enclosures

CIRCUIT BOARD FOR TOP

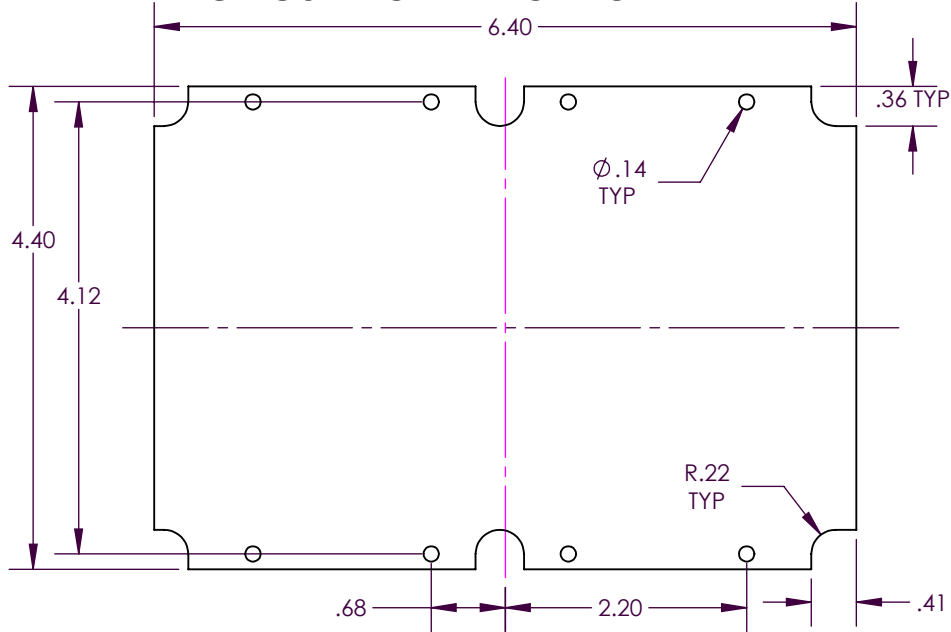

CIRCUIT BOARD FOR BOTTOM

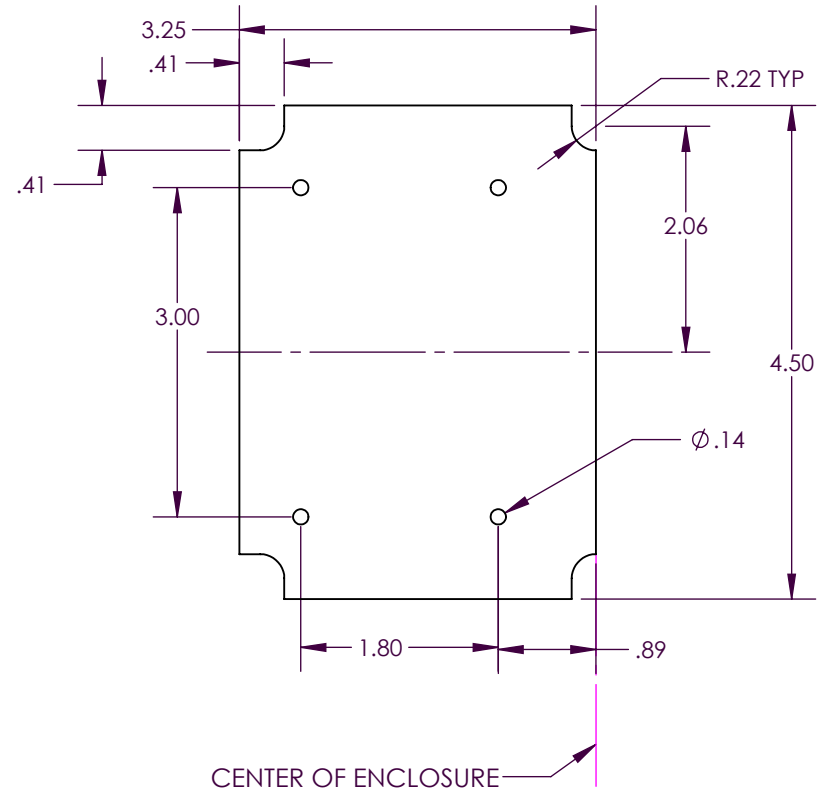

SMALL CIRCUIT BOARD FOR BOTTOM

