

SERPAC 172iAC (exploded isometric)

Electronic Enclosures

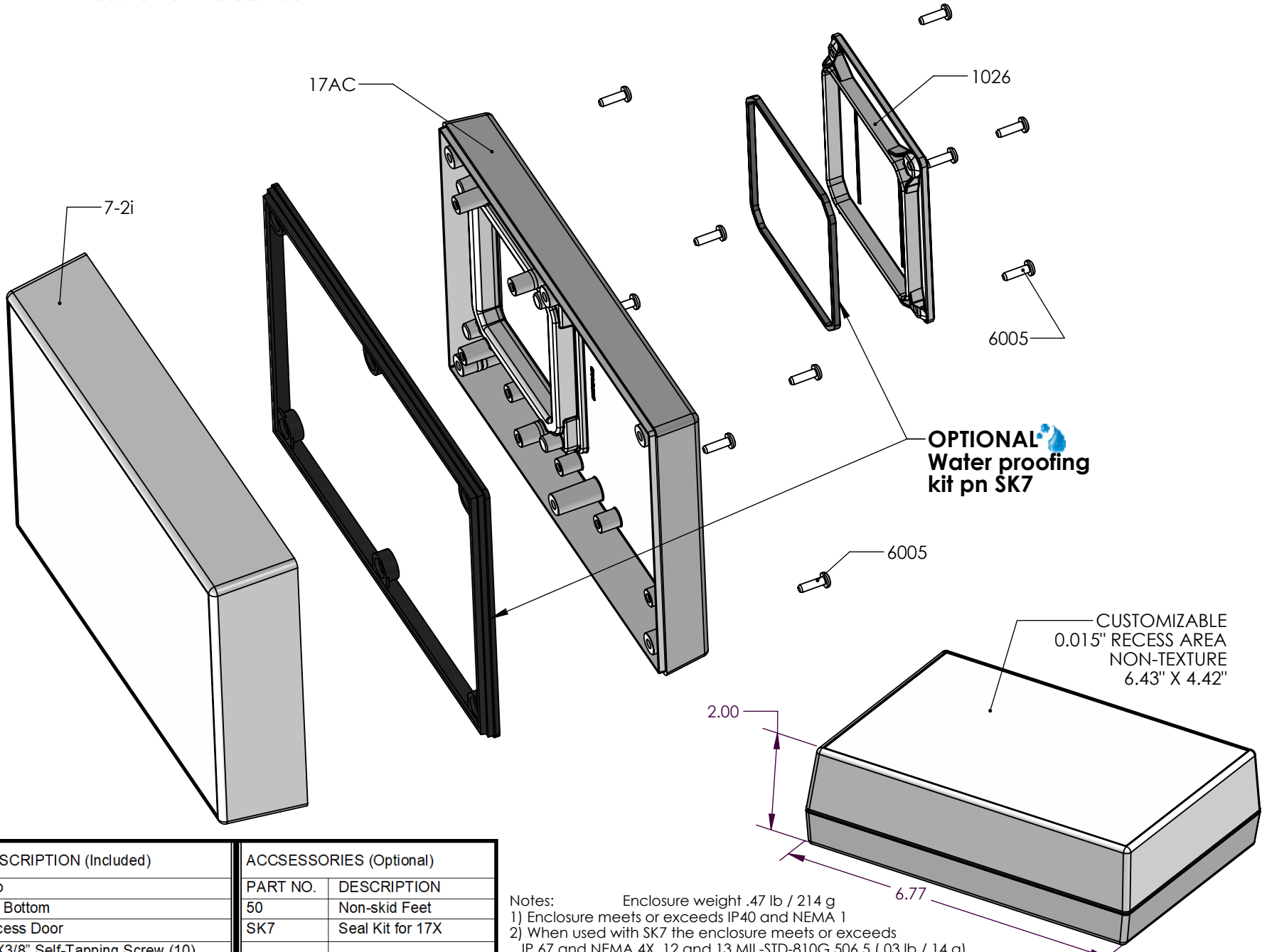

OPTIONAL
Water proofing
kit pn SK7

CUSTOMIZABLE
0.015" RECESS AREA
NON-TEXTURE
6.43" X 4.42"

PART NO.	DESCRIPTION (Included)	ACCESSORIES (Optional)	
7-2i	Top	PART NO.	DESCRIPTION
172AC	AC Bottom	50	Non-skid Feet
1026	Access Door	SK7	Seal Kit for 17X
6005	#4X3/8" Self-Tapping Screw (10)		

Notes: Enclosure weight .47 lb / 214 g
 1) Enclosure meets or exceeds IP40 and NEMA 1
 2) When used with SK7 the enclosure meets or exceeds IP 67 and NEMA 4X, 12 and 13 MIL-STD-810G 506.5 (.03 lb / 14 g)
 3) Circuit Board drawings see sheet 3.
 4) All components are RoHS Compliant.

SERPAC 172iAC

Electronic Enclosures

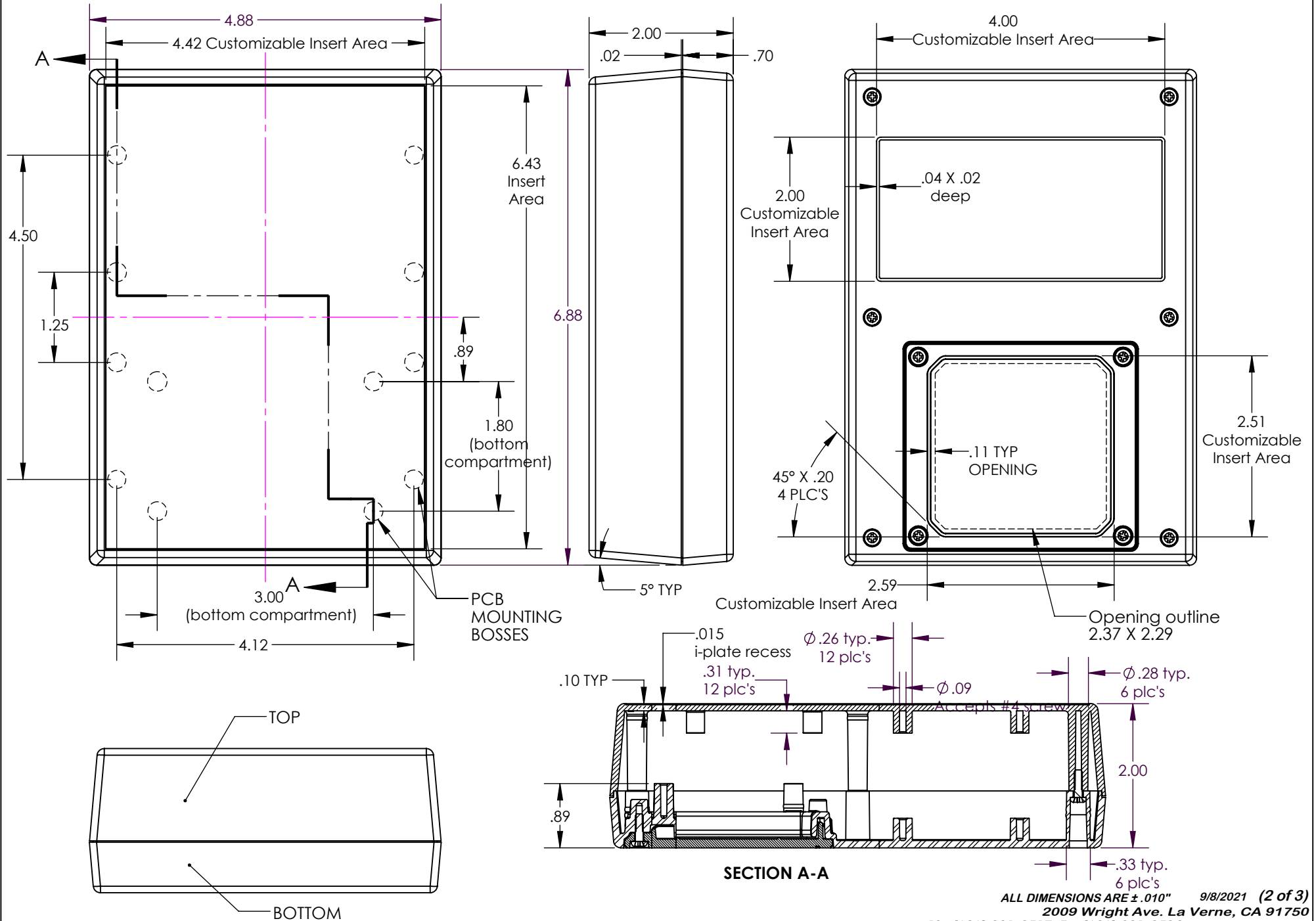

ALL DIMENSIONS ARE ± .010" 9/8/2021 (2 of 3)

2009 Wright Ave. La Verne, CA 91750

Ph. (626) 331-0517 Fx. (626) 331-8584 www.serpac.com

SERPAC PCB for 17X compartment enclosures

Electronic Enclosures

CIRCUIT BOARD FOR TOP

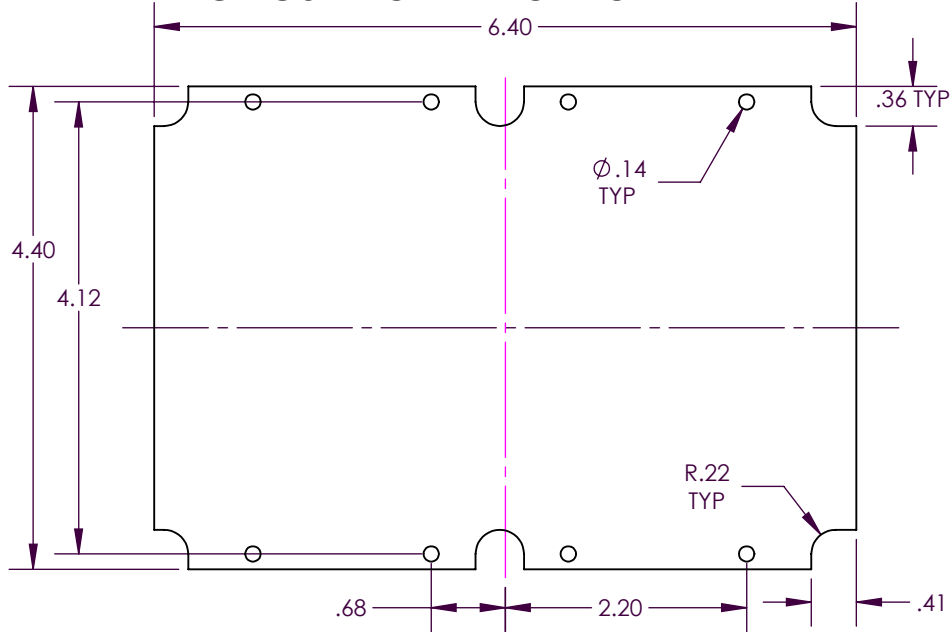

CIRCUIT BOARD FOR BOTTOM

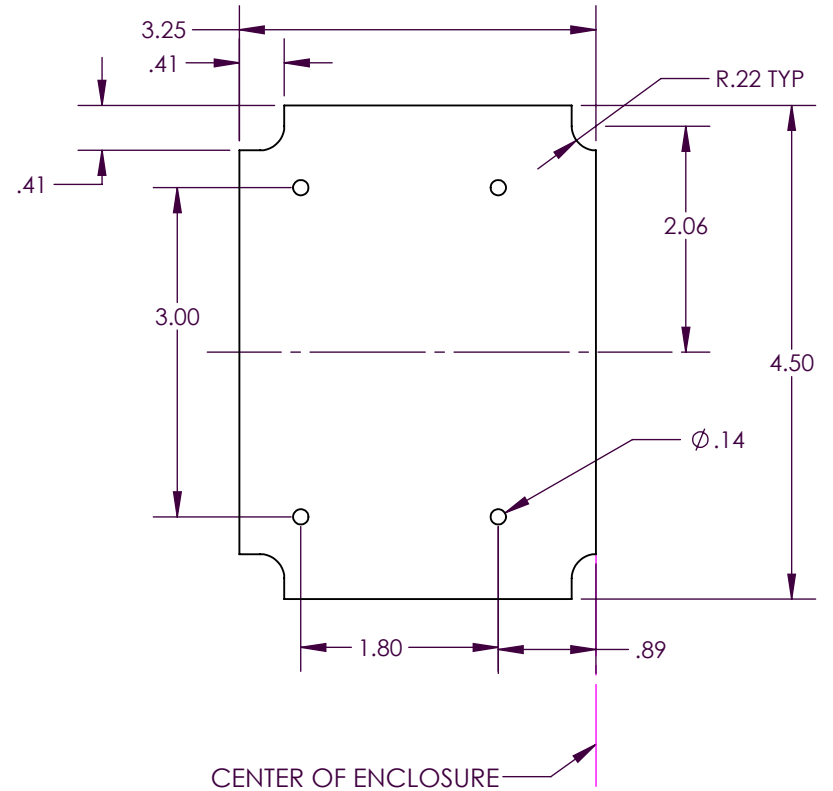

SMALL CIRCUIT BOARD FOR BOTTOM

