

SERPAC 173i2AA (exploded isometric)

Electronic Enclosures

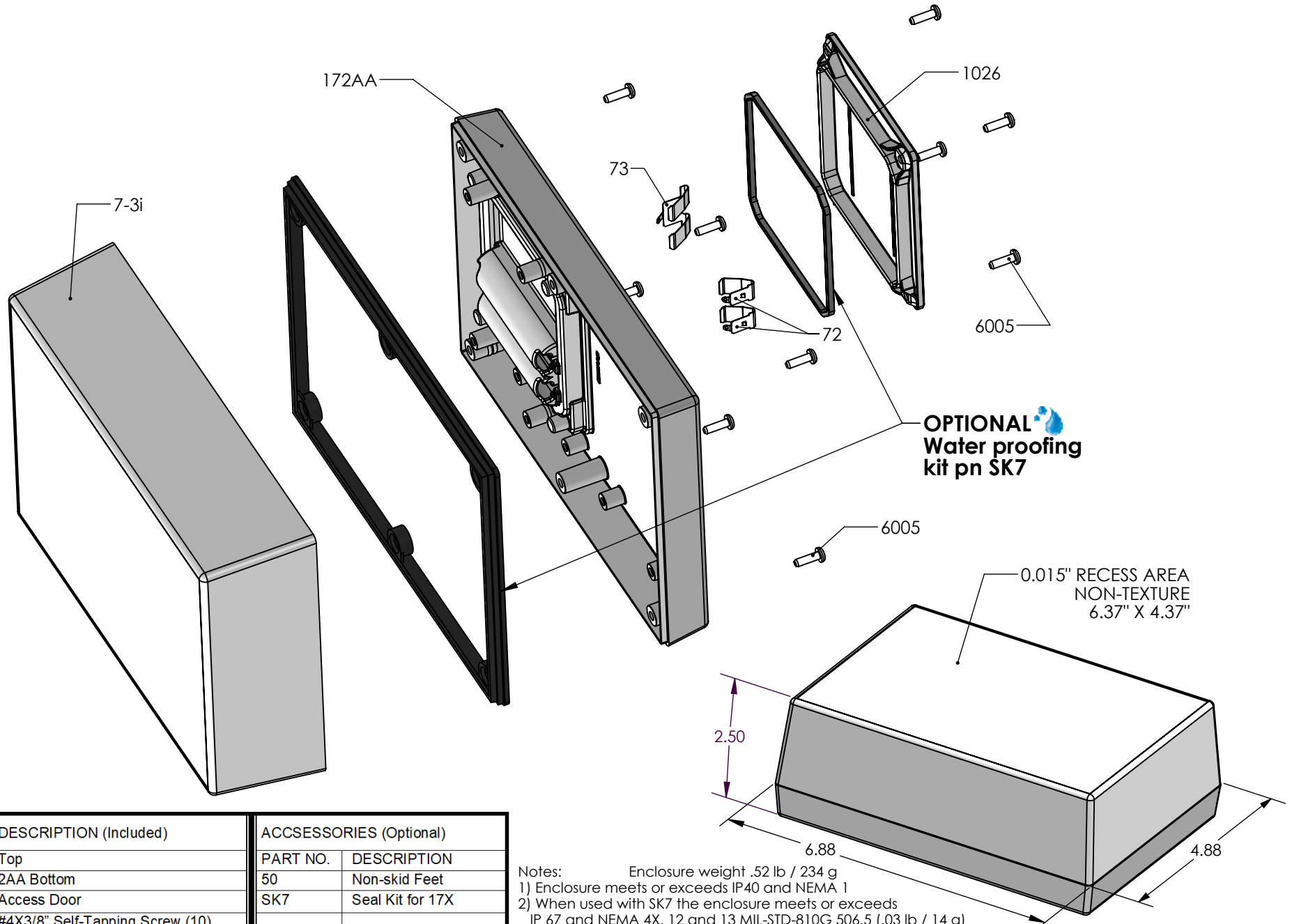

OPTIONAL
Water proofing
kit pn SK7

0.015" RECESS AREA
NON-TEXTURE
6.37" X 4.37"

PART NO.	DESCRIPTION (Included)	ACCESSORIES (Optional)	
7-3i	Top	PART NO.	DESCRIPTION
172AA	2AA Bottom	50	Non-skid Feet
1026	Access Door	SK7	Seal Kit for 17X
6005	#4X3/8" Self-Tapping Screw (10)		
72	Single Battery contact (2)		
73	Double Battery contact		

Notes: Enclosure weight .52 lb / 234 g
 1) Enclosure meets or exceeds IP40 and NEMA 1
 2) When used with SK7 the enclosure meets or exceeds IP 67 and NEMA 4X, 12 and 13 MIL-STD-810G 506.5 (.03 lb / 14 g)
 3) Circuit Board drawings see sheet 3.
 4) All components are RoHS Compliant.

SERPAC 173i2AA

Electronic Enclosures

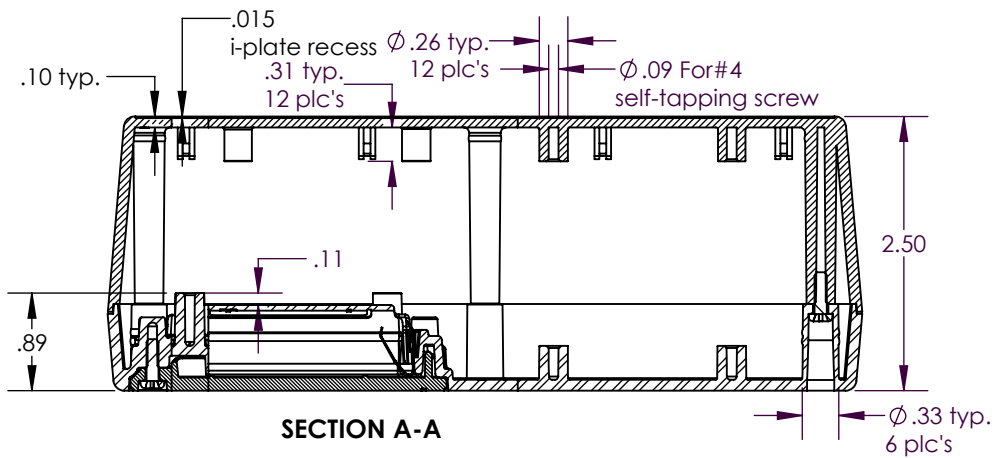
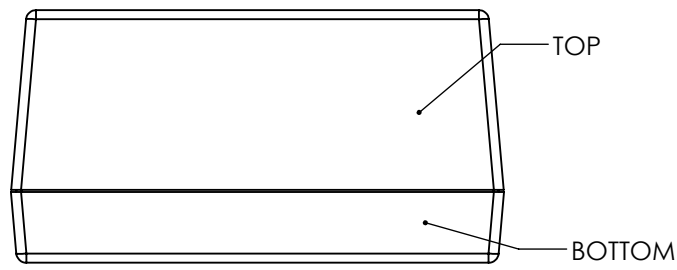
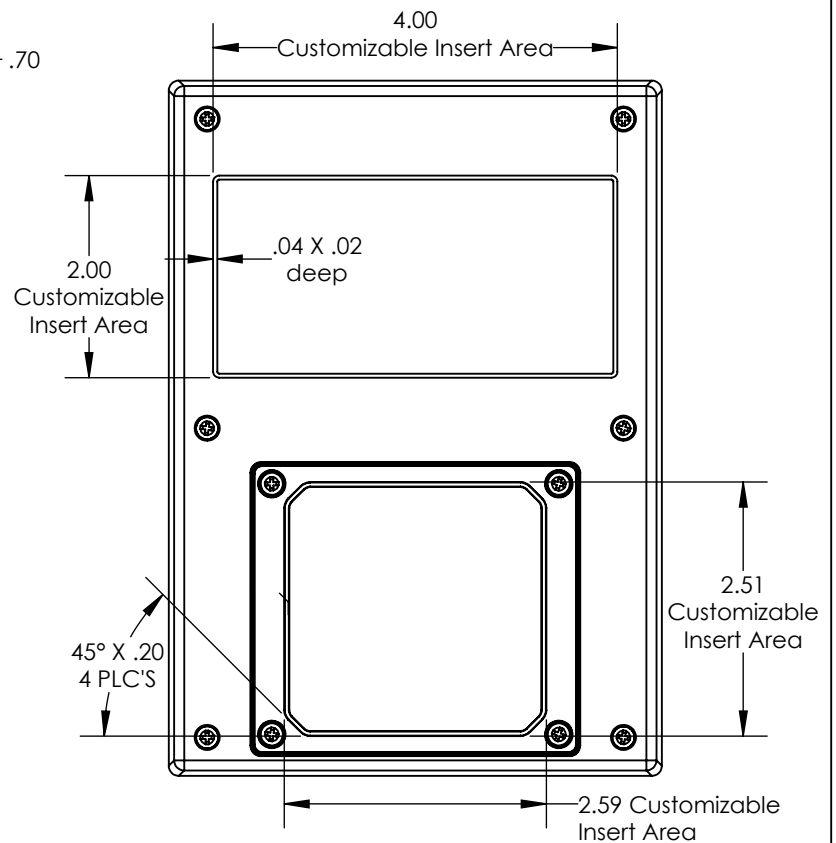
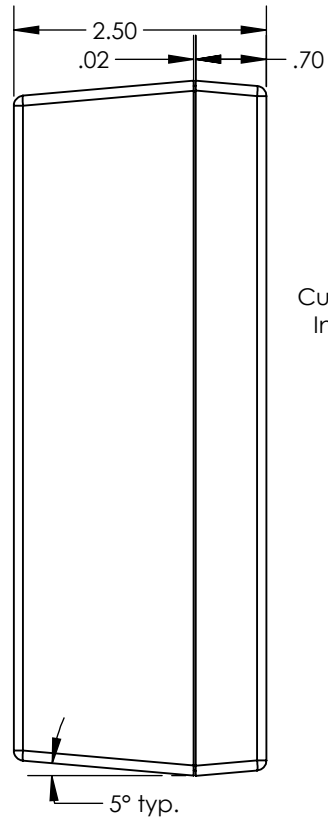
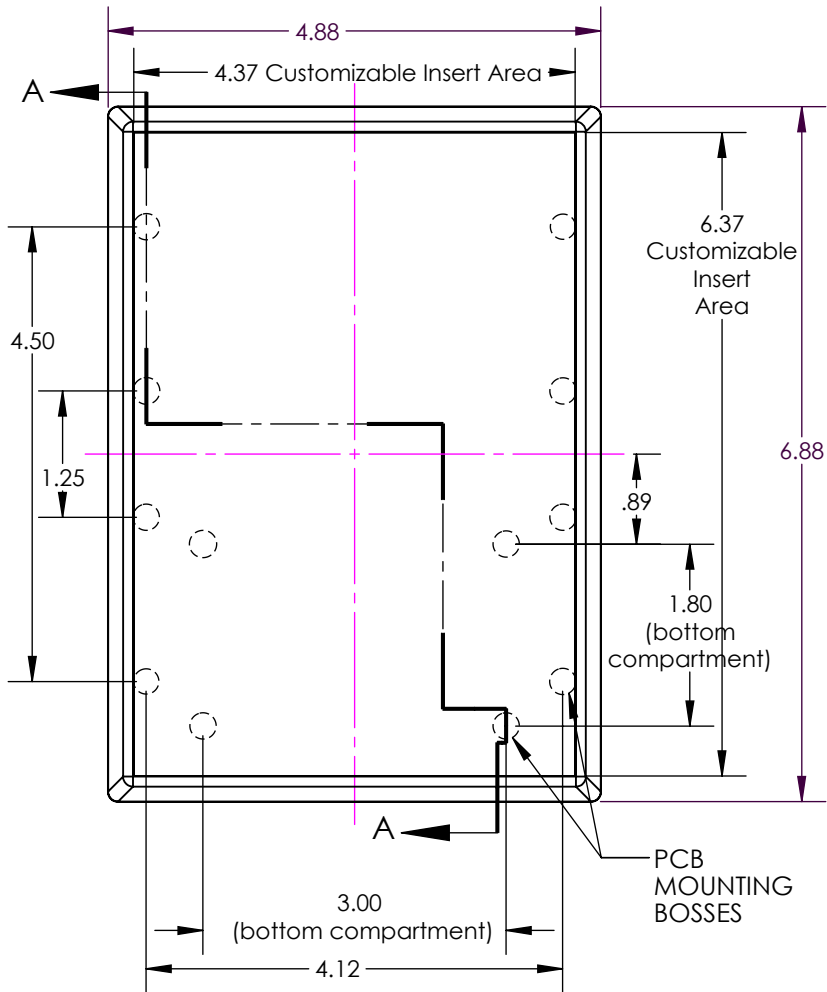

ALL DIMENSIONS ARE ±.010" 9/17/2021 (2 of 3)
2009 Wright Ave. La Verne, CA 91750
Ph. (626) 331-0517 Fx. (626) 331-8584 www.serpac.com

SERPAC PCB for 173 compartment enclosures

Electronic Enclosures

CIRCUIT BOARD FOR TOP

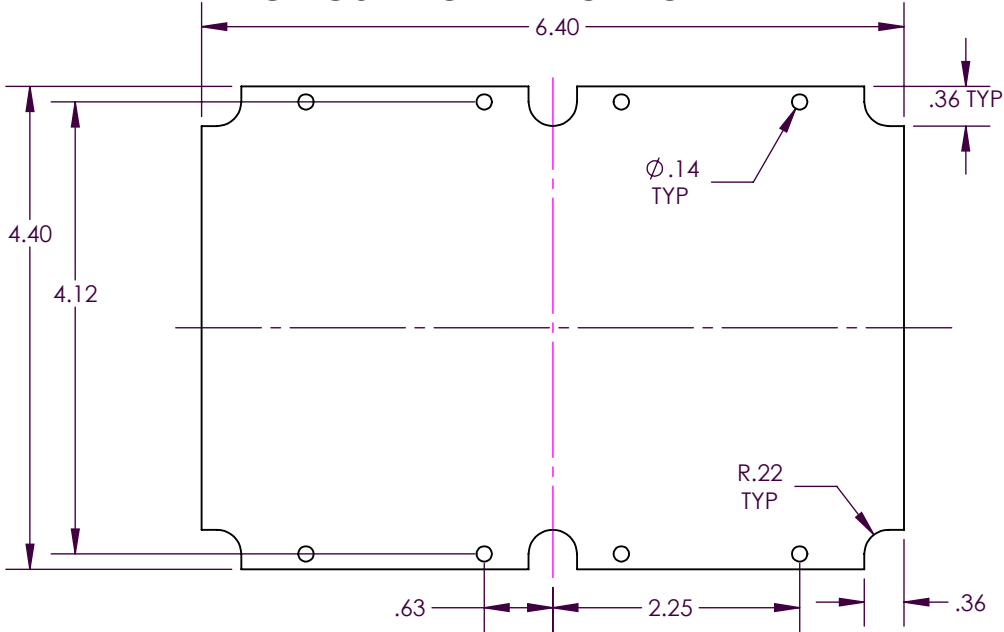

CIRCUIT BOARD FOR BOTTOM

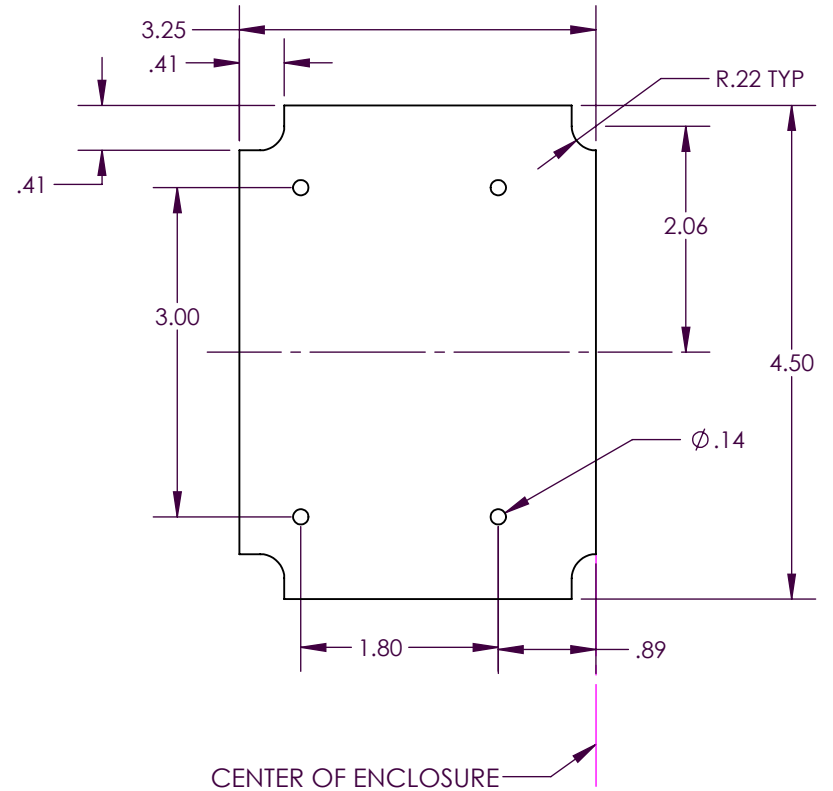

SMALL CIRCUIT BOARD FOR BOTTOM

